



PEDESTRIAN SAFETY IMPROVEMENT EVALUATION GUIDELINE FOR UNCONTROLLED CROSSINGS

Traffic Safety Engineering Division

Updated: April 2018

EXECUTIVE SUMMARY

NDOT Traffic Safety Engineering Division developed this guidance for evaluating potential pedestrian safety improvement locations. The task to determine which crossing locations will benefit from pedestrian safety improvements can be a complex process, this guidance recommends using a systemic approach based on pedestrian generators. It also emphasizes the importance for engineering judgement while allowing for design flexibility and therefore providing support for the decision-making process.

The evaluation guideline consists of three sections:

1. Data Collection

The section provides a check-off form for the individuals responsible for the field inventory. The items on the form will also be used in the following sections.

2. Countermeasures Recommendations

The section provides a decision matrix to assist in data analysis and determining possible countermeasures for the studied locations.

3. Improvement Prioritization

The section helps determine the prioritization of Pedestrian Safety Improvements projects.

The evaluation also contains an appendix with all the design details for the safety improvements methods mentioned in the document.

1. Data Collection

The following Pedestrian Safety Improvement Field Inventory Form can be used during the field reviews. Some key focus points to consider are:

- Pedestrian crash data
- Number of lanes
- Roadway width
- Median
- Stop sign/Signal/Uncontrolled
- Presence and type of lighting
- Current signage
- Traffic volumes
- Current crossing design
- Pedestrian generators
- Distance from nearest crosswalk
- Pedestrian ramp position/type
- Pedestrian land use generator categories
- Distance from intersection
- School zone influence
- Sight distance issues
- Nearest bus stop locations
- Roadway functional classification
- Sidewalk and pedestrian ramps availability
- Sidewalk and pedestrian ramps ADA compliance*
- Sidewalk connectivity to bus stops
- Presence of multi-used path or bike lane
- Speed limit
- Presence of on-street parking
- Land use

*Use the ADA GIS Feature Inventory to determine if sidewalks and ramps are ADA compliant:



<https://ndot.maps.arcgis.com/home/webmap/viewer.html?webmap=0202ae8a996a4715b9da2fe1b2e2548e>

PEDESTRIAN SAFETY IMPROVEMENT FIELD INVENTORY FORM

FILL OUT THE SECTION BELOW BEFORE FIELD INVENTORY

Location: _____	
City: _____ County: _____	
Speed Limit: _____ <input type="checkbox"/> Urban <input type="checkbox"/> Rural	AADT major*: _____ AADT major*: _____ <small>*Use the NDOT Traffic Records Information Application (TRINA) to determine AADT.</small>

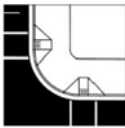
FILL OUT THE SECTION BELOW DURING/AFTER FIELD INVENTORY

Existing Traffic Control:		
<input type="checkbox"/> 2-way stop	<input type="checkbox"/> Signalized intersection	<input type="checkbox"/> Roundabout
<input type="checkbox"/> 4-way stop	<input type="checkbox"/> Non-signalized intersection	<input type="checkbox"/> Other: _____
Existing Crossing Condition:		Existing Striping:
<input type="checkbox"/> Midblock crossing <input type="checkbox"/> Intersection crossing <input type="checkbox"/> Curb extensions <input type="checkbox"/> Pedestrian refuge		<input type="checkbox"/> Marked crosswalk <input type="checkbox"/> Unmarked crosswalk Crosswalk striping condition: <input type="checkbox"/> Poor / <input type="checkbox"/> Fair / <input type="checkbox"/> Good Number of crosswalk per intersection: _____
Existing Crossing Signal & Lighting:		
<input type="checkbox"/> Pedestrian signage <input type="checkbox"/> Advance signage <input type="checkbox"/> Crosswalk lighting	<input type="checkbox"/> RRFB (Rectangular Rapid Flashing Beacon) <input type="checkbox"/> PHB (Pedestrian Hybrid Beacon) <input type="checkbox"/> Pedestrian signal	
Existing Roadway Condition (Within 1/2 Miles of the Crossing):		
<input type="checkbox"/> Bus only lane <input type="checkbox"/> Bike lane <input type="checkbox"/> Shared bus-bike lane <input type="checkbox"/> School zone <input type="checkbox"/> Bus stop <input type="checkbox"/> On street parking <input type="checkbox"/> Sight distance issue <input type="checkbox"/> Street lighting <input type="checkbox"/> Other: _____ <small>*Use the ADA GIS Feature Inventory to determine if sidewalk and ramps are Non-ADA compliant. https://ndot.maps.arcgis.com/home/webmap/viewer.html?webmap=0202ae8a996a4715b9da2fe1b2e2548e</small>	Existing sidewalk: <input type="checkbox"/> Yes / <input type="checkbox"/> No <input type="checkbox"/> One side of the roadway <input type="checkbox"/> Non-ADA compliant sidewalk* <input type="checkbox"/> Non-ADA compliant ramp* <input type="checkbox"/> Directional ramp  <input type="checkbox"/> Diagonal ramp 	<input type="checkbox"/> 2-lane undivided <input type="checkbox"/> 2-lane with center left turn lane <input type="checkbox"/> 2-lane with raised median <input type="checkbox"/> 4-lane undivided <input type="checkbox"/> 4-lane with center left turn lane <input type="checkbox"/> 4-lane with raised median <input type="checkbox"/> 6-lane with center left turn lane <input type="checkbox"/> 6-lane with raised median Roadway width: _____

2. Pedestrian Safety Countermeasures Recommendations

The following Uncontrolled Crosswalk Decision Matrix can be used to assist in data analysis and determining possible countermeasures. The matrix utilizes Vehicle ADT, Speed Limits (mph), and Number of Travel Lanes to help suggest possible countermeasures when implementing pedestrian safety.

The additional guidelines below will also need to be followed:

- When installing RRFBs, an overhead RRFB should be used if there are two or more lanes in each direction and a speed limit of 35 mph or higher.
- Enhanced crosswalk lighting should be added to all potential pedestrian safety improvement locations. While the design standard is focused for midblock locations, engineering judgment must be used when determining the best possible solution while designing intersection crosswalk lighting. NDOT has determined street light luminaire should be located so that it provides 20 vertical lux at the crosswalk. The specification states that LED luminaires should be utilizing 16,500 lumens or greater.
- Use Advanced RRFB's under the following conditions:
 - Limited sight distance to the crosswalk.
 - Three or more lanes in each direction on an arterial roadway with a 45 mph or greater posted speed limit.
 - Two lanes in each direction with an observed speed limit of 35 mph or greater - consider an Advanced RRFB.
 - Where traffic signals are one half mile to one mile apart.
- Curb extensions can be considered if there is on-street parking and there is a need to improve pedestrian sight distances.

UNCONTROLLED CROSSWALK DECISION MATRIX

(Treatment to be applied only if evaluations of conditions and engineering judgement indicates that the treatment will provide a significant safety benefit)

Roadway Type (Number of Travel Lanes and Median Type)	Vehicle ADT < 9,000			Vehicle ADT > 9,000 to 12,000			Vehicle ADT > 12,000 to 15,000			Vehicle ADT > 15,000		
	Posted Speed Limit											
	≤30 mph	35 mph	≥40 mph	≤30 mph	35 mph	≥40 mph	≤30 mph	35 mph	≥40 mph	≤30 mph	35 mph	≥40 mph
Two lanes	C/1	C/1	P/2	C/1	C/1	P/2	P/2	P/3	P/3	P/2	P/3	P/3
Three lanes	C/1	C/1	P/2	C/1	P/2	P/2	P/2	P/2	P/3	P/2	P/3	P/3
Multilane (four or more lanes with raised median)	C/1	C/2	P/2	C/2	P/2	P/3	P/2	P/2	P/3	P/3	P/3	P/3
Multilane (four or more lanes without raised median)	C/1	P/2	P/3	P/2	P/2	P/3	P/3	P/3	P/3	P/3	P/3	P/3

C - Candidate sites for marked crosswalks*. An engineering study is required to determine whether a marked crosswalk will provide a significant safety benefit. A site review may be sufficient at some locations, while a more in-depth study of vehicle speeds, sight distance, vehicle mix, and other factors may be needed at other sites. See crossing treatment type number 1 and 2.

P - Possible increase in pedestrian crash risk if crosswalks alone are added without other pedestrian facility enhancements. If the evaluation determines that a crosswalk would provide a significant safety benefit, then crosswalk locations should be enhanced with other pedestrian crossing improvements such as those shown in Crossing Treatment Types Number 2 and 3.

Minimum crosswalk treatments at uncontrolled locations should follow the requirements of the most current version of Manual on Uniform Traffic Control Devices (MUTCD).

Crossing Treatment Types:

1 - High visibility crosswalk striping, pedestrian refuge island, advanced yield lines, enhanced crosswalk lighting.

2 - Pedestrian refuge island, overhead pedestrian crossing signs, pedestrian activated Rectangular Rapid Flashing Beacon (RRFB) side and/or overhead mounted, pedestrian fencing, yield lines, parking removal between crosswalk and yield lines and enhanced crosswalk lighting. Consider using advanced pedestrian activated RRFBs.

3 - Pedestrian Hybrid Beacon (PHB), pedestrian activated Rectangular Rapid Flashing Beacon (RRFB) side and/or overhead mounted with advanced pedestrian activated RRFBs, pedestrian fencing, pedestrian signal, two-stage crossing, stop or yield lines, parking removal between crosswalk and yield lines, and enhanced crosswalk lighting should be considered. Installation of traffic signals cannot be considered unless traffic conditions meet warrant criteria specified in the MUTCD.

***NRS-484A.065 “Crosswalk Defined”**

Crosswalk means:

1. That part of a highway at an intersection within the connections of the lateral lines of the sidewalks on opposite sides of the highway measured from the curbs or, in the absence of curbs, from the edges of the traveled portions of highways; or
2. Any portion of a highway at an intersection or elsewhere distinctly indicated for pedestrian crossing by lines or other marking on the surface.

The following is a description of Pedestrian Safety Countermeasures that are found in the Uncontrolled Crosswalk Decision Matrix. The standard design details for the items below can be found in the appendix of this document.

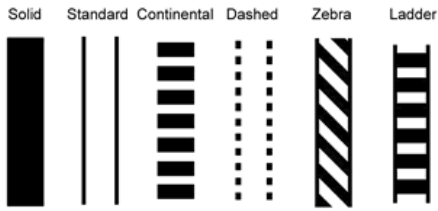

High Visibility Crosswalk Striping

The standard treatment for marked crosswalks at locations consists of retro-reflective pavement markings that delineate the pedestrian walking area.

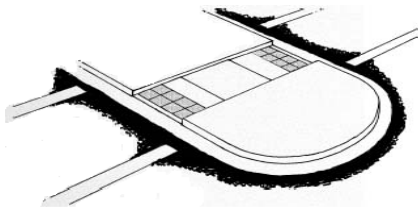

Pedestrian Refuge Island

This area between opposing lanes of traffic allows pedestrians to cross one direction of traffic at a time on wide streets. Median/Pedestrian Refuge Islands are one of the FHWA proven safety countermeasures.



Danish Offset

Danish Offset is the use of an offset at the middle of a multilane crossing to ensure pedestrians are facing the next half of traffic being crossed. In addition, it also provides a median refuge to pedestrians.

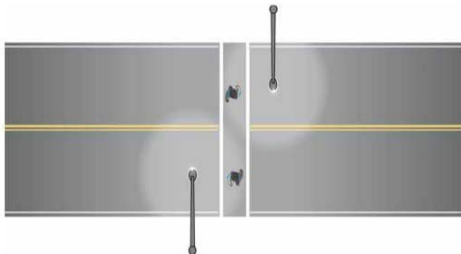

Enhanced Crosswalk Lighting

FHWA developed an information report on crosswalk lighting (FHWA-HRT-08-053: Informational Report on Lighting Design for Midblock Crosswalks) which provides information on lighting parameters and design criteria. NDOT utilizes an enhanced street light concept for uncontrolled crosswalk locations, which requires the lighting to have a 25-ft. maximum offset from the crosswalk and 16500 lumen fixtures.



Rectangular Rapid Flashing Beacon (RRFB)

Small rectangular flashing lights are positioned with pedestrian crossing signs and are activated by pedestrians manually with a push button. Once activated, an irregular flashing pattern will flash for a predetermined amount of time to allow the pedestrian time to cross the roadway after vehicles have stopped.

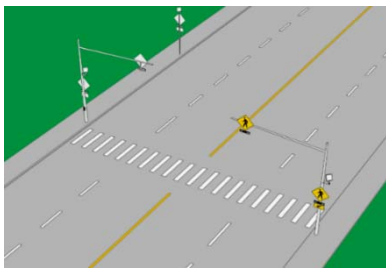

Overhead Rectangular Rapid Flashing Beacon (RRFB)

Utilized on roadways with more than one lane of travel and higher speeds to increase driver visibility.

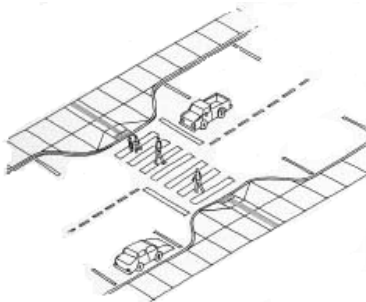

Curb Extensions

Curb extensions are used to extend the sidewalk into the street to reduce the crossing distance for pedestrians. They also allow the pedestrian to be seen by approaching vehicles when other vehicles are parked and visually blocking the pedestrian from the roadway.

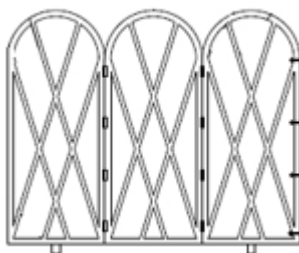

Pedestrian Fencing

Pedestrian fencing may be used within the median to restrict pedestrians from crossing the roadway, reducing conflict between motorized vehicles and pedestrians.

		
1. Dark until activated	2. Flashing yellow light for 3–6 s	3. Steady yellow light for 3–6 s
		
4. Steady red light during pedestrian interval	5. Alternating flashing red lights during pedestrian clearance interval	

Pedestrian Hybrid Beacon (PHB)

A pedestrian activated warning device located on a mast arm over a midblock crossing location. In general, they should be used if gaps in traffic are not adequate to permit pedestrians to cross. Chapter 4F of the MUTCD contains information on when a PHB may be installed. The Pedestrian Hybrid Beacon is one of the FHWA proven safety countermeasures.

3. Pedestrian Safety Improvement Prioritization

Following the data collection and analysis phase, the studied locations need to be evaluated to determine the prioritization of Pedestrian Safety Improvements compared to other locations. NDOT Traffic Safety Engineering developed a Pedestrian Safety Weighted Values Form to assign a weighted value to studied locations. The Pedestrian Safety Weighted Values are based on demographic, posted speed limits, roadway widths, and pedestrian generators.

The pedestrian generators are categorized as High/Medium/Low based on the number of pedestrians they generate. In each case, the distance from the generator to the studied location will also need to be taken into consideration. NDOT Traffic Safety Engineering observed that the locations where most pedestrian crashes occur may not show high pedestrian counts, but at the locations where drivers are not expecting pedestrians. Therefore, such locations are being weighted at a higher value. If there are multiple generators within 1/8 mile, assign the value based on the distance most remote from the generator.

When the form is complete, sum up all the numbers to get the Pedestrian Safety Weighted Value for the studied location. This number will be used to compare to other studied areas to determine whether the studied location needs to be prioritized for pedestrian safety improvements.

PEDESTRIAN SAFETY WEIGHTED VALUES FORM					
Land Use Category	Sub-Category	Examples/Notes	Weight 1/8 Mile	Weight 1/4 Mile	Weight 1/2 Mile
High Generator	University or College		15	10	5
	Major Generator	Convention Center, Casino	15	10	5
	Multi-family Living	Condominiums, Apartments, Mobile Home Park	10	5	3
Medium Generator	School		5	3	1
	Major Retail	Grocery Store, Convenient Store, Banks, etc.	5	3	1
	Bars		5	3	1
	Hotels	Motels	5	3	1
	Food Services	Restaurants, Fast Food, etc.	5	3	1
	Hospital	Clinics	5	3	1
	Bus Stop		5	3	1
	Senior Living	Hospice Care	5	3	1
	Community Services	Community Centers, Libraries, Post Offices, Social Services, Churches, etc.	5	3	1
Low Generator	Minor Retail	General Retail, Offices, etc.	3	1	0
	Park		3	1	0
	Trials	Bike Path, Multi-Use	3	1	0
Street Classification	Local			1	
	Collector			3	
	Minor Arterial			4	
	Principal Arterial			5	
Speed Limit	≤30			1	
	35+			3	
	40+			4	
	≥45			5	
Sidewalk Status	Missing			20	
	Narrow	< 4 feet		10	
	Standard	4 - 6 feet		0	
	Wide	> 6 feet		-10	
Parking	Yes On-street parking			0	
	No On-street parking			5	
Curb	Yes			0	
	No			2	
Road Width	0 - 24 feet			0	
	24 - 36 feet			2	
	36 - 48 feet			4	
	48 - 60 feet			6	
	61+ feet			10	
Distance Between Major Intersections	0 - 500 feet			0	
	500 - 1000 feet			2	
	1000 - 2000 feet			4	
	2000+ feet			5	
Stop Control	Roundabout			-4	
	Signal			-3	
	4-way Stop Sign			-2	
	2-way Stop Sign			-1	

REFERENCES

City of Boulder Department of Transportation. (2011). *Pedestrian Crossing Treatment Installation Guidelines*. Boulder, CO: City of Boulder Transportation Division.

Federal Highway Administration (2003, November). *A Review of Pedestrian Safety Research in the United States and Abroad, Part 3*. FHWA:
<https://www.fhwa.dot.gov/publications/research/safety/pedbike/03042/part3.cfm>

Federal Highway Administration. (2009). *Manual on Uniform Traffic Control Devices for Streets and Highways (MUTCD)*. FHWA:
http://mutcd.fhwa.dot.gov/hdm/2009r1r2/hdm_index.htm

Federal Highway Administration. (2015, September). *Pedestrian Safety Guide and Countermeasure Selection System*. PEDSAFE: <http://www.pedbikesafe.org/PEDSAFE/>

Federal Highway Administration. (2012, January). *Guidance Memorandum on Promoting the Implementation of Proven Safety Countermeasures*. FHWA:
<http://safety.fhwa.dot.gov/provencountermeasures/>

Federal Highway Administration. (1999). *Designing Sidewalks and Trails for Access, Part I*. FHWA:
http://www.fhwa.dot.gov/environment/bicycle_pedestrian/publications/sidewalks/sidewalks.pdf

Federal Highway Administration. (2001). *Designing Sidewalks and Trails for Access, Part II*. FHWA:
http://www.fhwa.dot.gov/environment/bicycle_pedestrian/publications/sidewalk2/pdf.cfm

Fitzpatrick, K., & Park, E. (2010). *Safety Effectiveness of the HAWK Pedestrian Crossing Treatment*. Washington, D.C.: Federal Highway Administration.

Fitzpatrick, K., Turner, S., Brewer, M., Carlson, P., Ullman, B., Trout, N., ... Lord, D. (2006). *TCRP Report 112/NCHRP Report 562: Improving Pedestrian Safety at Unsignalized Intersections*. Transportation Research Board:
http://onlinepubs.trb.org/onlinepubs/nchrp/nchrp_rpt_562.pdf

Frederick, M., Rice, E. (2008). *Rectangular Rapid Flash Beacon (RRFB)*. Washington, DC: Federal Highway Administration.

Gibbons, R., B., Edwards, C., Williams, B., & Anderson, C. (2008, April). *Information Report on Lighting Design for Midblock Crosswalks*. McLean, VA: Federal Highway Administration.

NCDOT. (2015, July). *North Carolina Pedestrian Crossing Guidance*. NCDOT.gov:
https://connect.ncdot.gov/resources/safety/Tepl/TEPPLAllDocumentsLibrary/Pedestrian_Crossing_Guidance.pdf

VDOT. (2012). *Guidelines for the Installation of Marked Crosswalks*. VirginiaDOT.org:
http://www.virginiadot.org/business/resources/Marked_Crosswalks_Final_Guidelines_2012-14-05.pdf

Zegeer, C. V., Stewart, J. R., Haung, H. H., Lagerwey, P. A., Feaganes, J., & Campbell, B. J. (2005, November). *Safety Effects of Marked Versus Unmarked Crosswalks at Uncontrolled Locations*. FHWA: <http://www.fhwa.dot.gov/publications/research/safety/04100/04100.pdf>

T-36-1

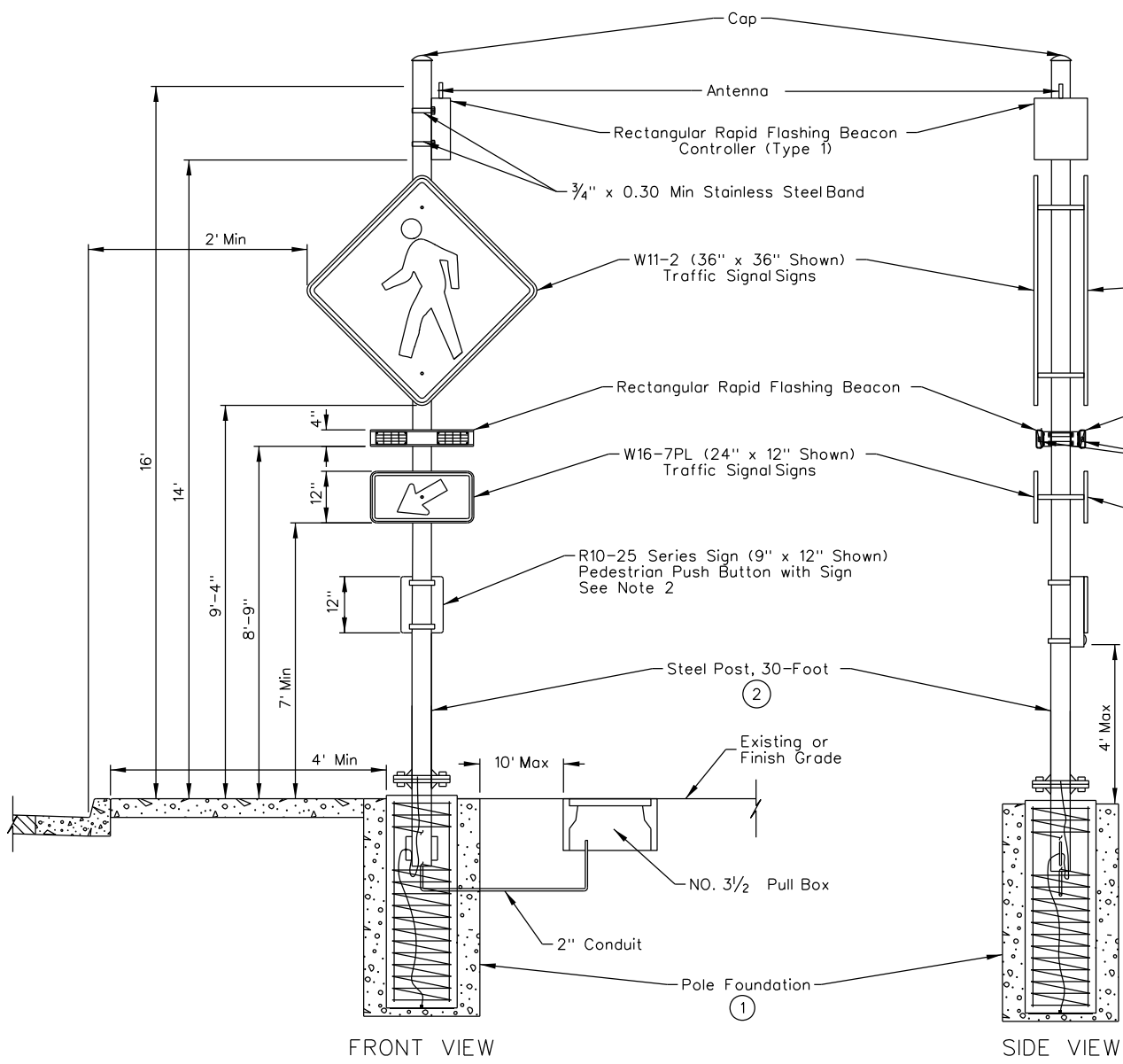

NOTES:

- 1. RRFB must include pedestrian indication side flasher that faces crosswalk.
- 2. Install push button on side of pole facing pedestrian ramp.

- ① See Sheet T-30.5.2 for Foundation
- ② See Sheet T-33.4.1 and T-33.4.2 for Steel Post, 30-Foot

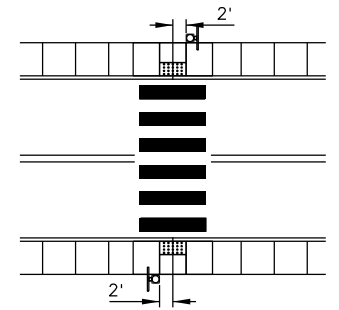

See Sheet T-31.6.5 for Midblock Crosswalk Lighting Detail. Align Post Such that it is Tangent to the Back of the Sidewalk and Tangent to the Detectable Warning Joint.

FRONT VIEW

SIDE VIEW

AC POWER

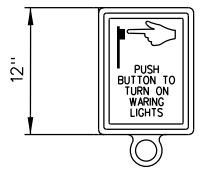

FRONT FACE OF PEDESTRIAN PUSH BUTTON

STATE OF NEVADA DEPARTMENT OF TRANSPORTATION		
TYPE 1 (RRFB) RECTANGULAR RAPID FLASHING BEACON		
T-31.6.1	(623)	Signed Original On File
ADOPTED	REVISED	CHIEF TRAFFIC OPS ENGR.
	10/15	

T-37

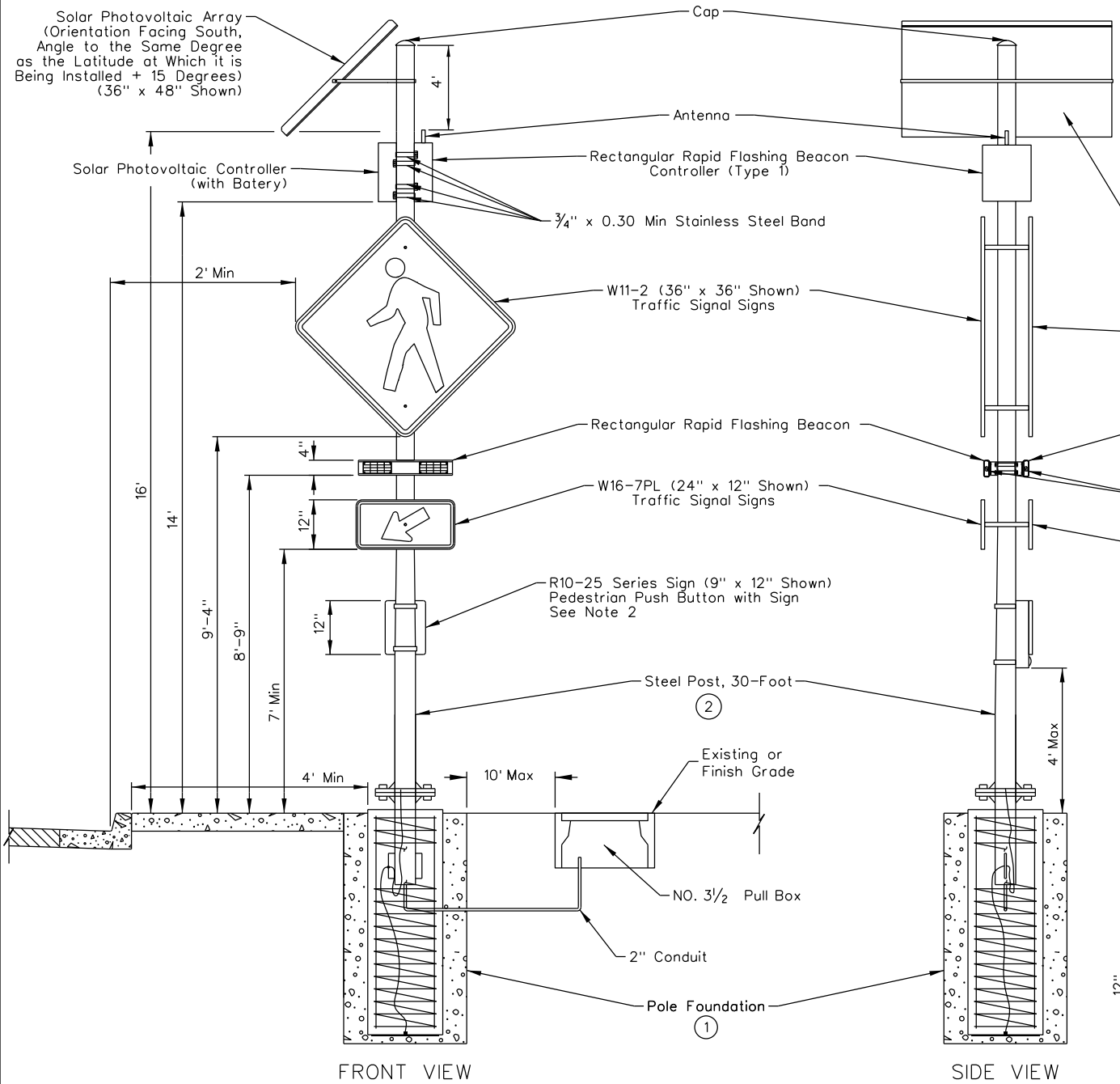

NOTES:

- 1. RRFB must include pedestrian indication side flasher that faces crosswalk.
 - 2. Install push button on side of pole facing pedestrian ramp.
- ① See Sheet T-30.5.2 for Foundation
- ② See Sheet T-33.4.1 and T-33.4.2 for Steel Post, 30-Foot

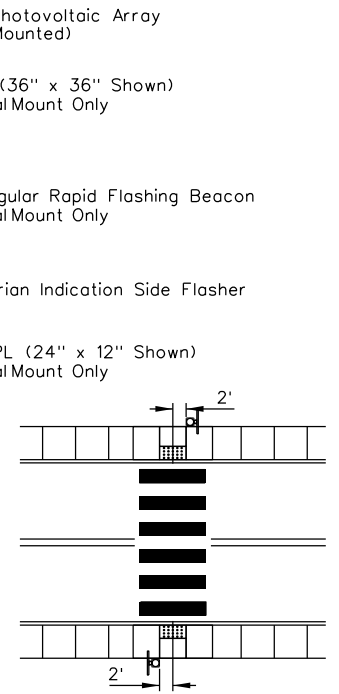

See Sheet T-31.6.5 for Midblock Crosswalk Lighting Detail. Align Post Such That it is Tangent to the Back of the Sidewalk and Tangent to the Detectable Warning Joint.

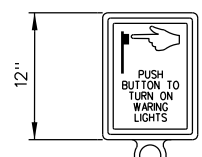

FRONT FACE OF PEDESTRIAN PUSH BUTTON

STATE OF NEVADA DEPARTMENT OF TRANSPORTATION		
TYPE 1S (RRFB) RECTANGULAR RAPID FLASHING BEACON		
T-31.6.2	(623)	Signed Original On File
ADOPTED	REVISED	CHIEF TRAFFIC OPS ENGR.
	10/15	

T-37

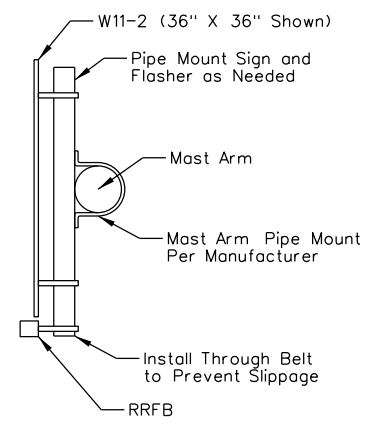
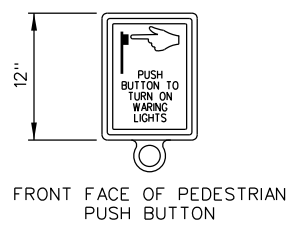
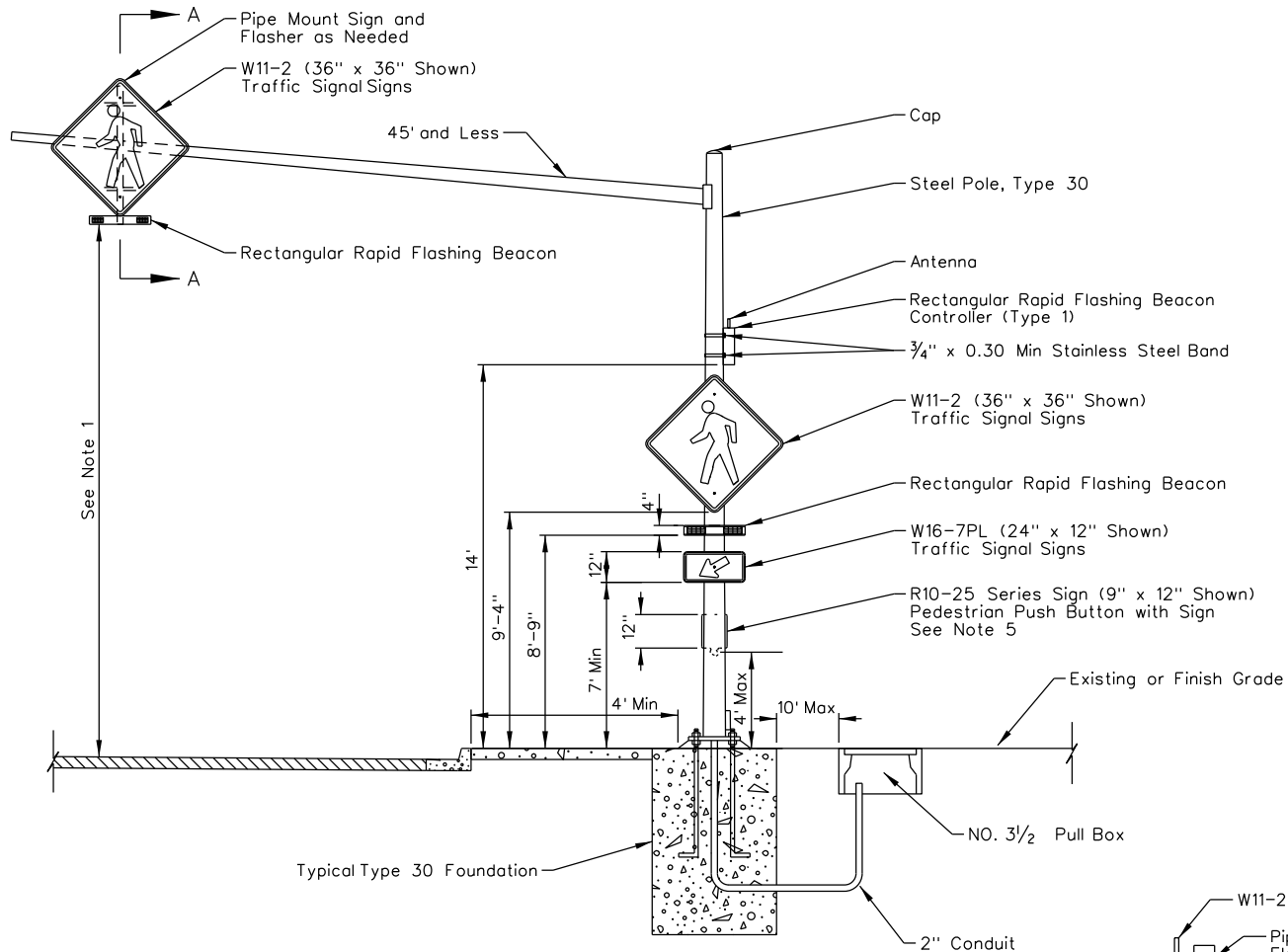

SECTION A-A

NOTES:

1. Locate RRFB vertically on mast arm no lower than 18 feet 6 inches from the roadway surface. Distance is measured from the bottom edge of the RRFB to the actual travel lane surface. Locate RRFB and sign horizontally on mast arm centered over the travel lanes.
2. RRFB must include a pedestrian indication side flasher that faces crosswalk.
3. See sheet T-31.5.2 for connection and base plate details.
4. See sheet T-30.5.2 for foundation details.
5. Install push button on side of pole facing pedestrian ramp.

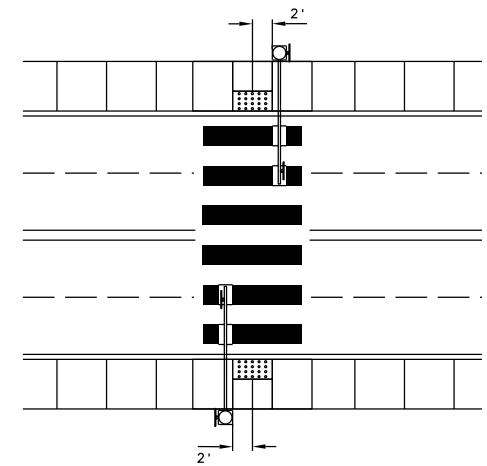

See Sheet T-31.6.5 for Midblock Crosswalk Lighting Detail. Align Pole Such that it is Tangent to the Back of the Sidewalk and Tangent to the Detectable Warning Joint.

STATE OF NEVADA DEPARTMENT OF TRANSPORTATION		
TYPE 2 (RRFB) RECTANGULAR RAPID FLASHING BEACON		
T-31.6.3	(623)	Signed Original On File
ADOPTED	REVISED	CHIEF TRAFFIC OPS ENGR.
	10/15	

8C-I
T-38

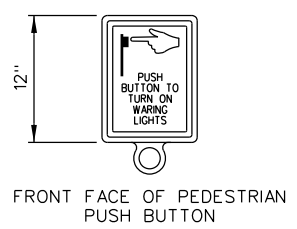
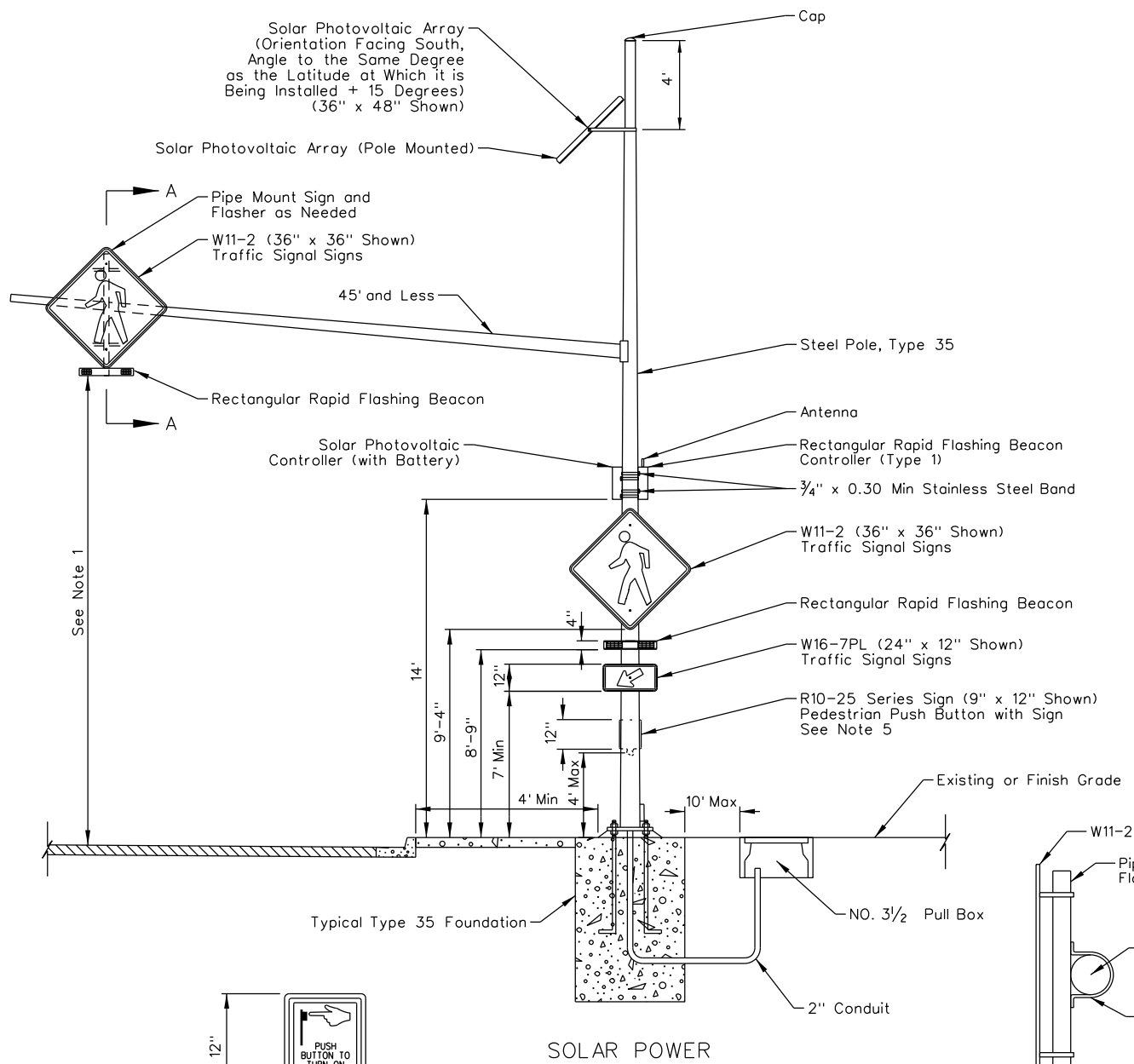

SOLAR POWER

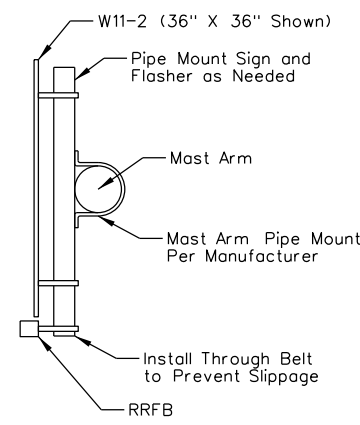

SECTION A-A

NOTES:

1. Locate RRFB vertically on mast arm no lower than 18 feet 6 inches from the roadway surface. Distance is measured from the bottom edge of the RRFB to the actual travel lane surface. Locate RRFB and sign horizontally on mast arm centered over the travel lanes.
2. RRFB must include a pedestrian indication side flasher that faces crosswalk.
3. See sheet T-31.5.2 for connection and base plate details.
4. See sheet T-30.5.2 for foundation details.
5. Install push button on side of pole facing pedestrian ramp.

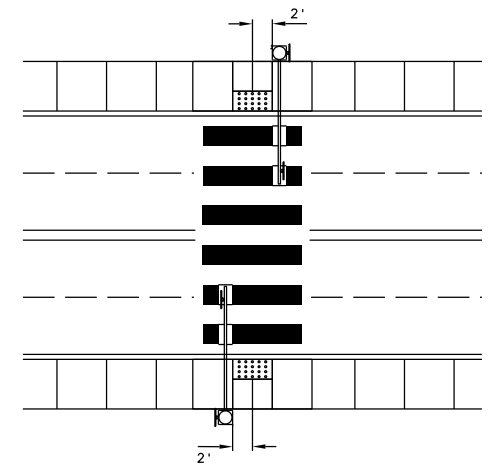

See Sheet T-31.6.5 for Midblock Crosswalk Lighting Detail. Align Pole Such that it is Tangent to the Back of the Sidewalk and Tangent to the Detectable Warning Joint.

STATE OF NEVADA DEPARTMENT OF TRANSPORTATION		
TYPE 2S (RRFB) RECTANGULAR RAPID FLASHING BEACON		
T-31.6.4	(623)	Signed Original On File
ADOPTED 10/15	REVISED	CHIEF TRAFFIC OPS ENGR.

NOTES:

1. See sheet T-32.1.1 for Type 7 pole details.
2. See sheet T-38.1.3 for crosswalk pavement markings.

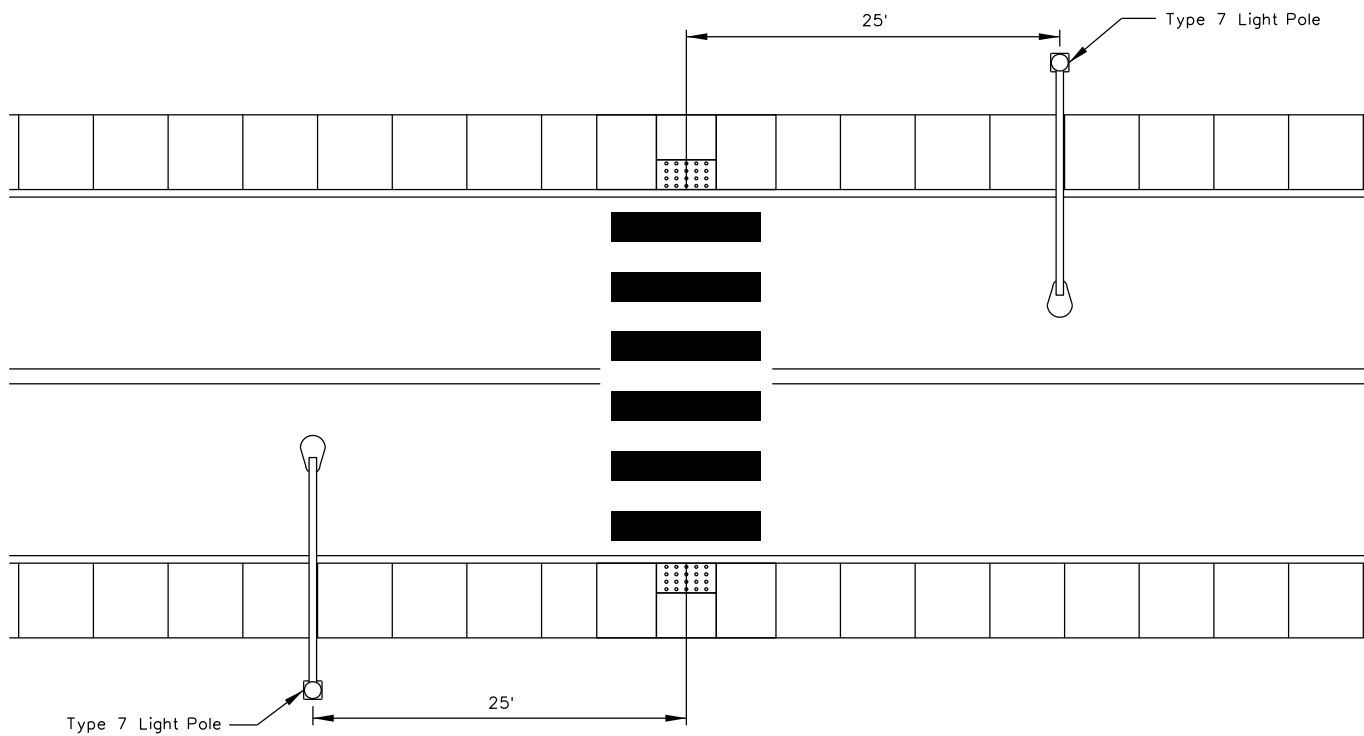

T-40

STATE OF NEVADA
DEPARTMENT OF TRANSPORTATION

MIDBLOCK
CROSSWALK LIGHTING

T-31.6.5	(623)	Signed Original On File
ADOPTED 10/15	REVISED	CHIEF TRAFFIC OPS ENGR.

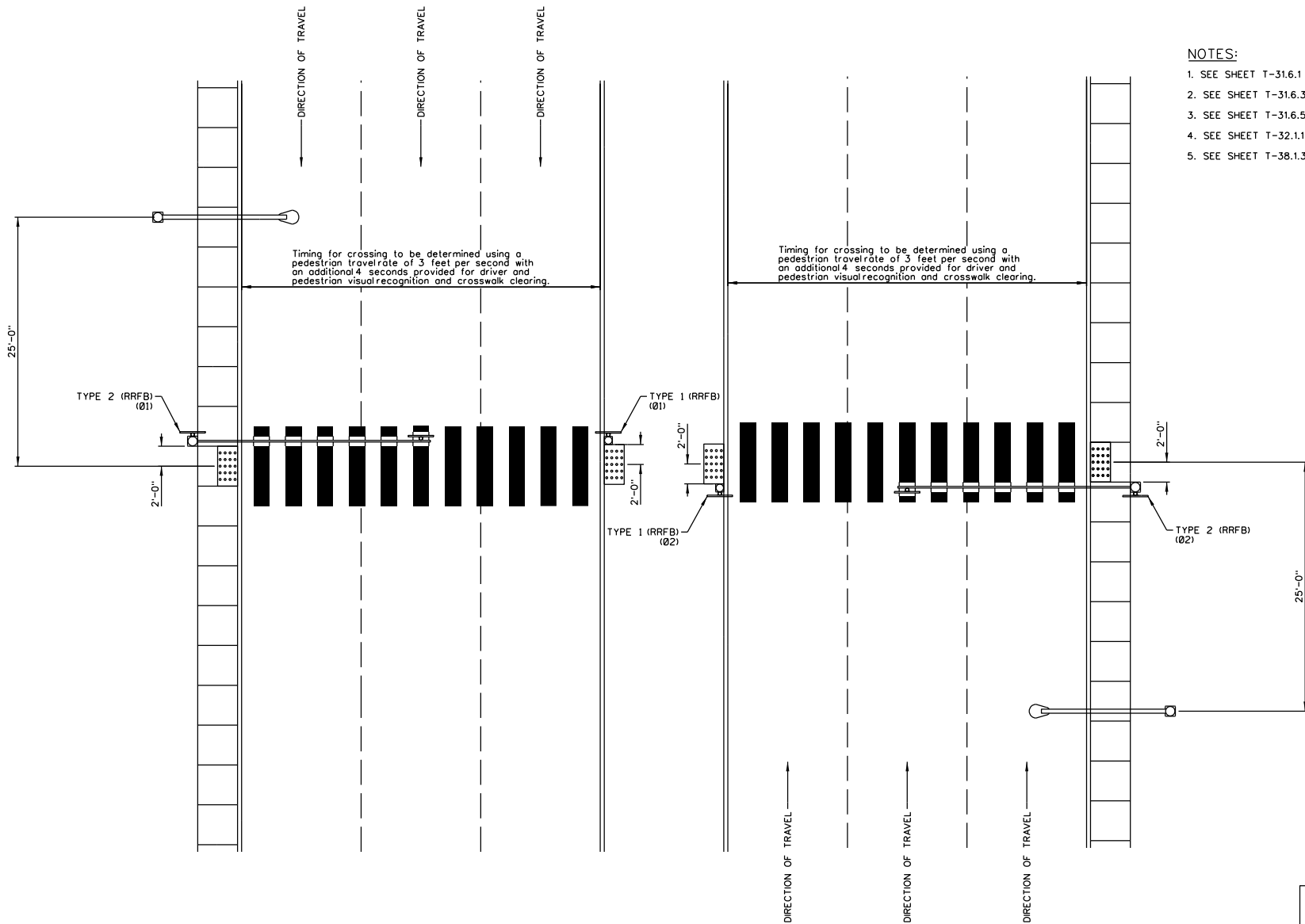

NOTES:

1. SEE SHEET T-31.6.1 (2017) AND T-31.6.2 (2017) FOR TYPE 1 (RRFB) DETAILS.
2. SEE SHEET T-31.6.3 (2017) AND T-31.6.4 (2017) FOR TYPE 2 (RRFB) DETAILS.
3. SEE SHEET T-31.6.5 (2017) FOR MIBLOCK CROSSWALK LIGHTING DETAILS.
4. SEE SHEET T-32.1.1 (2017) FOR TYPE 7 POLE DETAILS.
5. SEE SHEET T-38.1.3 (2017) FOR CROSSWALK PAVEMENT MARKINGS.

STATE OF NEVADA
DEPARTMENT OF TRANSPORTATION

ITS DETAIL
TWO-PHASE
RECTANGULAR RAPID
FLASHING BEACON
LAYOUT

R-62

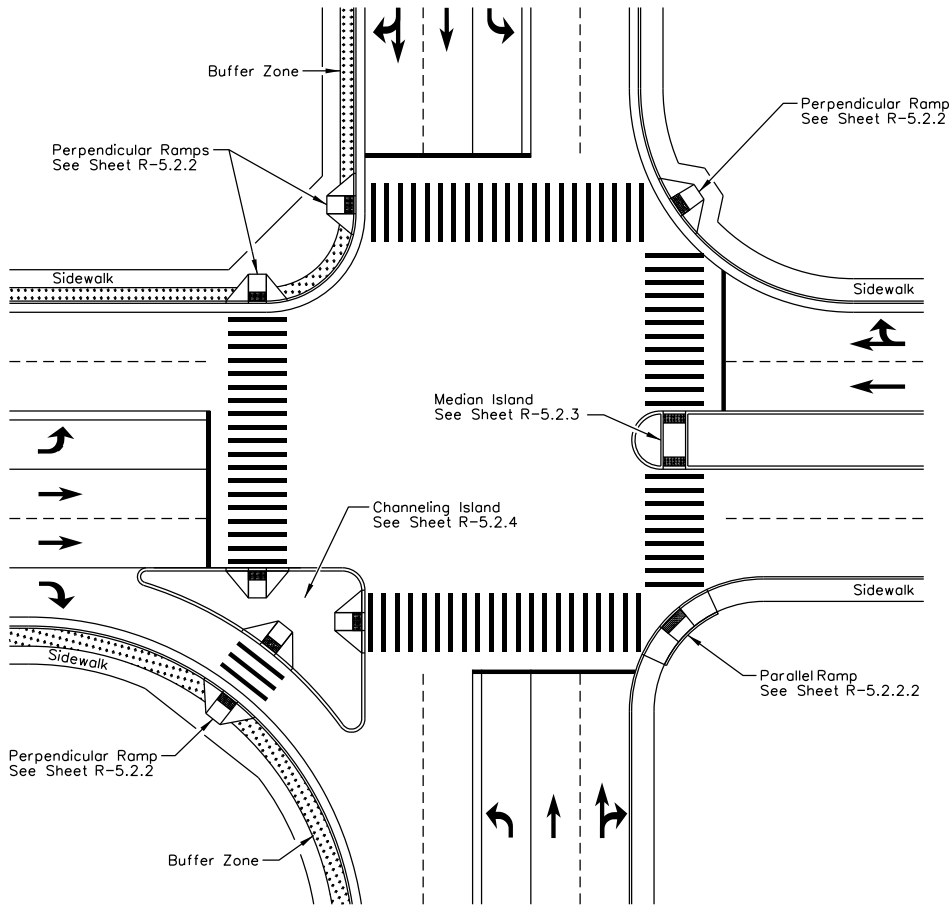

PLAN VIEW

TABLE 1 - TRANSITIONS LENGTHS FOR 8.3% SIDE SLOPES

GRADE % B TO A	A MIN.	B MIN.
> -4.00	4' - 6"	15'
-4 TO -3.01	4' - 6"	12'
-3 TO -2.01	5'	9' - 6"
-2 TO -1.01	5' - 6"	8'
-1 TO 1	7'	7'
1.01 TO 2	8'	5' - 6"
2.01 TO 3	9' - 6"	5'
3.01 TO 4	12'	4' - 6"
> 4.00	15'	4' - 6"

TABLE 2 - TRANSITIONS LENGTHS FOR 10% SIDE SLOPES

GRADE % B TO A	A MIN.	B MIN.
-6 TO -5.01	4'	12' - 6"
-5 TO -4.01	4'	10'
-4 TO -3.01	4'	8' - 6"
-3 TO -2.01	4'	7' - 6"
-2 TO -1.01	4' - 6"	6' - 6"
-1 TO 1	5' - 6"	5' - 6"
1.01 TO 2	6' - 6"	4' - 6"
2.01 TO 3	7' - 6"	4'
3.01 TO 4	8' - 6"	4'
4.01 TO 5	10'	4'
5.01 TO 6	12' - 6"	4'

Tables apply to curb with 6" curb face.
If curb has greater than a 6" curb face a special detail is required.

NOTES:

1. Extend detectable warning the full width of the curb ramp (exclusive of flared sides).
2. Grates for storm drains shall not be placed in the crosswalk or in front of the curb ramp.
3. Transitions from ramps to gutters or roadway surface shall be flush and free of abrupt changes.
4. Plantmix bituminous open-graded surface shall be flush with the edge of the gutter pan.
5. Rough broom texture on curb ramps and wings. Texture shall provide a visual contrast to the sidewalk.
6. For crosswalk markings see sheet T-38.1.3.
7. All ramps shall be 8.3% or flatter, 15 foot maximum length, Engineer should be notified for assessment if the curb ramp exceeds 15 foot in length due to the longitudinal roadway grade.
8. All slope rates are relative to level.
9. Concrete shall be class A or AA.
10. Raise gutter flowline 2 inch maximum, when required to prevent ponding at the ramp and maintain positive drainage.
11. If there are R/W restrictions the sidewalk width can be reduced to no less than 4 foot with approval of the Assistant Chief Road Design Engineer. If the sidewalk width is less than 5 foot then 5 foot by 5 foot passing zones are required at 200 foot intervals.
12. No direct payment for neat line saw cut. An additional 1 foot of pavement shall be required. If electing to remove an additional 1 foot match existing structural section with patch. No adjustment to the plan quantities for removal and patching.
13. Shared use path ramps, excluding the flared sides, shall be as wide as the shared use path.

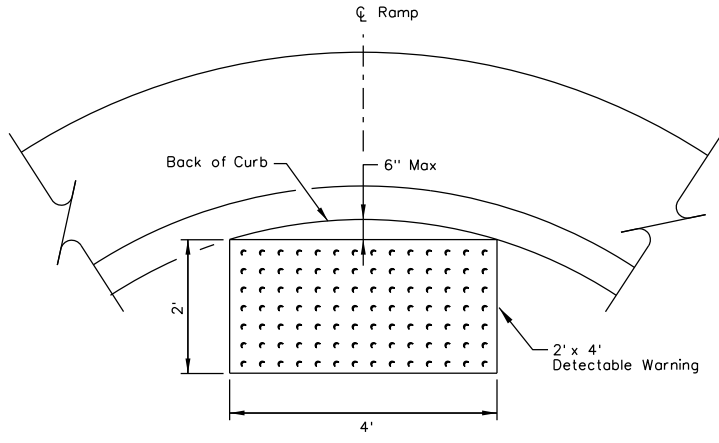

DETECTABLE WARNING

STATE OF NEVADA DEPARTMENT OF TRANSPORTATION		
CURB RAMPS AND DETECTABLE WARNING		
R-5.2.1	(613)	Signed Original On File
ADOPTED 7/96	REVISED 10/15	CHIEF ROAD DESIGN ENGR.

R-63

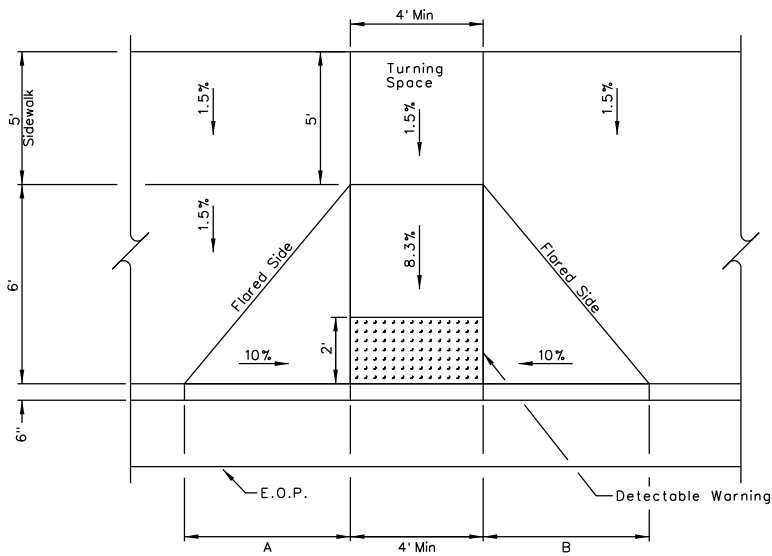

PLAN VIEW

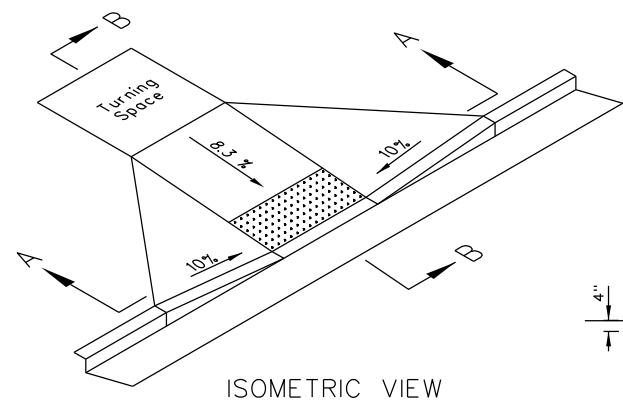

ISOMETRIC VIEW

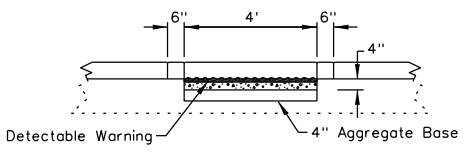

SECTION C-C

NOTES:

1. If buffer zone is wider than 6 feet, the side flares may be omitted and a returned curb option may be used.
2. For additional notes see sheet R-5.2.1

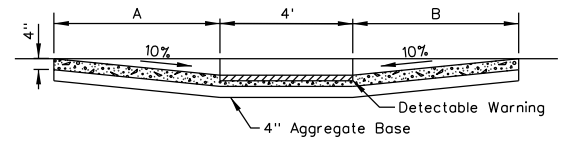

SECTION A-A

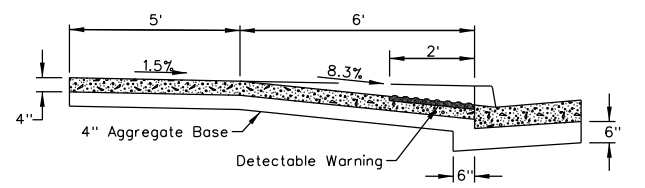

SECTION B-B

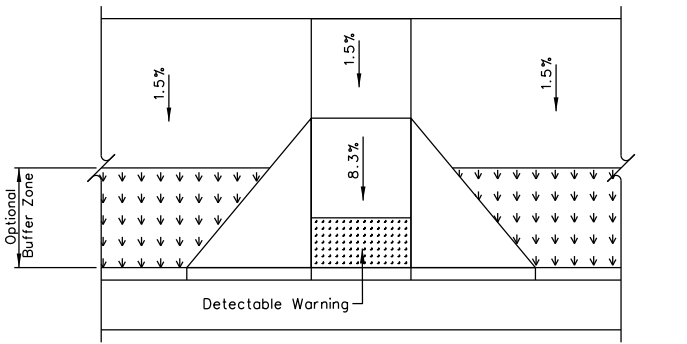

CURB RAMP WITH SIDE FLARES

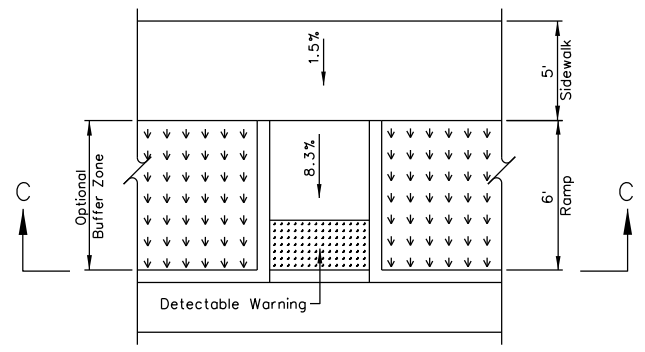

CURB RAMP WITH RETURN CURB

STATE OF NEVADA DEPARTMENT OF TRANSPORTATION		
PERPENDICULAR CURB RAMP		
R-5.2.2	(613)	Signed Original On File
ADOPTED 7/96	REVISED 10/15	CHIEF ROAD DESIGN ENGR.

NOTES:
 1. See sheet R-5.2.1 for notes.

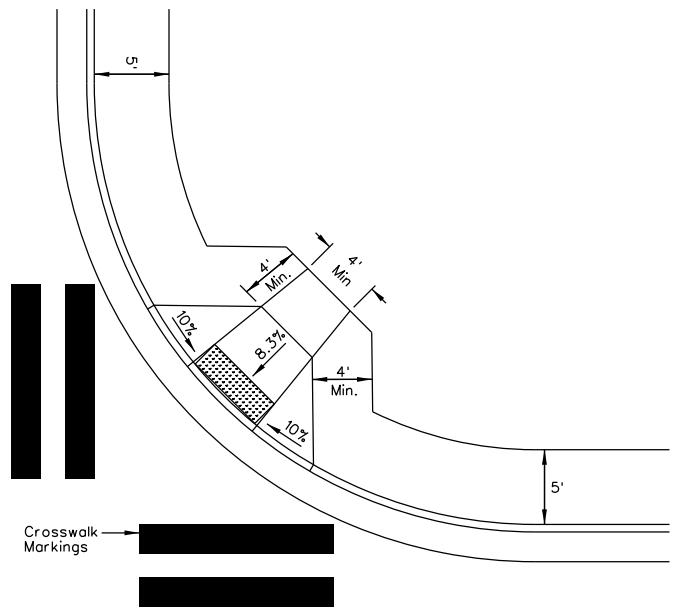

CURB RAMP WITHIN RADIUS

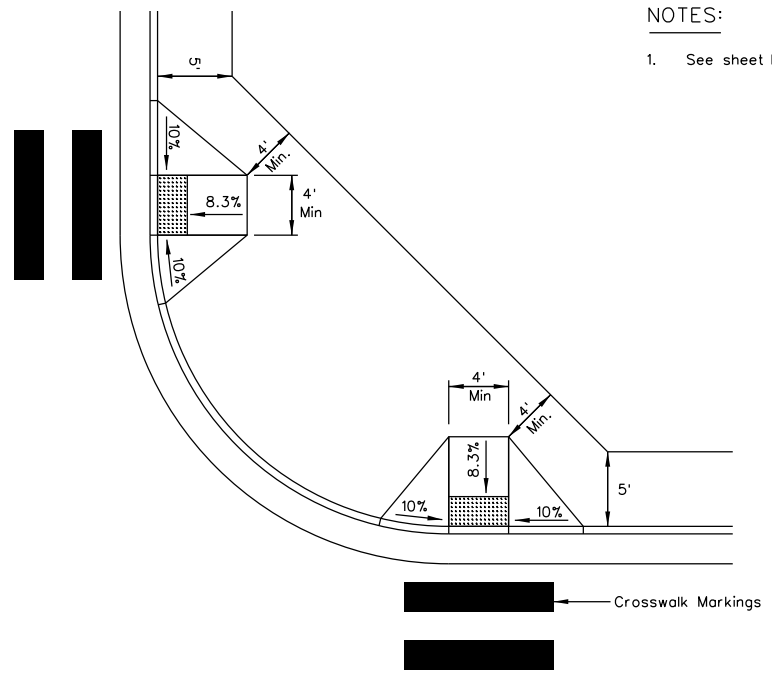

CURB RAMP OUTSIDE RADIUS

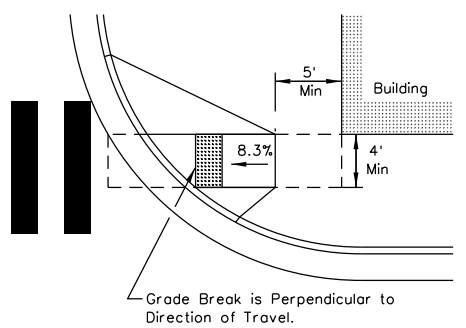

CONSTRAINED TURNING SPACE

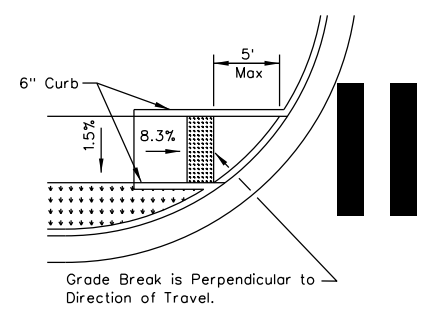

DETECTABLE WARNING PLACEMENT

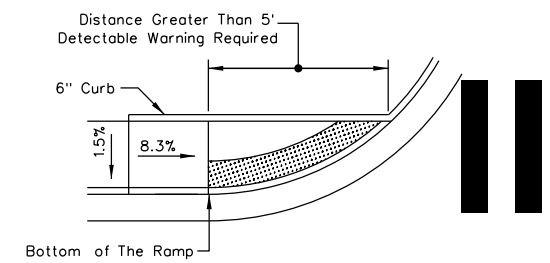

STATE OF NEVADA DEPARTMENT OF TRANSPORTATION		
PERPENDICULAR CURB RAMP		
R-5.2.2.1	(613)	Signed Original On File
ADOPTED 7/96	REVISED 10/15	CHIEF ROAD DESIGN ENGR.

R-65

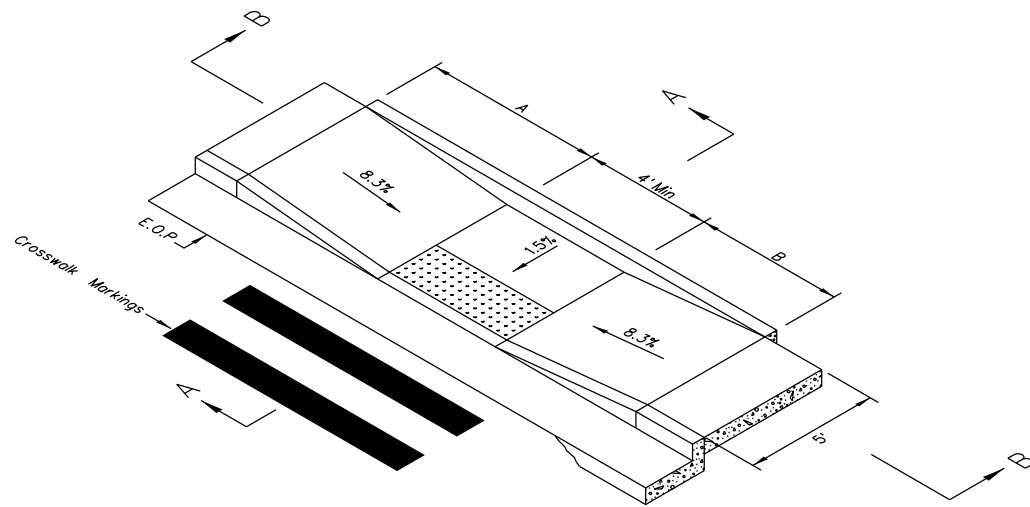

PARALLEL CURB RAMP DETAIL

NOTES:

1. See sheet R-5.2.1 for notes.

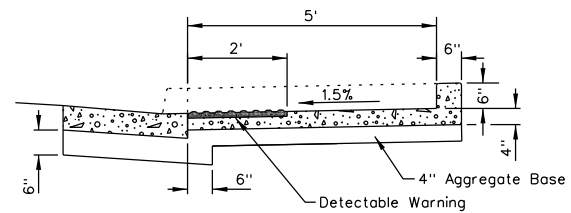

SECTION A-A
(With Back Curb)

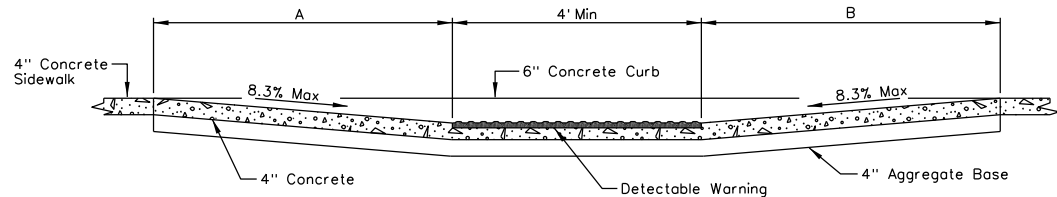

SECTION B-B

STATE OF NEVADA DEPARTMENT OF TRANSPORTATION		
PARALLEL CURB RAMP		
R-5.2.2.2	(613)	Signed Original On File
ADOPTED 7/96	REVISED 10/15	CHIEF ROAD DESIGN ENGR.

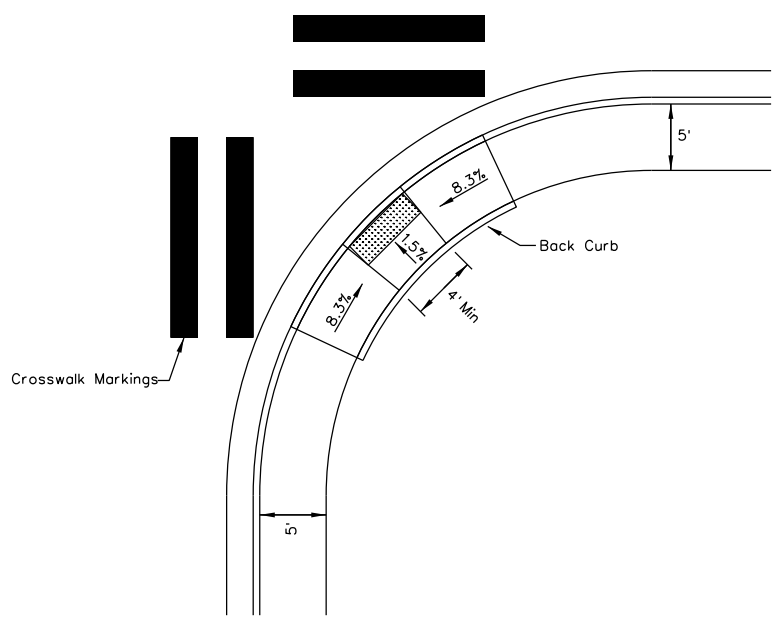

CURB RAMP WITHIN RADIUS

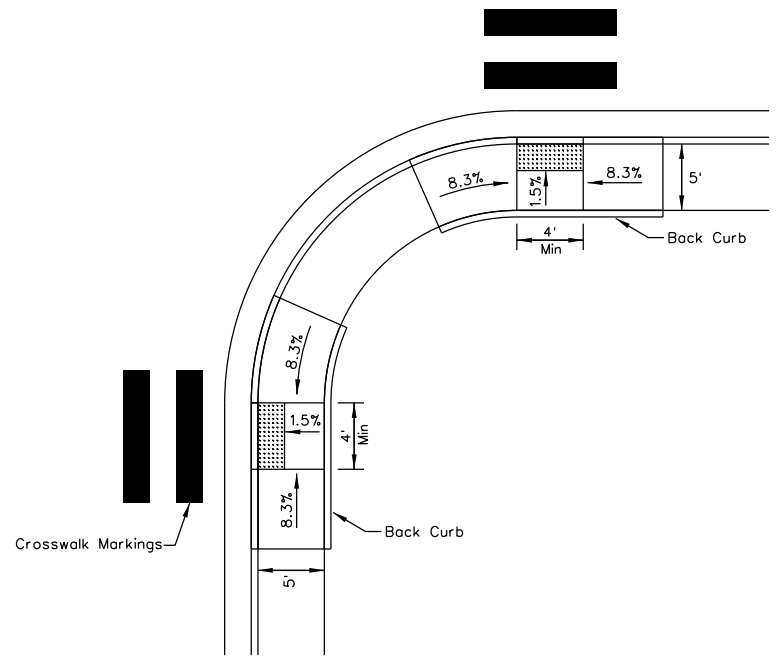

CURB RAMP OUTSIDE RADIUS

NOTES:

1. For additional notes see sheet R-5.2.1
2. 5 foot sidewalk width shall not include 6 inch back curb.

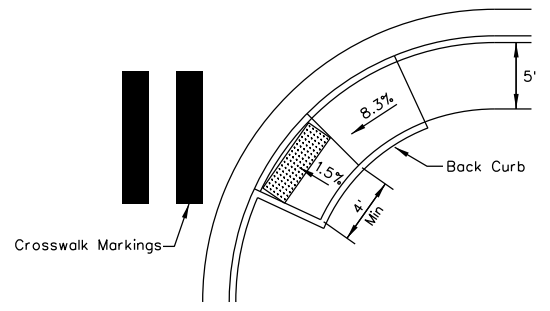

MODIFIED CURB RAMP WITHIN RADIUS

STATE OF NEVADA DEPARTMENT OF TRANSPORTATION		
PARALLEL CURB RAMP		
R-5.2.2.3	(613)	Signed Original On File
ADOPTED 7/96	REVISED 10/15	CHIEF ROAD DESIGN ENGR.

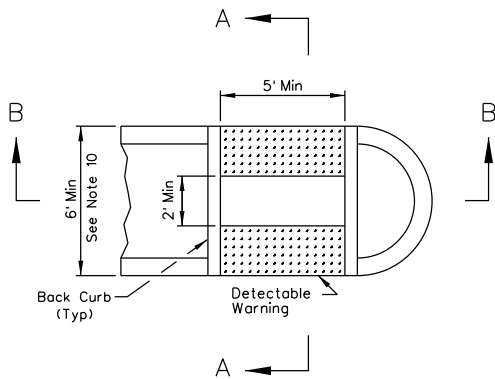

MEDIAN CROSSING PLAN VIEW
(CUT-THROUGH)

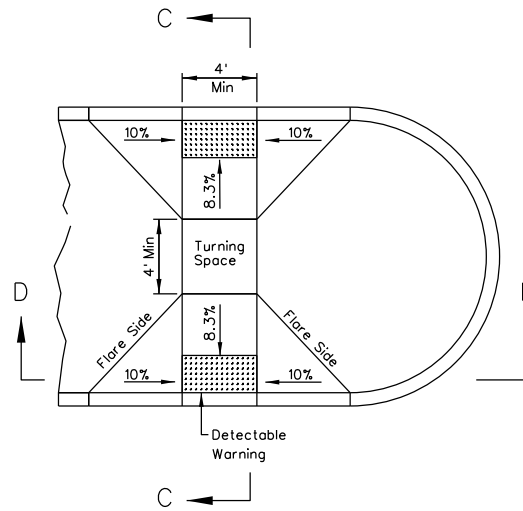

MEDIAN CROSSING PLAN VIEW
(PERPENDICULAR RAMP)

NOTES:

1. All curb ramps shall be 8.3% or flatter. All slope rates are relative to level.
2. Grates, manholes, valve covers or similar appurtenances shall not be located in area at the base of the curb ramp or landing area.
3. Transitions from ramps to gutters or roadway surface shall be flush and free of abrupt changes.
4. Plantmix bituminous open-graded surface shall be flush with the edge of the gutter pan in the area of the curb ramp.
5. Rough broom texture on curb ramps and wings. Texture shall provide a visual contrast to the median island.
6. Concrete shall be class A or AA.
7. Avoid drainage pockets in crosswalk areas.
8. See plans for location of curb ramps.
9. 15 foot maximum to accommodate 8.3% or flatter concrete ramp.
10. When the island width is less than 6 feet, no detectable warnings are required.

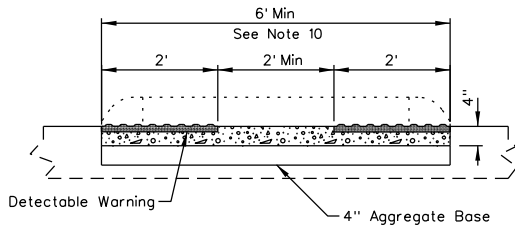

SECTION A-A

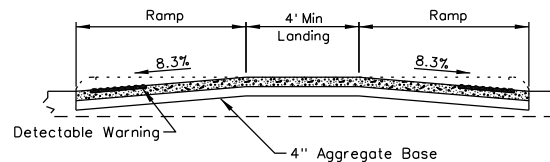

SECTION C-C

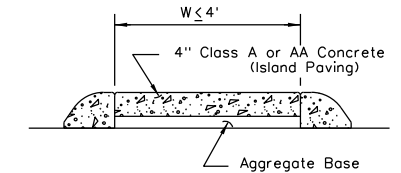
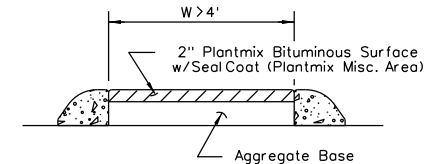

TYPICAL ISLAND PAVING DETAILS

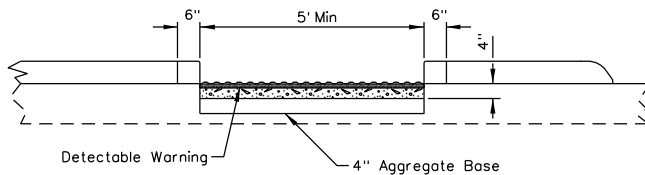

SECTION B-B

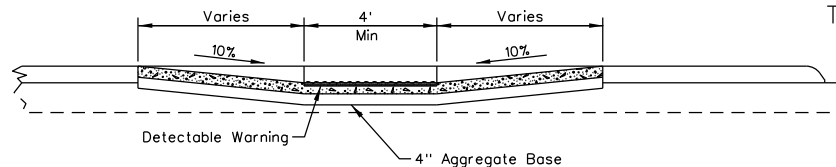

SECTION D-D

STATE OF NEVADA DEPARTMENT OF TRANSPORTATION		
MEDIAN ISLANDS CURB RAMPS AND ISLAND PAVING		
R-5.2.3	(613)	Signed Original On File
ADOPTED 7/96	REVISED 10/15	CHIEF ROAD DESIGN ENGR.

R-67

NOTES:

1. See sheet R-5.2.3 for notes.

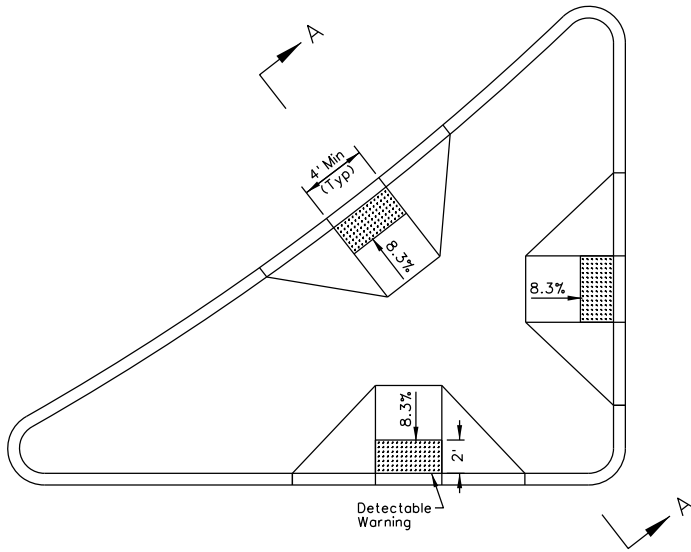

CHANNELIZATION ISLAND
(PERPENDICULAR RAMP)

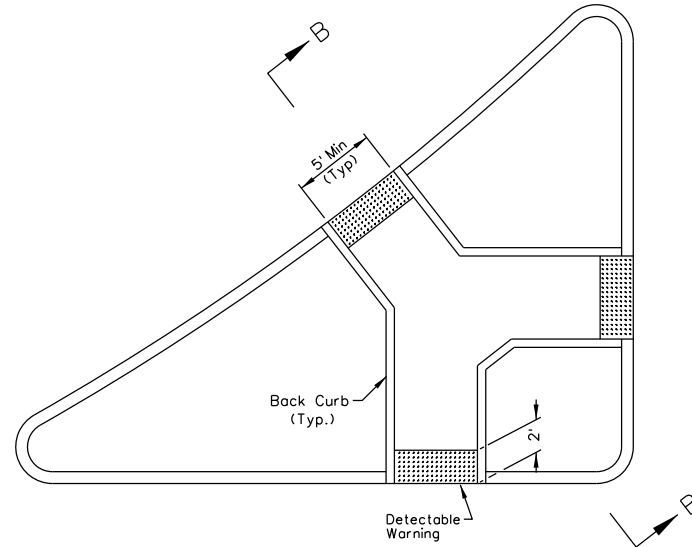

CHANNELIZATION ISLAND
(CUT-THROUGH)

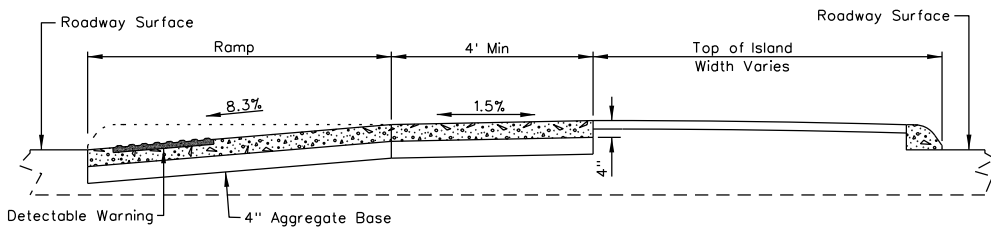

SECTION A-A

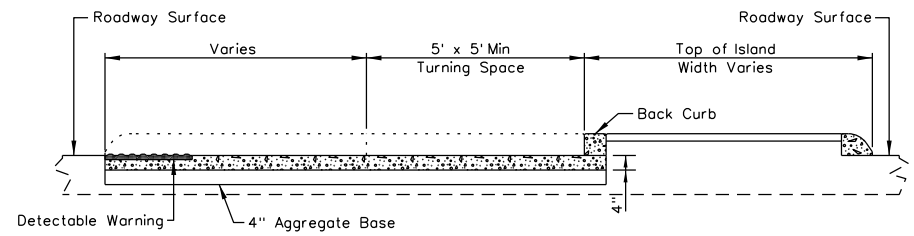

SECTION B-B

STATE OF NEVADA
DEPARTMENT OF TRANSPORTATION

CHANNELING ISLAND
CURB RAMPS

R-5.2.4	(613)	Signed Original On File
ADOPTED 2/03	REVISED 10/15	CHIEF ROAD DESIGN ENGR.

R-68

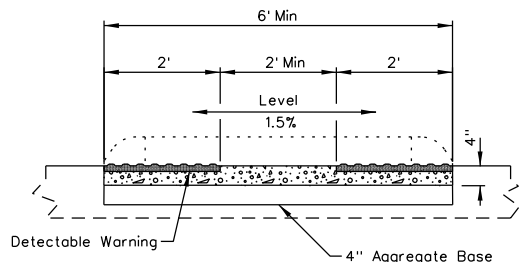
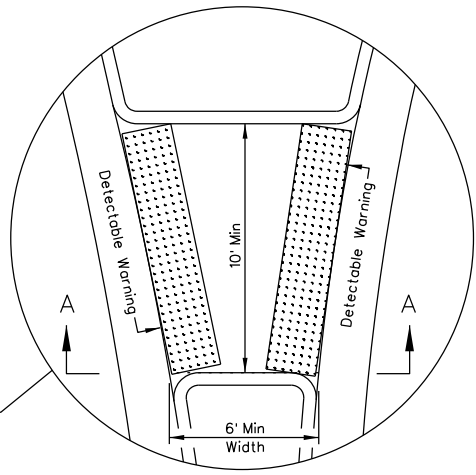
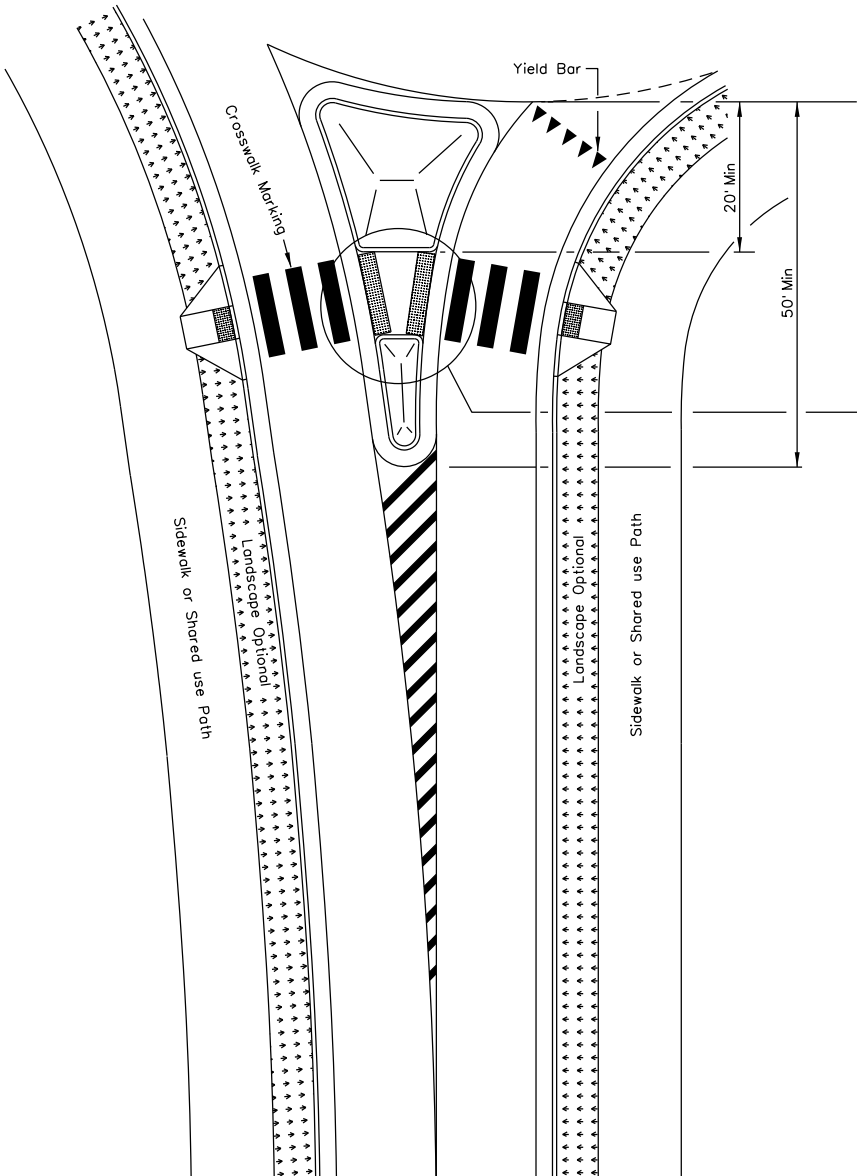

SECTION A-A

SPLITTER ISLAND CROSSING

NOTES

1. 4 inch sloping concrete combined curb and gutter should be used between circulatory roadway and truck apron unless otherwise noted. Curb and gutter should be used between the truck apron and central island.
2. The cross slope of the landing area shall not exceed 2% in the sidewalk area.
3. Splitter island size and shape will be determined by the roadway deflection.
4. Splitter island should be a raised median with concrete hardscaping (preferred). Splitter island should extend a minimum of 50 feet from the yield line.
5. Detectable warning surface shall be installed at both sides of the splitter island pedestrian refuge area.
6. When circulatory roadway is concrete, the transverse contraction joints should line up with contraction joints in the truck apron. The joints in the truck apron should not be doweled. The combined curb and gutter should be tied to the roadway concrete.

STATE OF NEVADA DEPARTMENT OF TRANSPORTATION		
SPLITTER ISLAND CROSSING		
R-5.2.4.1	(613)	Signed Original On File
ADOPTED 2/03	REVISED 10/15	CHIEF ROAD DESIGN ENGR.

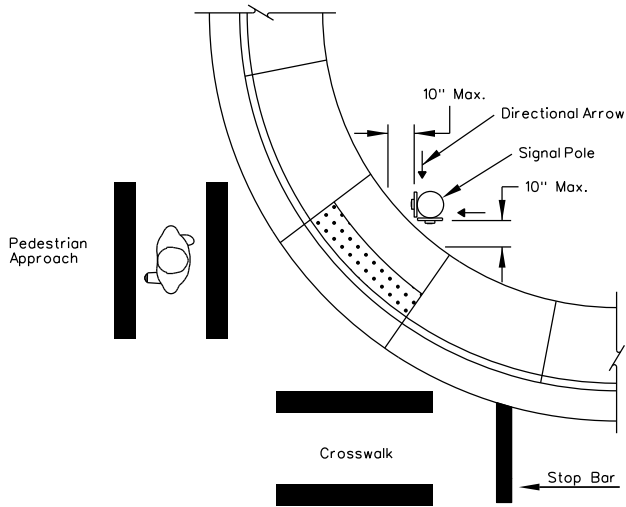

Pedestrian Push Buttons Shall Be Installed on the Crosswalk Side of the Signal Pole, With the Proper Directional Arrow Positioned Correctly.

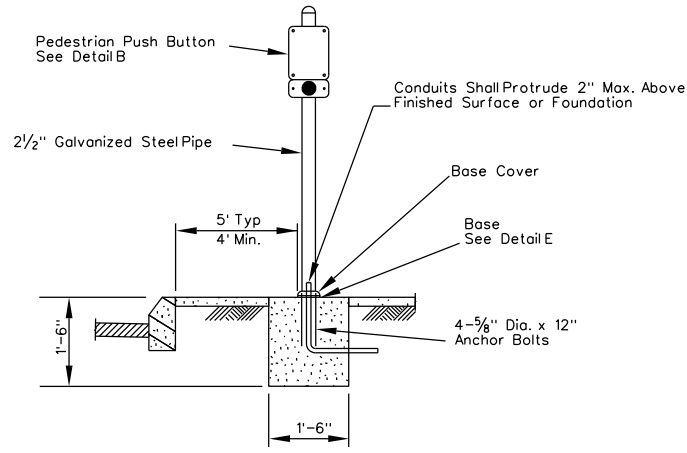

PEDESTRIAN PUSH BUTTON POST

NOTES:

1. Arrow to be left or right or both as required.
2. Per plans or maintaining agency, 5" x 7" or 9" x 12" sign, black symbols on white background.

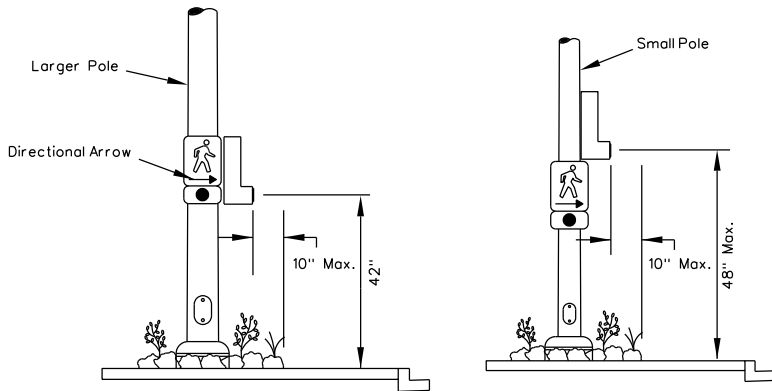

TYPE 1

TYPE 2

TYPE 1- Position Pedestrian Push Buttons on Signal Pole When the Width of the Pole Allows (2) Pedestrian Buttons to Be Mounted At the Same Height.

TYPE 2- Position Pedestrian Push Buttons on Signal Pole When the Width of the Pole Does Not Allow (2) Pedestrian Buttons to Be Mounted At the Same Height. Mount Lower Push Button as High as Possible.

PUSH BUTTON POSITIONING DETAIL

Contractor to verify pole size with Resident Engineer for correct pedestrian push button installation.

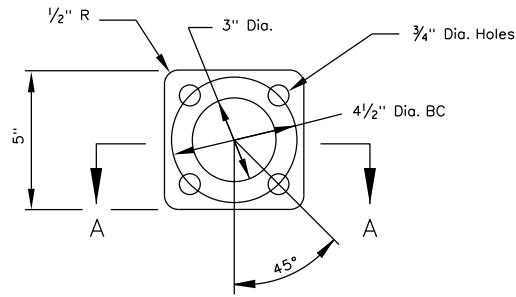

DETAIL E

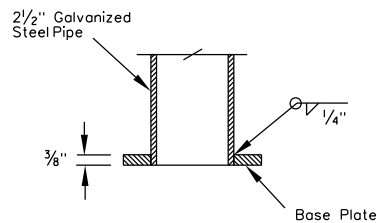

SECTION A-A WITH PIPE

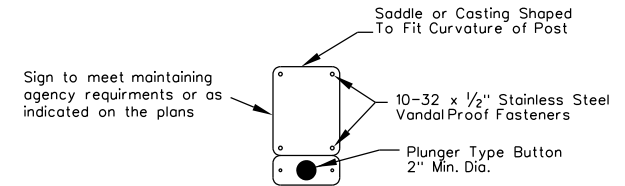

DETAIL B

STATE OF NEVADA DEPARTMENT OF TRANSPORTATION		
PEDESTRIAN PUSH BUTTON DETAILS		
T-31.4.2	(623)	Signed Original On File
ADOPTED 8/98	REVISED 10/15	CHIEF TRAFFIC OPS ENGR.

T-31

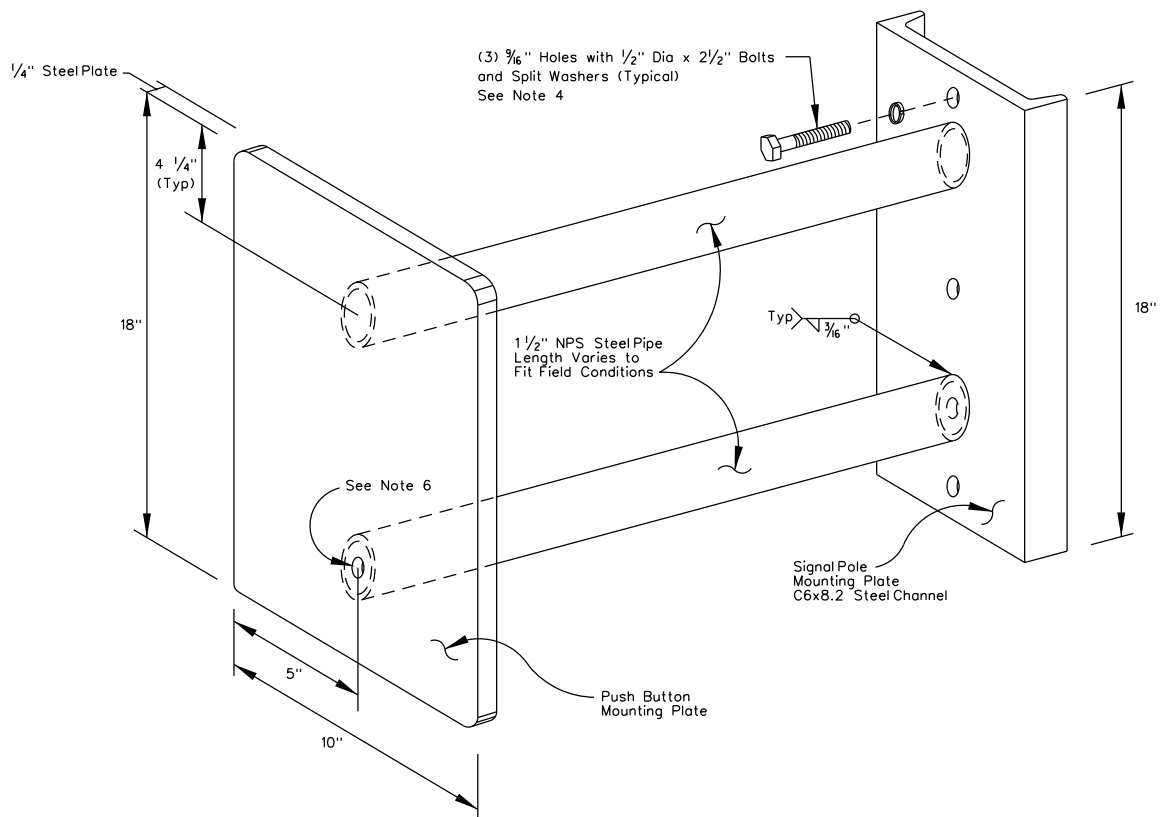

NOTES:

1. 1/2 inch radius on all corners. smooth and neatly round exposed edges to a 1/8 inch radius.
2. All material shall conform to the standard specifications for road and bridge construction. Unless otherwise specified.
3. 1 1/2 inch NPS steelpipe use schedule 40 and 2 inch NPS steelpipe use schedule 80. 2 inch NPS pipe is only used with the adjustable extender.
4. Drill and tap holes 20TPI into signalpole.
5. Attach push button to mounting plate per manufactures recommendations.
6. Drill 1/2 inch holes in mounting plates at lower extension pipe for conductors. Smooth edges to prevent damage to insulation.

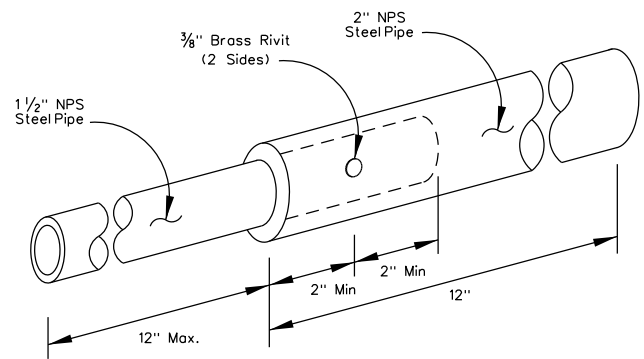

ADJUSTABLE EXTENDER (OPTIONAL)

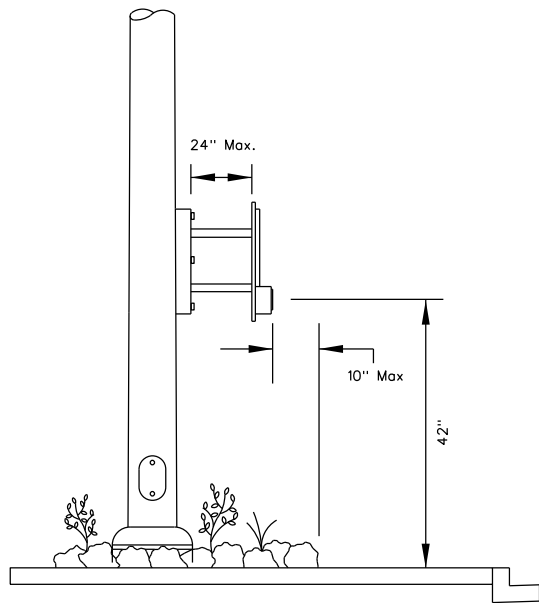
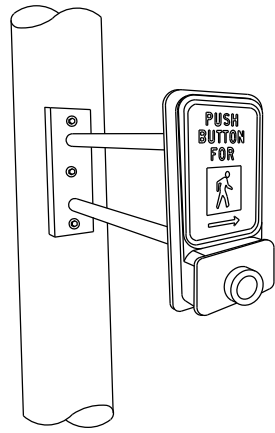

ELEVATION

* No Direct Payment. To be Included on Pedestrian Push Button When Required to Meet ADA Requirements.

STATE OF NEVADA DEPARTMENT OF TRANSPORTATION		
PEDESTRIAN PUSH BUTTON EXTENSION		
T-31.4.3	(623)	Signed Original On File
ADOPTED 5/09	REVISED 10/15	CHIEF TRAFFIC OPS ENGR.

(3) 3/16" Holes with 1/2" Dia x 2 1/2" Bolts and Split Washers (Typical)
See Note 4

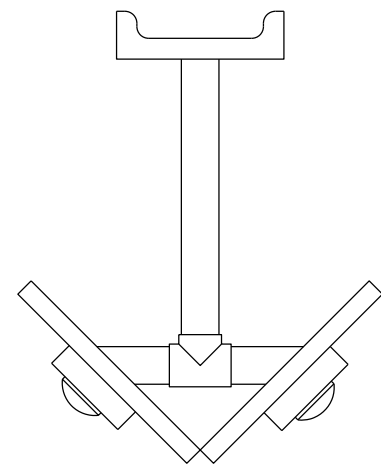
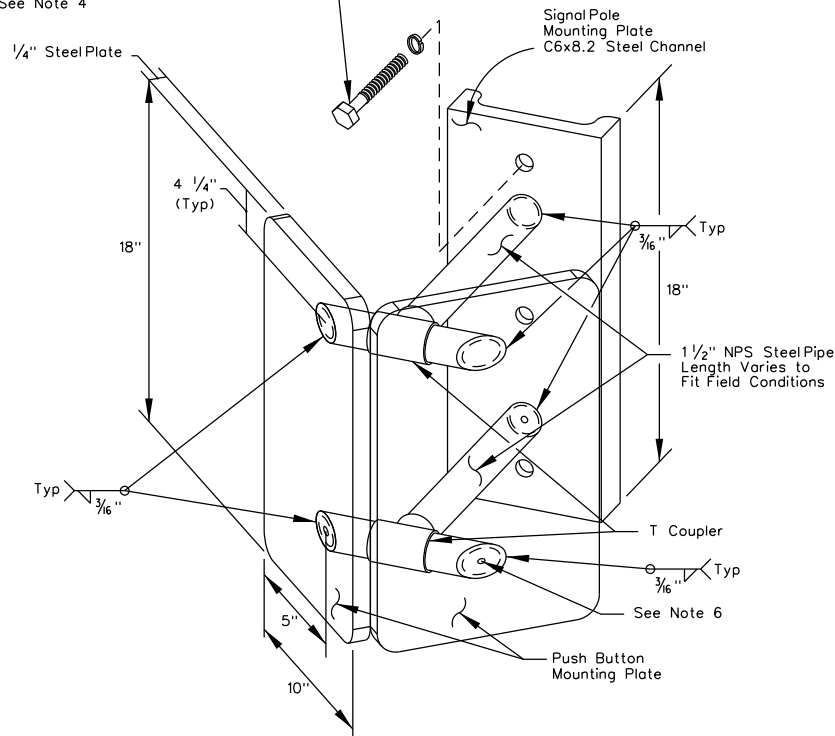

PLAN VIEW

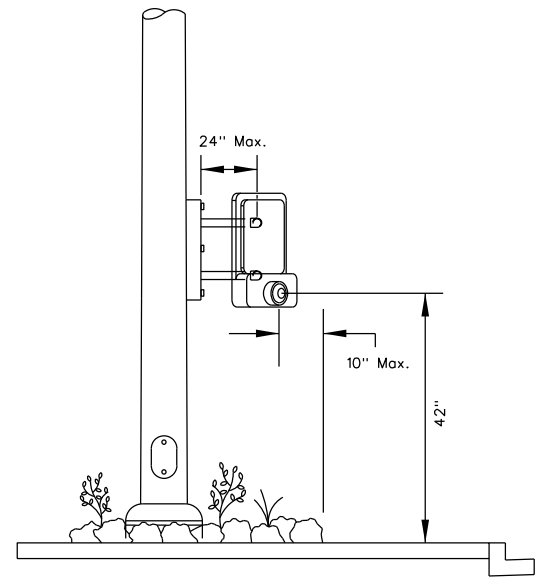

ELEVATION

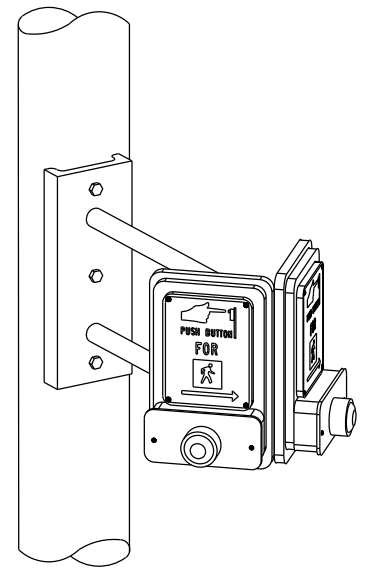

NOTES:

- 1/2 inch radius on all corners. Smooth and neatly round exposed edges to a 1/8 inch radius.
- All material shall conform to the Standard Specifications for Road and Bridge Construction. Unless otherwise specified.
- 1 1/2 inch NPS steel pipe use schedule 40 and 2 inch NPS steel pipe use schedule 80. 2 inch NPS pipe is only used with the adjustable extender.
- Drill and tap holes 20TPI into signal pole.
- Attach push button to mounting plate per manufactures recommendations.
- Drill 1/2 inch holes in mounting plates at lower extension pipe for conductors. Smooth edges to prevent damage to insulation.

STATE OF NEVADA DEPARTMENT OF TRANSPORTATION		
PEDESTRIAN PUSH BUTTON EXTENSION (DUAL BUTTONS)		
T-31.4.4	(623)	Signed Original On File
ADOPTED 10/15	REVISED	CHIEF TRAFFIC OPS ENGR

* No Direct Payment. To be included on Pedestrian Push Button When Required to Meet ADA Requirements.

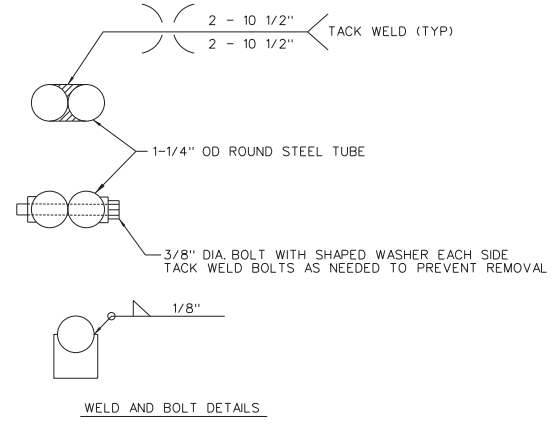
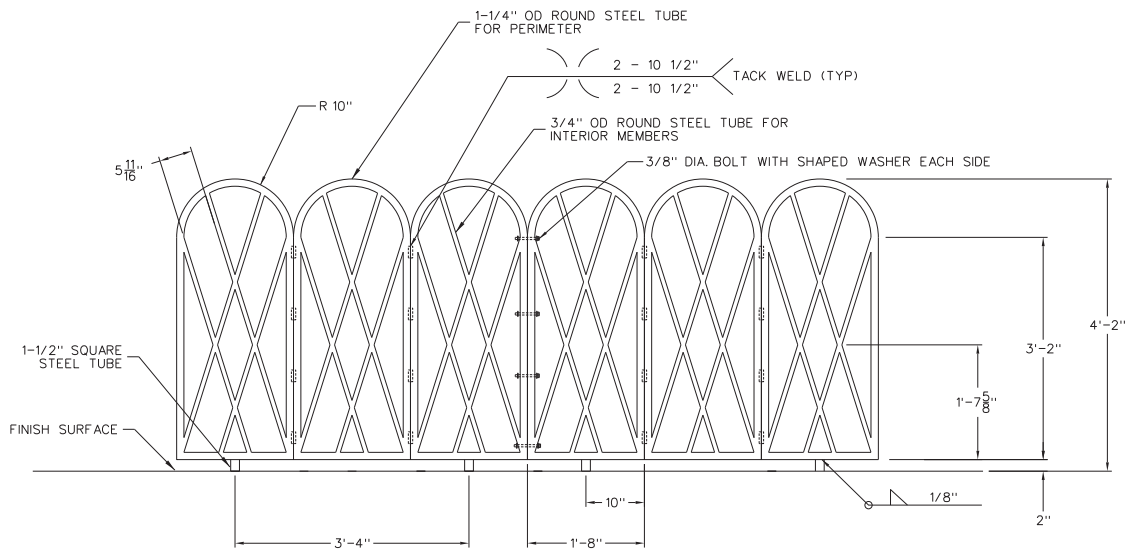

- NOTES:
1. ALL STEEL RAILING ASSEMBLY SHALL BE GALVANIZED AFTER FABRICATION.
 2. ALL EXPOSED SURFACES OF STEEL RAILING SHALL HAVE DESERT VARNISH APPLIED PRIOR TO INSTALLATION.
 3. APPLY DESERT VARNISH ON ALL BOLTS AND CONNECTIONS IN FIELD.

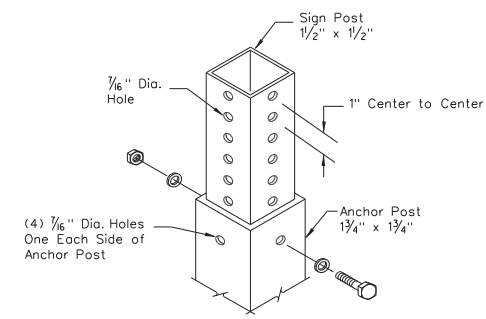
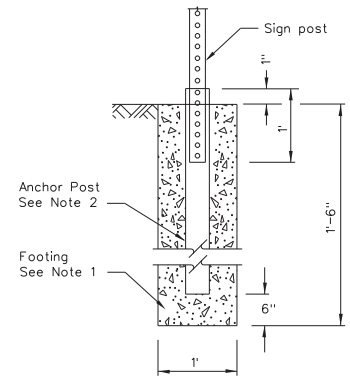
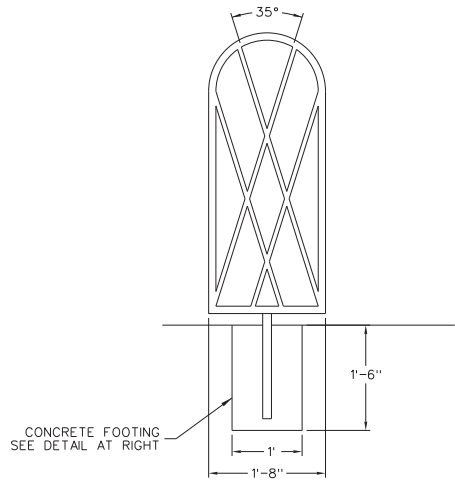

STATE OF NEVADA
DEPARTMENT OF TRANSPORTATION

MEDIAN
PEDESTRIAN
FENCING