



**NEVADA
DOT**

SAFE AND CONNECTED



Boschung Anti-Icing System

**Presented to NDOT Board
August 13, 2018**

Presented by Thor A. Dyson, PE, CPM





System Description

- A proactive, approach providing an increase in road safety, improved traffic flow, savings on anti-icing solution, and reduced environmental impact
- 4 sites
 - Galena Forest
 - Steamboat Hills
 - Galena Creek
 - Browns Creek
- Local computerized control at each site for automated activation
- Central Boschung Borrma computer software to visualize and monitor site activity



System Schematic & Photos

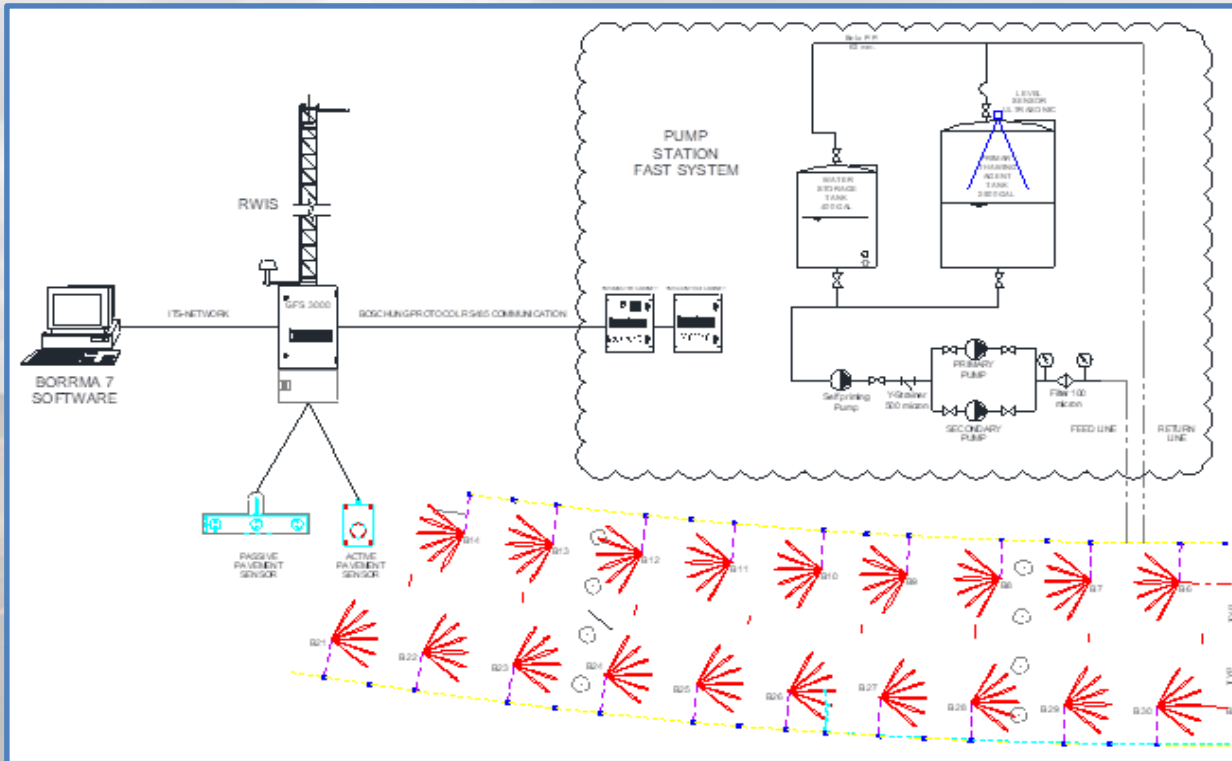



System Benefits

- Proactive pavement surface treatment system to prevent the formation of ice or bonded snow
- Automated Anti-Icing System based on computerized real time analysis of field weather conditions. No human interaction is required to activate the system.
- Potassium acetate is less corrosive for steel and concrete than sodium chloride
- Potassium acetate has a significantly lower freezing point than sodium chloride



Boschung Clients

- Alaska DOT
- Caltrans
- Colorado DOT
- Minnesota DOT
- Montana DOT
- Nebraska DOT
- New York DOT
- NDOT
- North Dakota DOT
- Ontario, Canada
- Pennsylvania DOT
- Utah DOT
- Vermont DOT



Some System Stats

- System holds 14,000 gallons of potassium acetate
- System holds 2,000 gallons of water
- System fires as needed based on environmental conditions
- System performs a maintenance spray every 3 days if it has not been exercised based on real time environmental conditions



Potassium Acetate Consumption (Gallons vs Year)

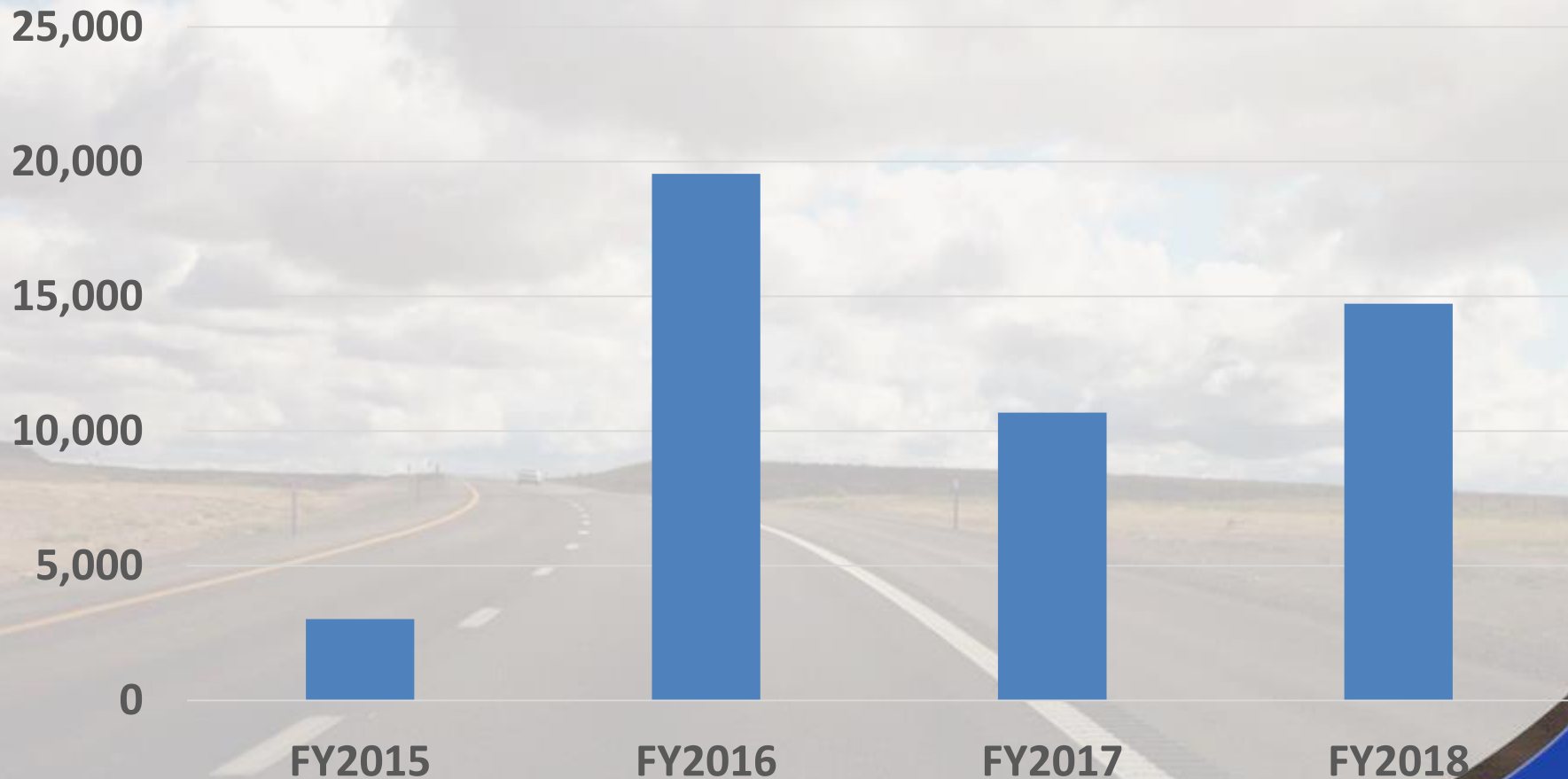



Proposed Contract with Boschung

- | | |
|---|---------------|
| 1) Fall season switch over | \$11,911/year |
| 2) Spring seasonal switch over | \$11,911/year |
| 3) Remote tech support | \$2,160/year |
| 4) Unscheduled call out reg | \$120/hr |
| Unscheduled call out OT | \$180/hr |
| 5) Certified operator training | \$3,960/year |
| 6) Parts procurement - per price list in contract | |



Boschung Sole Source

- Only Boschung can work on specialty electronics and European components
- Sophisticated proprietary system
- Boschung is the appropriate expert resource for assisting NDOT to successfully maintain the system reliability while minimizing system down time



Boschung Response Time

- Boschung will respond immediately during their business hours to NDOT phone calls requesting support
- Facetime and Skype are also available if helpful for troubleshooting problems
- Boschung America will respond in person to NDOT calls for unscheduled service within 7 business days unless otherwise agreed by NDOT and Boschung America



- Boschung Anti-Icing System is a key strategy for the NDOT Zero Fatalities Program
- To date, there have been zero *fatalities* during winter weather events on the four structures using the Boschung Anti-icing system!



Alternatives Considered

- **RECOMMENDATION:** Accept proposed on-call contract with Boschung
- **CONSIDERED BUT NOT RECOMMENDED:**
 - Negotiate sole source agreements as needed for required service
 - Abandon Boschung system
 - Do nothing and repair Boschung system as failures occur



Thor A. Dyson, PE, CPM

Assistant Director of
Operations

tdyson@dot.nv.gov





Boschung Rep Introduction

Chris Vitek

Boschung America Sales Representative

cgv@BoschungAmerica.com

724.658.3300 x506



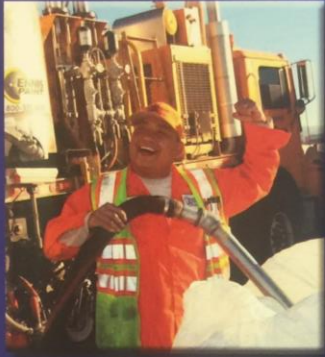

Temporary Highway Maintenance Worker I & II

- *Must be 18 years of age to apply*
- *Class A or B Commercial Drivers License will be required upon application*

Applications now being accepted online



Your Road to Success!



www.nevadadot.com/jobs



Apply online: nevadadot.com/jobs
NDOT recruitment: (775) 888-7430

The State of Nevada is an EEO/AA Employer

Questions?

NOW HIRING

**Construction Aid (temp)
starting salary \$13.03**

**Highway Maintenance
Worker I (winter temp &
permanent) Starting
Salary \$14.60**



NEVADA DOT

SAFE AND CONNECTED



www.nevadadot.com

