

Chapter 20

BEARINGS

NDOT STRUCTURES MANUAL

September 2008

Table of Contents

<u>Section</u>	<u>Page</u>
20.1 GENERAL	20-1
20.1.1 Movements	20-1
20.1.2 Effect of Camber and Construction Procedures	20-1
20.1.3 Design Thermal Movements.....	20-1
20.1.4 Estimation of Total Design Movement.....	20-2
20.1.5 Serviceability, Maintenance and Protection Requirements	20-2
20.1.6 Seismic Requirements.....	20-2
20.1.7 Anchor Bolts	20-2
20.1.8 Bearing Plate Details	20-3
20.1.9 Leveling Pad at Integral Abutments.....	20-3
20.2 BEARING SELECTION.....	20-4
20.2.1 General.....	20-4
20.2.2 Steel-Reinforced Elastomeric Bearings.....	20-5
20.2.3 Plain Elastomeric Bearing Pads	20-5
20.2.4 High-Load, Multi-Rotational (HLMR) Bearings	20-5
20.2.4.1 General	20-5
20.2.4.2 Pot Bearings	20-5
20.2.4.3 Spherical Bearings.....	20-8
20.2.4.4 Disc Bearings.....	20-8
20.2.4.5 Polytetrafluoroethyl (PTFE) Sliding Surfaces.....	20-9
20.2.5 Seismic Isolation Bearings	20-9
20.3 PLAIN ELASTOMERIC BEARING PADS AND STEEL-REINFORCED ELASTOMERIC BEARINGS	20-10
20.3.1 General.....	20-10
20.3.2 Shape Factor	20-10
20.3.3 Holes in Elastomer	20-10
20.3.4 Edge Distance	20-10
20.3.5 Elastomer	20-10
20.3.6 Steel-Reinforced Elastomeric Bearings.....	20-11
20.3.7 Plain Elastomeric Bearing Pads	20-12
20.3.8 Design of Steel-Reinforced Elastomeric Bearings.....	20-12
20.4 DESIGN EXAMPLE	20-14
20.4.1 Given Data.....	20-14
20.4.2 Trial Bearing Geometry	20-14
20.4.3 Solution.....	20-15

Chapter 20

BEARINGS

20.1 GENERAL

Reference: LRFD Articles 14.4 and 14.6

Bridge bearings accommodate the movements of the superstructure and transmit the loads to the substructure. The type of bearing selected depends upon the magnitude and type of movement and the magnitude of the load.

20.1.1 Movements

The consideration of movement is important for bearing design. Movements include both translations and rotations. The sources of movement include initial camber or curvature, construction loads, misalignment, construction tolerances, settlement of supports, thermal effects, elastic shortening due to post-tensioning, creep, shrinkage, and seismic and traffic loading.

20.1.2 Effect of Camber and Construction Procedures

The initial camber of bridge girders induces bearing rotation. Initial camber may cause a larger initial rotation on the bearing, but this rotation may decrease as the construction of the bridge progresses. Rotation due to camber and the initial construction tolerances are sometimes the largest component of the total bearing rotation. Evaluate both the initial rotation and its short duration. At intermediate stages of construction, the designer must add deflections and rotations due to the progressive weight of the bridge elements and construction equipment to the effects of live load and temperature. The direction of loads, movements and rotations must also be considered, because it is inappropriate to simply add the absolute maximum magnitudes of these design requirements. The designer should anticipate the worst possible (but yet realistic) condition. Do not consider combinations of absolute maximums that can not realistically occur. In special cases, it may be economical to install the bearing with an initial offset, or to adjust the position of the bearing after construction has started, to minimize the adverse effect of these temporary initial conditions.

20.1.3 Design Thermal Movements

Reference: LRFD Article 3.12.2

A change in temperature causes an elongation or shortening of a bridge component, leading to translation at its supports. The design thermal movement shall be estimated in accordance with [Section 19.1.2](#).

Setting temperatures of 40°, 55°, 70°, 85° and 100°F, consistent with the minimum and maximum temperatures at the bridge site, shall be assumed for the installation of the bearings. At the time of construction, the appropriate setting conditions can be chosen based upon the ambient temperature.

Note that a given temperature change causes thermal movement in all directions. Because the thermal movement is a function of the expansion length as shown in LRFD Equation 3.12.2.3-1, a short, wide bridge may experience greater transverse movement than longitudinal movement.

20.1.4 Estimation of Total Design Movement

In addition to the thermal movement determined in [Section 20.1.3](#), the effects of creep (CR) and shrinkage (SH) should be considered in the total movement for bridges in accordance with [Section 19.1.3](#).

20.1.5 Serviceability, Maintenance and Protection Requirements

Reference: LRFD Article 2.5.2.3

Bearings under deck joints may be exposed to dirt, debris and moisture that promote corrosion and deterioration. As a result, these bearings should be designed and installed to minimize environmental damage and to allow easy access for inspection.

The service demands on bridge bearings are very severe and result in a service life that is typically shorter than that of other bridge elements. Therefore, allowances for bearing replacement must be part of the design process. Refer to [Section 15.5.5](#) for specific requirements on jacking.

20.1.6 Seismic Requirements

Reference: LRFD Article 14.6.5

Bearing selection and design shall be consistent with the intended seismic response of the entire bridge system and related to the characteristics of both the superstructure and the substructure.

Bearings (other than seismic isolation bearings or structural fuse bearings) may be classified as rigid or deformable. Rigid bearings transmit seismic loads without any movement or deformations. Deformable bearings transmit seismic loads limited by plastic deformations or a restricted slippage of bearing components.

Where rigid bearings are used, the seismic forces from the superstructure shall be assumed to be transmitted through diaphragms or cross frames and their connections to the bearings and then to the substructure without reduction due to local inelastic action along this load path.

Steel-reinforced elastomeric bearing assemblies are typically designed to accommodate imposed seismic loads and displacements. Alternatively, if survival of the elastomeric bearing itself is not required, other means such as restrainers, shock transmission units or dampeners shall be provided to prevent unseating of the superstructure.

These provisions shall not apply to seismic isolation bearings or structural fuse bearings.

20.1.7 Anchor Bolts

Reference: LRFD Article 14.8.3

Anchor bolts shall be used to transfer horizontal forces through bearing assemblies when external devices such as shear keys are not present. In addition, anchor bolts are used as hold downs for bearings.

Holes for anchor bolts in steel elements of bearing assemblies shall be $\frac{1}{4}$ in larger in diameter than the diameter of the anchor bolt. The centerlines of anchor bolts shall be a minimum of 2 in from the edge of the girder. A larger offset may be necessary to facilitate installation. The designer must consider the space necessary for nuts, washers, base plate welds and construction tolerances and establish anchor bolt locations accordingly. Maintain $\frac{1}{2}$ -in clearance from the edge of the elastomeric bearing to the edge of the anchor bolt.

Anchor bolts shall be designed to behave with ductility. The anchor bolts shall be designed for the combined effect of bending and shear for seismic loads as specified in LRFD Article 14.6.5.3.

Sufficient reinforcement shall be provided around the anchor bolts to develop the horizontal forces and anchor them into the mass of the substructure unit. Potential concrete crack surfaces next to the bearing anchorage shall be identified and their shear friction capacity evaluated. Conflicts between anchor bolt assemblies and substructure reinforcement is common, especially for skewed bridges. Therefore, the bridge designer must ensure that all reinforcing steel can fit around the bearing assemblies.

20.1.8 Bearing Plate Details

The bearing plate shall be at least 1 in wider than the elastomeric bearing on which the plate rests. Use a minimum bearing plate thickness of $1\frac{1}{2}$ in. When the instantaneous slope of the grade plus the final in-place camber exceeds 1%, bevel the bearing plate to match the grade plus final camber. For beveled bearing plates, maintain a minimum of $1\frac{1}{2}$ in thickness at the edge of the bearing plate.

At expansion bearings, the designer shall provide slotted bearing plates. Determine the minimum slot size according to the amount of movement and end rotation calculated. The slot length, L, should be:

$$L = (\text{diameter of anchor bolt}) + 1.2 (\text{total movement}) + 1.0 \text{ in}$$

The multiplier of 1.2 represents the load factor from LRFD Table 3.4.1-1 for TU, CR and SH. The total movement should include an effect of girder end rotation at the level of the bearing plate. The slot length should be rounded to the next higher $\frac{1}{4}$ in. To account for the possibility of different setting temperatures at each stage, provide offset dimensions in the contract documents for stage-constructed projects. For all other projects, the designer must also consider the need to provide offset dimensions.

20.1.9 Leveling Pad at Integral Abutments

A plain elastomeric pad shall be detailed under the bearing plate of girders at integral abutments to provide a level and uniform bearing surface. Structural grout is not an acceptable substitute.

20.2 BEARING SELECTION

20.2.1 General

Where possible, steel-reinforced elastomeric bearings should be used for all girder bridges. Bridges with large bearing loads and/or multi-directional movement may require other bearing devices such as pot, spherical or disc bearings.

Bearing selection is influenced by many factors including loads, geometry, maintenance, available clearance, displacement, rotation, deflection, availability, policy, designer preference, construction tolerances and cost. In general, vertical displacements are restrained, rotations are allowed to occur as freely as possible, and horizontal displacements may be either accommodated or restrained. Distribute the loads among the bearings in accordance with the superstructure analysis.

See [Figure 20.2-A](#) for a general summary of bearing capabilities. The values shown in the table are for preliminary guidance only. The final step in the selection process consists of completing a design of the bearing in accordance with the *LRFD Specifications*. The resulting design will provide the geometry and other pertinent specifications for the bearing. If the load falls outside of the optimal ranges, the bridge designer should contact the bearing manufacturer.

Typically, concrete shear keys are used with elastomeric bearings to transfer horizontal forces from a concrete box girder superstructure to the substructure. Bearing plates and anchor bolts are used for steel and precast concrete girder superstructures.

The following Sections summarize typical NDOT practices for the selection of a bearing type.

Type		Load (kips)	Translation (in)		Rotation Limit (Rad)	Cost	
		Optimal Design Range ¹	Min	Max		Initial	Maintenance
Steel-Reinforced Elastomeric Bearing		50 to 650	0	4	0.04	low	Low
High-Load, Multi-Rotational (HLMR) Bearings	Pot Bearing	270 to 2250	0 ²	0 ²	0.04 - 0.05	high	High
	Disc Bearing	270 to 2250	0 ²	0 ²	0.03	high	High
	Spherical Bearing	270 to 2250	0 ²	0 ²	> 0.05	high	high
Plain Elastomeric Pad		0 to 150	0	¾	0.0175	low	low

¹ Higher and lower values may be applicable if necessary.

² High-Load, Multi-Rotational (HLMR) bearings, such as pot bearings, disc bearings and spherical bearings have no inherent translational capability. Expansion bearings are achieved by using them in conjunction with flat PTFE sliding surfaces.

SUMMARY OF BEARING CAPABILITIES

Figure 20.2-A

20.2.2 Steel-Reinforced Elastomeric Bearings

Reference: LRFD Article 14.7.6

Where possible, steel-reinforced elastomeric bearings should be used for all girder bridges. They are usually a low-cost option and require minimal maintenance. [Figure 20.2-B](#) illustrates a steel-reinforced elastomeric bearing assembly used with a steel girder. [Section 20.3](#) discusses these bearings in more detail. [Section 20.4](#) provides a design example for a steel-reinforced elastomeric bearing for a steel girder bridge.

Elastomeric expansion bearings shall be provided with adequate seismic-resistant anchorages to resist the horizontal forces in excess of those accommodated by shear in the pad. The sole plate and the base plate shall be made wider to accommodate the anchor bolts.

Elastomeric fixed bearings shall be provided with a horizontal restraint adequate for the full horizontal load.

20.2.3 Plain Elastomeric Bearing Pads

Reference: LRFD Article 14.7.6

Plain elastomeric bearing pads are usually a low-cost option, and they require minimal maintenance. However, their use is restricted to lighter bearing loads for practical reasons. They are used as leveling pads at integral abutments for girder bridges.

20.2.4 High-Load, Multi-Rotational (HLMR) Bearings

20.2.4.1 General

These bearing types are generally avoided due to their cost. They may be appropriate at bridges with large vertical loads; i.e., in excess of 650 kips.

High-load, multi-rotational (HLMR) bearings are used in applications where loads exceed the capabilities of steel-reinforced elastomeric bearings. The choice among HLMR bearings is based upon the rotational capabilities presented in [Figure 20.2-A](#).

The contract documents for bridges with HLMR bearings should not include specific details for the bearings. Only schematic bearing details, combined with specified loads, movements and rotations, need to be shown. The bearing is designed by the manufacturer, which advantageously uses the cost-effective fabrication procedures that are available in the shop.

[Figure 20.2-C](#) illustrates the schematics for HLMR bearings.

20.2.4.2 Pot Bearings

Reference: LRFD 14.7.4

Pot bearings consist of a pot/piston assembly within which an elastomeric disc is encapsulated and fitted with an anti-extrusion sealing device. Under load, this encapsulated elastomeric disc

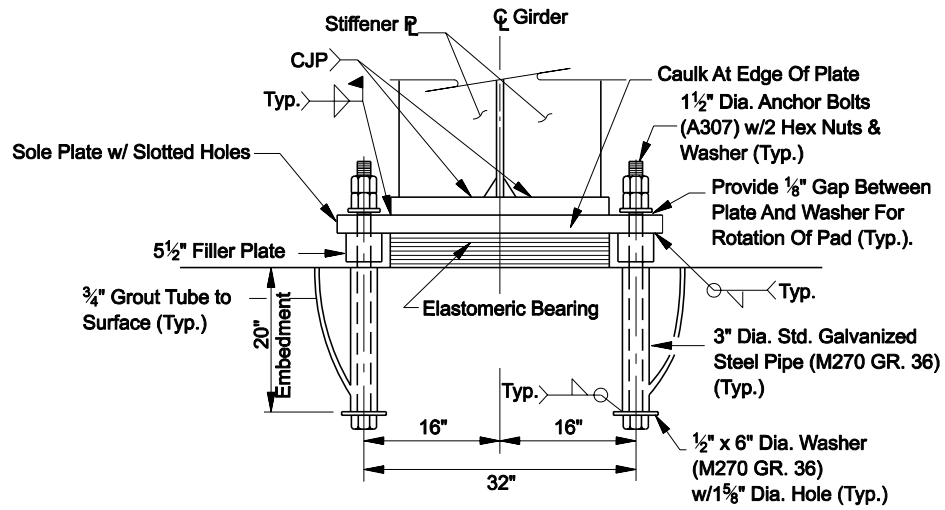

TYPICAL EXPANSION BEARING ASSEMBLY

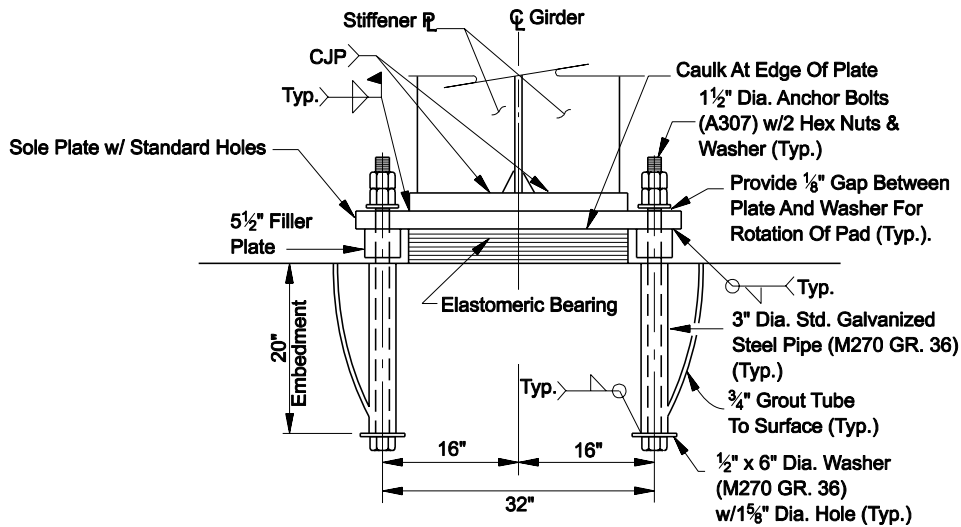

TYPICAL FIXED BEARING ASSEMBLY

ELASTOMERIC BEARING ASSEMBLY

Figure 20.2-B

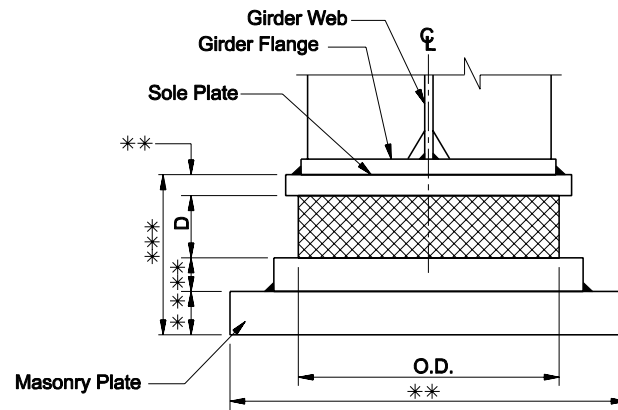

Not to Scale

** To be Determined by Designer
Note: Anchor Bolts are not Shown.

*** The Overall Height Should be Based
on the Largest "D" Values From All
Potential Bearing Manufacturers.

 Indicates Fixed, Guided or
Free Portion of the
Bearing Designed by
The Manufacturer

HIGH-LOAD, MULTI-ROTATIONAL BEARING

Figure 20.2-C

acts in a similar manner to an incompressible confined fluid, enabling the pot and piston to rotate relative to each other. Pot bearings enable rotation in any direction. The pot and piston feature fittings for securing the bearing to the bridge structure.

Fixed pot bearings are constrained horizontally. Identical in construction to fixed bearings, free-sliding pot bearings are fitted with a PTFE sliding surface in contact with a steel plate, enabling the bearing to slide in all directions. Guided sliding pot bearings are also identical in construction to free-sliding bearings but are also fitted with one or more guides to limit the bearing movement to only one direction.

Pot bearings are able to support large compressive loads, but their elastomer can leak and their sealing rings can suffer wear or damage.

20.2.4.3 Spherical Bearings

Reference: LRFD Article 14.7.3

Spherical bearings, termed "Bearings with Curved Sliding Surfaces," include bearings with both spherical and cylindrical sliding surfaces. Spherical bearings are able to sustain large rotations but require proper clearances and very smooth and accurate machining.

A spherical bearing relies upon the low-friction characteristics of a curved PTFE-stainless steel interface to provide a high level of rotational flexibility in multiple directions. An additional flat PTFE-stainless steel surface can be incorporated into the bearing to provide either guided or non-guided translational movement capability. Woven PTFE is generally used on the curved surfaces of spherical bearings. Woven PTFE exhibits enhanced creep (cold flow) resistance and durability characteristics relative to unwoven PTFE. When spherical bearings are detailed to accommodate translational movement, woven PTFE is generally also specified on the flat sliding surface.

Most spherical bearings are fabricated with the concave surface oriented downward to minimize dirt infiltration between PTFE and the stainless steel surface. Refined modeling of the overall structure must recognize that the center of rotation of the bearing is not coincident with the neutral axis of the girder above.

20.2.4.4 Disc Bearings

Reference: LRFD Article 14.7.8

A disc bearing is composed of an annular shaped urethane disc designed to provide moderate levels of rotational flexibility. A steel shear-resisting pin in the center provides resistance against lateral force. A flat PTFE-stainless steel surface can be incorporated into the bearing to also provide translational movement capability, either guided or non-guided.

Disc bearings are susceptible to uplift during rotation, which may limit their use in bearings with polytetrafluoroethyl (PTFE) sliding surfaces.

20.2.4.5 Polytetrafluoroethyl (PTFE) Sliding Surfaces

Reference: LRFD Article 14.7.2

For expansion high-load, multi-rotational bearings and where the maximum movements of elastomeric bearings are exceeded, the designer may consider using PTFE sliding surfaces with the bearing to obtain translational capability. PTFE sliding surfaces can also be used in conjunction with an elastomeric bearing to obtain translational capability.

The following design information applies to PTFE sliding surfaces:

- Optimal design range for loads: 0 kips to 2250 kips
- Translation: 1 in to > 4 in

20.2.5 Seismic Isolation Bearings

There are various types of seismic isolation bearings, most of which are proprietary. The use of seismic isolation bearings is discussed in the *AASHTO Guide Specifications for Seismic Isolation Design* and the *FHWA Seismic Retrofitting Manual for Highway Structures: Part 1 – Bridges*.

These bearings can assist in achieving seismic objectives in retrofit situations; see [Section 22.9.4.6](#). The Chief Structures Engineer must approve the use of seismic isolation bearings.

20.3 PLAIN ELASTOMERIC BEARING PADS AND STEEL-REINFORCED ELASTOMERIC BEARINGS

Reference: LRFD Articles 14.7.5 and 14.7.6

20.3.1 General

Plain elastomeric bearing pads and steel-reinforced elastomeric bearings have fundamentally different behaviors and, therefore, they are discussed separately. It is usually desirable to orient elastomeric pads and bearings so that the long side is parallel to the principal axis of rotation, because this orientation better accommodates rotation.

20.3.2 Shape Factor

Elastomers are used in both plain elastomeric bearing pads and steel-reinforced elastomeric bearings. The behavior of both pads and bearings is influenced by the shape factor (S) where:

$$S = \frac{\text{Plan Area}}{\text{Area of Perimeter Free to Bulge}}$$

20.3.3 Holes in Elastomer

NDOT prohibits the use of holes in steel-reinforced elastomeric bearings or plain elastomeric bearing pads.

20.3.4 Edge Distance

For elastomeric pads and bearings resting directly on a concrete bridge seat, the minimum edge distance shall be 3 in.

20.3.5 Elastomer

Reference: LRFD Articles 14.7.5.2 and 14.7.6.2

NDOT only uses neoprene for its elastomeric bearing pads and steel-reinforced elastomeric bearings.

All elastomers are visco-elastic, nonlinear materials and, therefore, their properties vary with strain level, rate of loading and temperature. Bearing manufacturers evaluate the materials on the basis of Shore A Durometer hardness, but this parameter is not a good indicator of the shear modulus, G. Use a Shore A Durometer hardness of 50 or 55. This leads to shear modulus values in the range of 0.095 to 0.200 (use the least favorable value for design) ksi @73°F. The shear stiffness of the bearing is its most important property because it affects the forces transmitted between the superstructure and substructure.

Elastomers are flexible under shear and uniaxial deformation, but they are very stiff against volume changes. This feature makes possible the design of a bearing that is flexible in shear but stiff in compression.

Elastomers stiffen at low temperatures. The low-temperature stiffening effect is very sensitive to the elastomer compound, and the increase in shear resistance can be controlled by the selection of an elastomer compound that is appropriate for the climatic conditions. The minimum low-temperature elastomer shall be Grade 3. The designer shall indicate the elastomer grade in the contract documents.

20.3.6 Steel-Reinforced Elastomeric Bearings

The use of steel-reinforced elastomeric bearings in combination with steel bearing plates is preferred for slab-on-girder bridges. Use a 1-in minimum clearance between the edge of the elastomeric bearing and the edge of the bearing plate in the direction parallel to the beam or girder. Use a ½-in minimum clearance between the edge of the elastomeric bearing pad and the anchor bolt in the direction perpendicular to the girder.

Steel-reinforced elastomeric bearings behave differently than plain elastomeric bearing pads. Steel-reinforced elastomeric bearings have uniformly spaced layers of steel and elastomer. The bearing accommodates translation and rotation by deformation of the elastomer. The elastomer is flexible under shear stress but stiff against volumetric changes. Under uniaxial compression without steel reinforcement, the flexible elastomer would shorten significantly and sustain large increases in its plan dimension but, with the stiff steel layers, lateral expansion is restrained. This restraint induces a bulging pattern as shown in Figure 20.3-A and provides a large increase in stiffness under compressive load. This permits a steel-reinforced elastomeric bearing to support relatively large compressive loads while accommodating large translations and rotations.

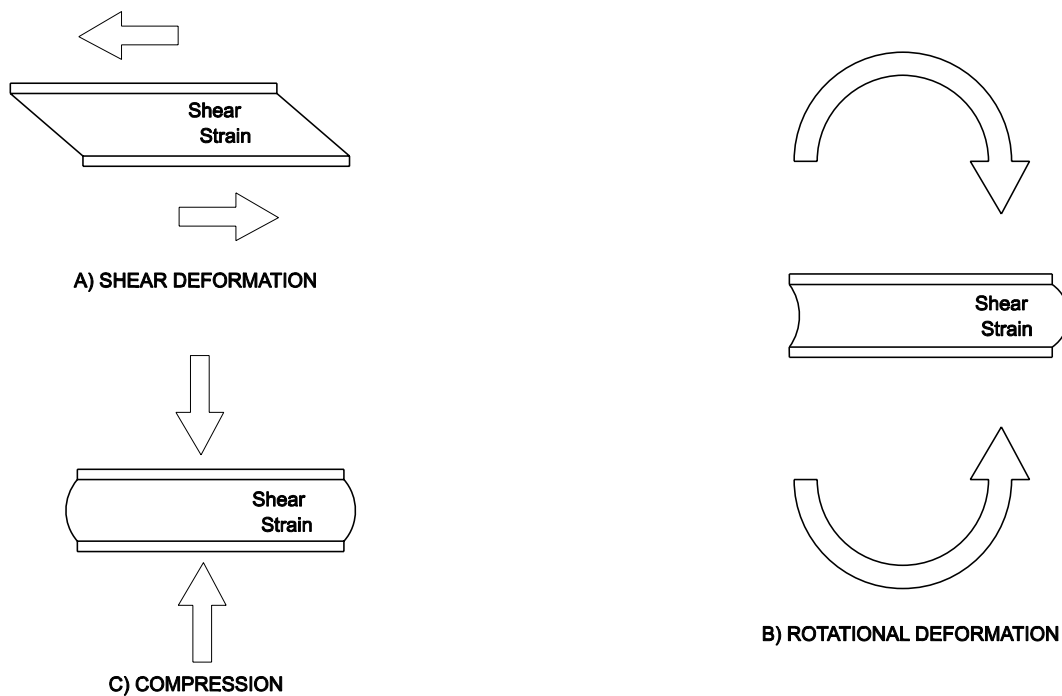

STRAINS IN A STEEL-REINFORCED ELASTOMERIC BEARING

Figure 20.3-A

The design of steel-reinforced elastomeric bearings requires an appropriate balance of compressive, shear and rotational stiffnesses. The shape factor affects the bearing's ability to compress and rotate, but it has no impact on the bearing's ability to translate horizontally.

A bearing must be designed to control the stress in the steel reinforcement and the strain in the elastomer. This is accomplished by controlling the elastomer layer thickness and the shape factor of the bearing. The design must satisfy the fatigue, stability, delamination, yield and rupture of the steel reinforcement; the stiffness of the elastomer; and the geometric constraints.

Large rotations and translations require thicker bearings. Translations and rotations may occur about the longitudinal or transverse axis of a steel-reinforced elastomeric bearing.

Steel-reinforced elastomeric bearings become large if they are designed for loads greater than approximately 650 kips. The maximum practical load capacity of a steel-reinforced elastomeric bearing pad is approximately 750 kips. Uniform heating and curing during vulcanization of such a large mass of elastomer becomes difficult, because elastomers are poor heat conductors. Manufacturing constraints thus impose a practical upper limit on the size of most steel-reinforced elastomeric bearings. If the design loads exceed 650 kips, the designer should check with the manufacturer for availability.

20.3.7 Plain Elastomeric Bearing Pads

Plain elastomeric bearing pads can support modest gravity loads, but they can only accommodate limited rotation or translation. Hence, they are best suited for bridges with small expansion lengths or specialty situations.

Plain elastomeric bearing pads rely on friction at their top and bottom surfaces to restrain bulging due to the Poisson effect. Friction is unreliable, and local slip results in a larger elastomer strain than that which occurs in steel-reinforced elastomeric pads and bearings. The increased elastomer strain limits its load capacity, and the pad must be relatively thin if it will carry the maximum allowable compressive load. A maximum friction coefficient of 0.20 should be used for the design of elastomeric pads that are in contact with clean concrete or steel surfaces. If the shear force is greater than 0.20 of the simultaneously occurring compressive force, then the bearing should be secured against horizontal movement. If the designer is checking the maximum seismic forces that can be transferred to the substructure through the pad, then a friction coefficient of 0.40 should be used.

Plain elastomeric bearing pads shall be designed and detailed in accordance with Method A of LRFD Article 14.7.6.

20.3.8 Design of Steel-Reinforced Elastomeric Bearings

Reference: LRFD Articles 14.7.5 and 14.7.6

The Method A procedure in LRFD Article 14.7.6 shall be used for steel-reinforced elastomeric bearings. The Method B procedure in LRFD Article 14.7.5 may be used for high-capacity bearings, but only with the approval of the Chief Structures Engineer. High-capacity elastomeric bearings should be used only where very tight geometric constraints, extremely high loads, or special conditions or circumstances require the use of higher grade material.

The Method B design procedure allows significantly higher average compressive stresses. These higher allowable stress levels are justified by an additional acceptance test, specifically a

long-duration compression test. Designers must prepare a unique Special Provision for inclusion in the contract documents if a high-capacity elastomeric bearing is used.

Design criteria for both methods are based upon satisfying fatigue, stability, delamination, steel reinforcement yield/rupture and elastomer stiffness requirements.

The minimum elastomeric bearing length or width shall be 6 in. Generally, all pads shall be 50 or 55 durometer hardness. A minimum of $\frac{1}{8}$ in of cover shall be provided at the edges of the steel shims. The top and bottom cover layers shall be no more than 70% of the thickness of the interior layers.

In determining bearing pad thickness, it should be assumed that slippage will not occur. The total elastomer thickness shall be no less than twice the maximum longitudinal or transverse deflection. The designer shall check the bearing against horizontal walking in accordance with LRFD Article 14.7.6.4.

A setting temperature of 70°F shall be used for the installation of the bearings unless the time of construction is known. In this case, the setting temperature may be modified accordingly. NDOT practice is to use 80% of the total movement range for design. This value assumes that the bearing is installed within 30% of the average of the maximum and minimum design temperatures. LRFD Article C14.7.5.3.4 recommends using 65% of the total movement range for design but, due to the wide variation in temperatures across the State and variations within a single day, the design value is increased. The formulas for determining the total elastomer thickness are as follows:

1. For precast, prestressed concrete girder spans, an allowance must be made for half of the shrinkage. Creep is not typically considered when determining the total elastomer thickness for precast concrete girders. The design thermal movement (Δ_T) shall be based upon $T_{MaxDesign}$ and $T_{MinDesign}$ from [Figure 19.1-A](#). Therefore, the minimum total elastomer thickness for precast girders = $2 (\Delta_T + \frac{1}{2} \Delta SH)$.
2. For steel girder spans, the design thermal movement (Δ_T) shall be based upon $T_{MaxDesign}$ and $T_{MinDesign}$ from [Figure 19.1-A](#). No allowance is needed for shrinkage. Therefore, the minimum total elastomer thickness for steel girders = $2 (\Delta_T)$.
3. For cast-in-place and post-tensioned concrete spans, the full shrinkage, elastic shortening and creep shall be considered in addition to the thermal movement. Therefore, the minimum total elastomer thickness = $2 (\Delta_T + \Delta SH + \Delta CR + \Delta EL)$.

The bearing details must be consistent with the design assumptions used in the seismic analysis of the bridge.

20.4 DESIGN EXAMPLE

The following presents a design example for a steel-reinforced elastomeric expansion bearing for a single-span, five-girder steel bridge in Clark County. The example proportions a steel-reinforced elastomeric bearing by selecting the number and thickness of alternating elastomeric and steel layers. Further, the plan dimensions of the bearing are checked.

20.4.1 Given Data

The steel-reinforced elastomeric bearing design example is for an expansion bearing at the abutment of a single-span steel girder:

- Service I Limit State:
 - DL = 78.4 k
 - LL = 92 k
 - P_{sd} = 68 k (factored permanent load at the Strength Limit State considering minimum load factors)
 - WS = 31 k
 - WL = 6 k
 - θ_{sx} = 0.0121 rad (total rotation about transverse axis including 0.005 rad for uncertainty)
- Bridge located in Clark County, $T_{MaxDesign} = 120^{\circ}F$ and $T_{min} = 20^{\circ}F$
- Type II soil profile, $S = 1.2$
- Acceleration coefficient, $A = 0.15$
- Shore A durometer hardness = 50
- $f_y = 36$ ksi (for steel reinforcement)
- Length of Bridge = 120 ft

20.4.2 Trial Bearing Geometry

Exterior or cover thickness $\leq 70\%$ of internal layer thickness (LRFD Article 14.7.6.1)	• Total bearing height:	$h_s = 4.75$ in
	• Length (longitudinal direction):	$L = 15$ in
	• Width (transverse direction):	$W = 15$ in
	• Elastomer exterior thickness:	$h_{re} = 0.25$ in
	• Thickness of interior steel reinforcement:	$t_s = 0.0747$ in (14 gage)
	• Number of shims:	$n_{shims} = 7$
	• Thickness of outermost steel reinforcement:	$t_{p1} = 0.1875$ in

- Thickness of elastomer internal layer = $h_{ri} =$

$$\frac{[4.75 \text{ in} - 2(0.1875 \text{ in}) - 7(0.0747 \text{ in}) - 2(0.25)]}{8} = 0.419 \text{ in}$$

- Total thickness of elastomer = $h_{rt} = 8(0.419) + 2(0.25) = 3.85$ in

See Figure 20.4-A.

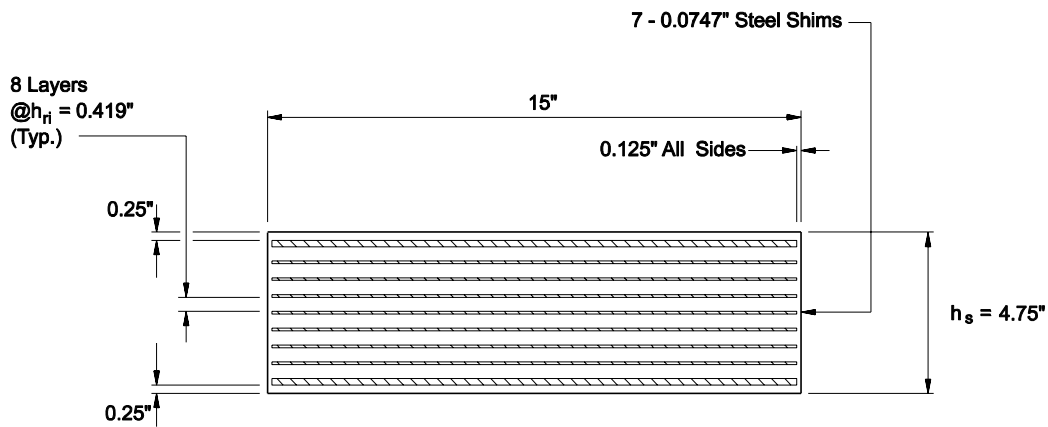

ELASTOMER LAYERS

Figure 20.4-A

20.4.3 Solution

Use Method A for Bearing Design.

Reference: LRFD Article 14.7.6

- Compute Shape Factor

For rectangular bearing without holes:

$$\begin{aligned}
 S &= \frac{\text{Plan Area}}{\text{Area of Perimeter Free to Bulge}} \\
 &= \frac{(15 \text{ in})(15 \text{ in})}{2(h_{ri})(15 + 15)} = \frac{(15)(15)}{2(0.419)(30)} \\
 &= 8.95
 \end{aligned}$$

- Compressive Stress

Allowable stress:

$$\sigma_s \leq 1.0 \text{ ksi} \quad (\text{LRFD Equation 14.7.6.3.2-7})$$

and

$$\sigma_s \leq 1.0 \text{ GS} \quad (\text{LRFD Equation 14.7.6.3.2-6})$$

$$G_{\min} = 0.095 \text{ ksi} \quad (\text{LRFD Table 14.7.6.2-1})$$

$$1.0 G_{\min} S = 1.0 (0.095) (8.95) = 0.85 \text{ ksi}$$

Therefore, $\sigma_s \leq 0.85$ ksi

Average compressive stress:

$$\begin{aligned}\sigma_s &= \frac{DL + LL}{(15 \text{ in})(15 \text{ in})} \\ &= \frac{78.4 + 92 \text{ k}}{225 \text{ in}^2} \\ &= 0.76 \text{ ksi} \leq 0.85 \text{ ksi} \quad \mathbf{OK}\end{aligned}$$

- Compressive Deflection (LRFD Articles 14.7.5.3.3 and 14.7.6.3.3)

Instantaneous deflection:

$$\delta_i = \sum \varepsilon_i h_{ri}$$

For $\sigma_s = 0.76$ and $S = 8.95$

From LRFD Figure C14.7.6.3.3-1: $\varepsilon_i = 0.035$

Dead Load:

For $\sigma_d = 0.35$ and $S = 8.95$

From LRFD Figure C14.7.6.3.3-1: $\varepsilon_i = 0.015$

$$\begin{aligned}\delta_d &= 0.015 [2(0.25) + 8(0.419)] \\ &= 0.06 \text{ in}\end{aligned}$$

Live Load:

For $\sigma_l = 0.41$ and $S = 8.95$

From LRFD Figure C14.7.6.3.3-1: $\varepsilon_i = 0.021$

$$\begin{aligned}\delta_l &= 0.021 [2(0.25) + 8(0.419)] \\ &= 0.08 \text{ in} < 0.125 \text{ in} \quad \mathbf{OK} \quad (\text{LRFD Article C14.7.5.3.3})\end{aligned}$$

Creep:

$$\delta_{\text{creep}} = \text{acr} \delta_d$$

$$\text{acr} = 0.25 \quad (\text{LRFD Table 14.7.6.2-1})$$

$$\begin{aligned}\delta_{\text{creep}} &= (0.25)(0.06) \\ &= 0.015 \text{ in}\end{aligned}$$

Total long-term dead load deflection:

$$\begin{aligned}\delta_{lt} &= \delta_d + \text{acr}\delta_d \\ &= 0.06 + 0.015 \\ &= 0.075 \text{ in}\end{aligned}$$

Initial compressive deflection in any layer at Service Limit State without Dynamic Load Allowance $\leq 0.07 h_{ri}$:

$$\begin{aligned}\delta_{i \text{ one layer}} &= \varepsilon_i h_{ri} \\ &= 0.035 (0.419) \\ &= 0.0147 \text{ in}\end{aligned}$$

$$0.07 (h_{ri}) = 0.07 (0.419) = 0.029$$

Therefore, $\delta_{i \text{ one layer}} = 0.0147 \text{ in} \leq 0.029 \text{ in}$ **OK**

- Shear Deformation

$$h_{rt} \geq 2\Delta_s \quad (\text{LRFD Equation 14.7.6.3.4-1})$$

$$h_{rt} = 3.85 \text{ in}$$

$$\Delta_s = \Delta_o = 0.80 (\Delta_T) + \Delta_{SH} + \Delta_{CR} + \Delta_{EL}$$

$$\Delta_{SH} + \Delta_{CR} + \Delta_{EL} = 0 \quad (\text{Steel bridge})$$

Δ_s is taken as Δ_o , modified to account for the substructure stiffness and construction procedures. Assuming that the abutment does not accommodate any bridge movement and that good construction procedures are followed:

$$\Delta_s = \Delta_o$$

Procedure A for design movements of elastomeric bearings: (LRFD Article 3.12.2.1)

$$\Delta_T = \alpha L (T_{\text{Max Design}} - T_{\text{Min Design}}): \quad (\text{LRFD Equation 3.12.2.3-1})$$

$$\alpha = 6.5 \times 10^{-6} \text{ in/in/}^\circ\text{F} \quad (\text{LRFD Article 6.4.1})$$

$$L = 120 \text{ ft} = 1440 \text{ in}$$

$$\begin{aligned}T_{\text{Max Design}} &= 120^\circ\text{F} \\ T_{\text{Min Design}} &= 20^\circ\text{F}\end{aligned} \quad (\text{Figure 19.1-A})$$

$$\begin{aligned}\Delta_T &= (6.5 \times 10^{-6})(1440)(120 - 20) \\ &= 0.93 \text{ in}\end{aligned}$$

Check for $\Delta_s = 0.80 \Delta_T$

$$h_{rt} \geq 2\Delta_s = 2(0.80)(0.93) = 1.49 \text{ in}$$

$$h_{rt} = 3.85 \text{ in} > 1.49 = 2\Delta_s \quad \mathbf{OK}$$

- Rotation

$$\sigma_s \geq 0.5 \text{ GS} \left(\frac{L}{h_{ri}} \right)^2 \frac{\theta_{sx}}{n} \quad (\text{LRFD Equation 14.7.6.3.5d-1})$$

$$\theta_{sx} = 0.0121 \text{ rad}$$

$$n = 8 + \frac{1}{2} + \frac{1}{2} = 9$$

$$\begin{aligned} 0.5 \text{ GS} \left(\frac{L}{h_{ri}} \right)^2 \frac{\theta_{sx}}{n} \\ = (0.5)(0.095)(8.95) \left(\frac{15}{0.419} \right)^2 \left(\frac{0.0121}{9} \right) \\ = 0.73 \text{ ksi} \end{aligned}$$

$$\sigma_s = 0.76 > 0.73 \text{ ksi} \quad \mathbf{OK}$$

- Stability

$$h_s \leq \text{the lesser of } \frac{L}{3} \text{ or } \frac{W}{3} \quad (\text{LRFD Article 14.7.6.3.6})$$

$$\frac{L}{3} = \frac{15}{3} = 5 \text{ in}$$

$$\frac{W}{3} = \frac{15}{3} = 5 \text{ in}$$

$$h_s = 4.75 \text{ in} < 5 \text{ in} = \frac{L}{3} = \frac{W}{3} \quad \mathbf{OK}$$

- Reinforcement

(LRFD Articles 14.7.5.3.7
and 14.7.6.3.7)

At the Service Limit State:

$$\begin{aligned} h_s &\geq \frac{3 h_{\max} \sigma_s}{f_y} \\ &\geq \frac{3(0.419)(0.76 \text{ ksi})}{36 \text{ ksi}} \end{aligned} \quad (\text{LRFD Equation 14.7.5.3.7-1})$$

$$h_s \geq 0.0265 \text{ in}$$

$$h_s = 0.0747 \text{ in} \geq 0.0265 \text{ in} \quad \mathbf{OK}$$

At the Fatigue Limit State:

$$h_s \geq \frac{2 h_{\max} \sigma_L}{\Delta F_{TH}} \quad (\text{LRFD Equation 14.7.5.3.7-2})$$

$$\geq \frac{2(0.419)(0.41 \text{ ksi})}{24.0 \text{ ksi}} \quad \text{Note: } \Delta F_{TH} = 24.0 \text{ ksi (Fatigue Category A)}$$

$$h_s \geq 0.0143 \text{ in}$$

$$h_s = 0.0747 \text{ in} \geq 0.0143 \text{ in} \quad \text{OK}$$

- Anchorage for Wind

Reference: LRFD Articles 3.8 and 14.8.3.1

Transverse horizontal movement check:

$$\begin{aligned} P_{sd} &= \text{minimum vertical force due to permanent loads} \\ &= 68 \text{ kips} \end{aligned}$$

$$WS = 31 \text{ k}$$

$$WL = 6 \text{ k}$$

Strength III (per bearing):

$$V_{\text{wind}} = \frac{1.4 WS}{5} = 8.7 \text{ k}$$

Strength V (per bearing):

$$V_{\text{wind}} = \frac{0.4 WS + 1.0 WL}{5} = 3.7 \text{ k}$$

Assuming a coefficient of friction of 0.20 (LRFD Article C14.8.3.1):

$$(V_{\text{wind}})_{\max} = 8.7 < 13.6 = 0.20 P_{sd}$$

Therefore, no anchorage is necessary for wind considerations.

- Anchorage for Seismic

Reference: LRFD Article 3.10.9.1

Minimum design connection force = $S \times A \times DL = 1.2 (0.15) (78.4) = 14.1 \text{ kips}$

Because $14.1 \text{ kips} > 0.2 P_{sd} = 13.6 \text{ kips}$, anchorage for seismic forces is required.

Provide anchorage through anchor bolts (assume $\frac{3}{4}$ -in diameter ASTM F1554 anchor rods):

$$R_n = 0.38 A_b F_{ub} N_s = 0.38 \times 0.44 \times 75 \times 2 = 25 \text{ kips} \quad (\text{LRFD Equation 6.13.2.7-2})$$

Assume $\phi = 0.80$ (*LRFD Specifications* does not specify a ϕ for ASTM F1554)

$$\phi R_n = 0.8 \times 25 = 20 \text{ kips}$$

Because 20 kips > 14.1 kips, only one bolt is required; therefore, use four (one at each corner of the bearing)

- Summary

Therefore, the trial bearing geometry shown in [Figure 20.4-A](#) is acceptable for all design requirements.