

NDOT Research Report

Report No. 701-18-803 TO 2 Part 2

TPF-5(358)
**Part 2 - Improving Connectivity: Innovative
Fiber-Reinforced Polymer Structures for
Wildlife, Bicyclists, and/or Pedestrians**

June 2022

**Nevada Department of Transportation
1263 South Stewart Street
Carson City, NV 89712**

Contributing Partners

Alaska DOT

ARC Solutions, Inc.

Arizona DOT

California DOT

Iowa DOT

Ontario Ministry of Transportation

Oregon DOT

Michigan DOT

Minnesota DOT

New Mexico DOT

Parks Canada

Washington DOT



**In Cooperation with
USDOT Federal Highway Administration**

Disclaimer

This work was sponsored by the Nevada Department of Transportation. The contents of this report reflect the views of the authors, who are responsible for the facts and the accuracy of the data presented herein. The contents do not necessarily reflect the official views or policies of the State of Nevada at the time of publication. This report does not constitute a standard, specification, or regulation.

TECHNICAL REPORT DOCUMENTATION PAGE

1. Report No. 701-18-803 TO 2 Part 2	2. Government Accession No.	3. Recipient's Catalog No.	
4. Title and Subtitle Improving Connectivity: Innovative Fiber-Reinforced Polymer Structures for Wildlife, Bicyclists, and/or Pedestrians, Task 9 Report		5. Report Date 25 March 2022	6. Performing Organization Code
7. Author(s) Matthew Bell, Rob Ament, Damon Fick, Marcel Huijser		8. Performing Organization Report No.	
9. Performing Organization Name and Address Western Transportation Institute Montana State University Bozeman, MT		10. Work Unit No.	11. Contract or Grant No.
12. Sponsoring Agency Name and Address Nevada Department of Transportation 1263 South Stewart Street Carson City, NV 89712		13. Type of Report and Period Covered Final Report	14. Sponsoring Agency Code
15. Supplementary Notes			
16. Abstract Expanding on the knowledge gained in Tasks 1-4 of this project, and reported as Task 5, the next tasks, 6-8, are the subject of this Task Report. They focus on the design of an FRP overpass structure and related elements at a specific highway location. A competition to select the design site resulted in six applications; all seeking to have their highway segment selected by the Pooled-Fund Study. All applications were from members of this Pooled Fund Study. The selected site is a section of US Highway 97 (US-97) in Siskiyou County, California. During the summer of 2020, the WTI Research Team conducted a site visit with members of the California Department of Transportation (Caltrans) and other federal and state agency representatives and local stakeholders. Together, the participants evaluated US-97 for the best potential crossing locations for a wildlife overpass. The design site was chosen based on two key criteria; 1) motorist safety and 2) high potential to provide conservation value. The site was also selected to minimize engineering challenges such as span length and cut and fill requirements. Using the selected location on US-97 as a guide, the WTI Team, in partnership with ARC Solutions, hosted a virtual design lab to evaluate the potential use of FRP materials for the wildlife overpass structure and associated wildlife crossing design elements, such as fencing. This virtual lab, actually a series of meetings, leveraged the experience of a diverse group of experts to identify promising applications of FRP materials not only for the US-97 site, but that could be applied to other wildlife crossing projects throughout California and North America. The results of the virtual design lab are being used by ARC to produce a guidebook for implementing FRP materials for wildlife crossing structures. The guidebook was also used to inform the life-cycle costs analysis, which is Task 10 of this project and will be part of the next task report. The objective of this research and development collaboration is a site-specific design of an FRP overpass on US-97 that will be competitively selected and built by Caltrans. This, in turn, will establish a benchmark for the design of other FRP wildlife overpasses in the North American road network.			
17. Key Words Wildlife crossing, fiber reinforced polymers, bridge, wildlife vehicle collision, highway safety, mitigation measure, wildlife overpass, composite materials		18. Distribution Statement No restrictions. This document is available through the: National Technical Information Service Springfield, VA 22161	
19. Security Classifi. (of this report) Unclassified	20. Security Classif. (of this page) Unclassified	21. No. of Pages 61	22. Price

**Improving Connectivity: Innovative Fiber-Reinforced Polymer Structures
for Wildlife, Bicyclists, and/or Pedestrians**

Task 9 Report

by

Matthew Bell, Rob Ament, Damon Fick, and Marcel Huijser
Western Transportation Institute
Montana State University
Bozeman, MT

A report prepared for the
Technical Advisory Committee
Pooled Fund Study TPF-5(358) Task 1
Cost Effective Solutions
Nevada Department of Transportation
Carson City, NV

And

Small Urban, Rural, and Tribal Center on Mobility (SURTCOM)
<http://surtcom.org/>
PO Box 1587
Bozeman, MT

May 5, 2022

TABLE OF CONTENTS

1. Introduction	4
2. Project Tasks.....	6
2.1. Task 6: Site visit and crossing location selection.....	6
2.2. Task 7: Conduct site specific Animal Road Crossing (ARC) design charrette	6
2.3. Task 8: Create a structural design for a wildlife overpass	6
3. US-97 Mitigation Design Location	8
3.1. Site Selection.....	8
3.1.1. Selected Design Location	9
3.2. Field Review US-97 Mitigation Segment and Site Selection	11
3.2.1. Location 1: Grass Lake	12
3.2.2. Location 2: Horsethief Creek.....	13
3.2.3. Location 3: Mud Lake.....	14
3.2.4. Location 4: Grass Lake Summit	16
3.3. Selected Design Site.....	16
4. Virtual Design Lab for FRP Wildlife Infrastructure	18
4.1. Virtual Design Lab Format	18
4.1.1. Participants.....	19
4.2. FRP Virtual Design Lab Categories.....	19
4.3. Preliminary Results of the Virtual Design Lab	20
5. FRP Overpass Design For Grass Lake Summit along US-97	21
5.1. Bridge Geometry	21
5.2. Landscaping Design	23
5.2.1. Surface Aggregates and Vegetation.....	23
5.2.2. Habitat Planting Strategy for Crossing Structure.....	25
5.3. Overpass Structure	27
5.3.1. Overpass Loading	27
5.3.2. FRP Superstructure	29
5.3.3. Sound and light barriers	31
5.4. Wildlife Fencing and Supporting Elements	33
6. Conclusion.....	35
7. References	36

8.	Appendix A: Proposed Design Locations	38
8.1.	Submitted Design Sites	38
8.1.1.	USA Parkway/State Road 439 in Storey County, Nevada	38
8.1.2.	State Road 139 in Modoc County, California.....	39
8.1.3.	State Road 20 in Colusa County, California.....	40
8.1.4.	U.S. Highway 101 in Humboldt County, California	42
8.1.5.	State Road 126 in Ventura County, California	43
8.2.	Additional Photos for the US-97 Site Visit.....	44
8.2.1.	Site 1: Grass Lake	44
8.2.2.	Site 2: Horsethief Creek.....	48
8.2.3.	Site 3: Mud Lake.....	50
8.2.4.	Site 4: Grass Lake Summit	54
9.	Appendix B: Summary of Preliminary Virtual Design Lab Results	57
9.1.	FRP Wildlife Infrastructure Elements.....	57
9.1.1.	Substructure: Footings	57
9.1.2.	Substructure: Abutments.....	57
9.1.3.	Superstructure: CT Girders.....	57
9.1.4.	Superstructure: Deck.....	58
9.1.5.	Superstructure: Aesthetics	58
9.1.6.	Corridor: Fencing and Jump-outs	59
9.1.7.	Corridor: Sound and Light Barriers	59
9.2.	Environmental Landscaping.....	59
9.2.1.	Environmental Parameters	60
9.2.2.	Surface and Approach: Substrate & Fill	60
9.2.3.	Surface and Approach: Landscape Materials	60

LIST OF TABLES

Table 1: Summary of the six proposed mitigation sites submitted by the TAC.	8
Table 2: Design site location rankings used to assist in the decision-making process.	9
Table 3: Value matrix for the US-97 FRP design site locations.	17
Table 4: A short list of native species that could be used to reclaim US-97 wildlife overpass site that are present in adjacent habitats.	24
Table 5: Design Load Summary	28

LIST OF FIGURES

Figure 1: Proposed US-97 mitigation location in Siskiyou County, California.	10
Figure 2: Collared elk GPS locations and WVC density along the US-97 mitigation area 2015-2019.....	11
Figure 3: Four locations (bright red numbers) along US Highway 97 identified as potential sites for a FRP wildlife overpass design in Siskiyou County, California.	12
Figure 4: The Grass Lake mitigation location looking east.....	13
Figure 5: Horsethief Creek mitigation site looking east.	14
Figure 6: Mud Lake A site looking north.	15
Figure 7: Mud Lake B mitigation site looking southeast.....	15
Figure 8: Grass Lake Summit mitigation site looking south-southwest.	16
Figure 9: Elevation view of the US-97 wildlife overpass.....	22
Figure 10: Plan view with dimensions of the US-97 wildlife overpass.....	22
Figure 11: Aerial representation of the US-97 FRP wildlife overpass footprint.	23
Figure 12: Planting strategy with clear path of visibility through the center of the structure.	26
Figure 13: The CT girder bridge system. (a) Left, a cross section of the CT girder showing the foam cores and (b) right, installed CT girders during first construction in Hampden, Maine, 2020.....	30
Figure 14: Cross section of the preliminary design for the CT girder from AIT Bridges.	30
Figure 15: Cross section of the wildlife overpass showing the layout of the girders, concrete deck, soil, drainage, and barriers on the bridge span.....	31
Figure 16: Recycled-plastic sound and light barrier installed on top of soil-retaining concrete curb.	32
Figure 17: Representation of recycled-plastic posts for use in wildlife fencing, gates, and jump-outs.....	33
Figure 18: Rendering of US-97 FRP wildlife overpass with Mt. Shasta in the background.....	35
Figure 19: Proposed design site location for SR-439 in Storey County, Nevada.....	38
Figure 20: Proposed site location for SR-139 in Modoc County, California.	39
Figure 21: Mule deer crossing SR-139 during the winter months.....	40
Figure 22: GPS data of collared elk along the proposed SR-20 mitigation site.	41
Figure 23: Proposed mitigation location along US-101 in Humboldt County, California.	42
Figure 24: Proposed mitigation location along SR-126 in Ventura County, California.....	43
Figure 25: Grass Lake A potential site looking west.....	44

Figure 26: The area north of Grass Lake A potential site that will require backfill to create the approach ramps for the wildlife overpass.	45
Figure 27: Standing south of US-97 on Grass Lake B looking west towards Grass Lake A.	45
Figure 28: Standing south of US-97 on Grass Lake B looking east-northeast towards the blind curve.....	46
Figure 29: Grass Lake B looking south towards US-97 showing the little fill required for the approach ramps.	46
Figure 30: The railroad tracks south of US-97 at Grass Lake B proposed site.	47
Figure 31: Standing south of US-97 on top of the embankment at the proposed Horsethief Creek site, looking east-northeast.....	48
Figure 32: Horsethief Creek site showing the change in elevation topography south of US-97..	48
Figure 33: North of US-97 at Horsethief Creek proposed site looking east-southeast.....	49
Figure 34: Looking south over US-97 at Horsethief Creek proposed mitigation site.	49
Figure 35: The downhill, below grade, elevation change at the Horsethief Creek site looking east.	50
Figure 36: Mud Lake A proposed site looking west-southwest along US-97.....	50
Figure 37: Mud Lake A looking northwest over US-97.....	51
Figure 38: Habitat at Mud Lake A looking south-southwest.....	51
Figure 39: Standing on the embankment west of US-97 at the Mud Lake B site looking north..	52
Figure 40: Overlooking US-97 at the Mud Lake B proposed site looking east.....	52
Figure 41: Below grade road alignment at Mud Lake B looking south-southwest.	53
Figure 42: Below grade road alignment at Mud Lake B looking north-northwest.....	53
Figure 43: Grass Lake Summit proposed site looking south towards Mt. Shasta.	54
Figure 44: Standing on embankment at Grass Lake Summit site looking east over US-97.....	54
Figure 45: Grass Lake Summit site looking north-northeast along US-97.....	55
Figure 46: Highest elevation point at Grass Lake Summit site looking south-southwest along US.97.	55
Figure 47: Standing on eastern embankment at the Grass Lake Summit site looking north over US-97.....	56

1. INTRODUCTION

In the United States, it is estimated that there are one to two million wildlife-vehicle collisions (WVCs) with large animals annually (Huijser *et al.* 2007; Sullivan 2011). The cost to society is billions of dollars, as well as tens of thousands human injuries and hundreds of fatalities. There are currently over 20 various types of WVC mitigation measures that can reduce collisions with wildlife, some are highly effective, others are not (Huijser *et al.* 2021). Crossing structures – overpasses and underpasses - combined with fences, when properly designed, are proven, highly effective mitigation measures (Huijser *et al.* 2009, Rytwinski *et al.* 2016). They can significantly reduce WVCs with large animals, increase motorist safety, and maintain ecological connectivity for many types and sizes of wildlife species (Sawyer *et al.* 2016, Ford *et al.* 2017).

Overpass structures, much like vehicular bridges, have been designed by engineers using pre-cast or cast-in-place concrete, steel, or a mix of the two materials, designed as an arch or beam and slab structure. Research on materials and structural designs for wildlife crossings has been limited and suggests little innovation has been explored (Lister *et al.* 2015). Given wildlife crossing structures are such successful highway mitigation strategies for human safety and wildlife conservation, the exploration of advanced materials and techniques is merited.

This research project explores the promising application of fiber-reinforced polymers (FRPs) to wildlife crossing structures and related design elements. If FRP crossing designs can meet the bridge specifications set by transportation agencies and prove to have less expensive life cycles, they will provide a new alternative for engineers. Particularly if they prove to be more efficient, quickly deployed, more durable, and require less maintenance than structures that rely on traditional materials.

The Task 5 Report for this project documented Tasks 1-4. These tasks investigated the material properties of FRP, the applications to bridge structures, and the promising features for other wildlife crossing infrastructure elements (Bell et al. 2020a). The Task 5 Report highlighted the versatility of FRP materials and their beneficial outcomes when compared with traditional bridge construction using concrete and steel materials. FRP structures are capable of meeting bridge design specifications and can potentially result in lower life cycle costs. FRP materials can provide a new approach to building wildlife crossings that are more efficient in construction, require less maintenance, and ultimately are more adaptable than traditional materials (Bell et al. 2020b).

This Task 9 Report documents tasks 6 through 8 and builds on the knowledge gained from the earlier tasks. The Task 9 Report focuses on the design of a wildlife crossing overpass using FRP infrastructure for a specific site. The site selected has a demonstrable need to minimize WVCs and improve landscape connectivity. The tasks in this report explore opportunities for inclusion of FRP materials as potential design elements in wildlife crossing infrastructure at the selected site. By working with the California Department of Transportation (Caltrans) personnel and professionals from other local and federal agencies, the WTI Research Team (WTI Team) was able to address challenges and identify solutions to incorporate this new technology into a wildlife crossing design. Furthermore, this report explores new potential uses of FRP materials beyond existing applications.

This project's use of an existing highway segment with elevated WVC rates, that also serves as a potential barrier or partial barrier to wildlife movement, provides an opportunity to demonstrate the potential for using FRP materials in wildlife overpass designs. A team of ecologists, engineers, planners, wildlife biologists, and landscape architects have worked together to explore, identify, and evaluate a variety of applications of existing commercially available FRP materials; ones that can be used at the project site and elsewhere across the North American road network. Although there are countless uses of the FRP materials in this report, this project selected and focused on those applications relevant to the design of a wildlife overpass crossing structures.

2. PROJECT TASKS

The three tasks in this Task 9 Report are, 1) visit the selected highway segment requiring mitigation, and work with local agency experts to identify the best site for the design of an FRP wildlife overpass; 2) collaborate with a team of interdisciplinary professionals to investigate different applications of FRP materials for the wildlife overpass infrastructure at the site and for broader applications in other geographies; and, 3) create design criteria and a preliminary structural design of a specific wildlife overpass and its associated design elements using FRP materials for the selected location in California.

This Task 9 Report documents the specific activities of Tasks 6-8 and their outcomes. A summary of these tasks follows.

2.1. Task 6: Site visit and crossing location selection

The WTI Team collaborated with the host agency, Caltrans, to develop a site-specific wildlife crossing using a FRP overpass structure that incorporates FRP materials into related crossing design elements. On July 9, 2020, the WTI Team, Caltrans employees and other specialists from federal, state and local agencies visited the US Highway 97 (US-97) segment to select the best site. The field review sought to identify the location with the least design limitations related to the overpass structure's foundations, span, width, and approach geometry. Access to the site was also reviewed to ensure efficient construction practices can be used. Similarly, working with Caltrans, the WTI team collected relevant available information on wildlife use, soil properties, geotechnical challenges, native plant materials and other pertinent design information.

2.2. Task 7: Conduct site specific Animal Road Crossing (ARC) design charrette

A design charrette for the US-97 overpass was originally intended to be a two day in-person event held near the design location in cooperation with the host agency in September 2020. Due to the COVID-19 pandemic, the design format was changed to a virtual design lab. The WTI Team cooperated with ARC Solutions staff and Caltrans to create a virtual workshop format that engaged both local agencies and North American experts to identify the best applications of FRP materials for wildlife crossings. This virtual design lab explored the suitability of the bridge systems identified in Task 4. It also allowed for the WTI Team to gather information specific to the overpass crossing site and establish working relationships with local experts. Ultimately, the goal was to incorporate local concerns, ecological knowledge, engineering expertise and sensitivities into the structural designs in Task 8, with specific recommendations for the design location selected in Task 6.

2.3. Task 8: Create a structural design for a wildlife overpass

Information obtained from the literature, FRP manufacturer review, the site visit, and the virtual design lab were used to create a prototype design for the FRP wildlife overpass at the selected US-97 wildlife crossing site. The main components of the wildlife overpass design include: 1) superstructure and decking, 2) sound and light barriers, 3) fencing and jump-outs (breaks in the fence with ramps to provide wildlife egress when trapped on the highway side of the fencing), 4)

landscaping, and 5) additional design recommendations for the US-97 site to ensure an effective wildlife crossing is constructed.

As part of the structural design process, there are two different goals being completed by the participating groups. First, the WTI Team worked with Caltrans and the manufacturer of the selected FRP material — Advanced Infrastructure Solutions (AIT) — to explore design options, identify pathways for this research project’s design to result in a FRP structure capable of being constructed by Caltrans. Second, the WTI Team and ARC Solutions staff conducted the virtual design lab that served to create a design guide. As part of the process, the guidelines will contain recommendations on which design elements can use FRP materials at the US-97 site, those that could be used in other North American locations, and which design elements may require further research and development. Parallel, and independent of this project, Caltrans personnel are developing design load specifications for their agency for future designs of FRP materials in wildlife crossings.

The designs presented in this report by the WTI Team are an application of existing, commercially available FRP materials for wildlife crossing infrastructure that can be approved and built along the North American road network. The application of FRP materials was also incorporated into various design elements other than the bridge infrastructure, but only when the WTI Team, through consultation with transportation agency personnel and other experts, anticipated they would require minimal departure from existing transportation agency practices.

3. US-97 MITIGATION DESIGN LOCATION

3.1. Site Selection

The WTI Team developed a competitive process, in cooperation with the Pooled Fund Study TPF-5(358) Task 1's Technical Advisory Committee (TAC) to select a highway site for the Project's FRP wildlife overpass design. A request for applications was developed, along with a set of preferred criteria, for the participating agencies in the pooled fund study to submit a site proposal. The 12 TAC members were asked to reach out to personnel in their state or provincial transportation agency, or Parks Canada Agency, to identify highway segments that would benefit from a future wildlife overpass.

The goal was to have local agency staff champion the selected site and help the WTI Team acquire the necessary site-specific information for the design. Collaboration with agency bridge engineers and planners willing to share their agency's bridge design, specifications, and construction practices was necessary to achieve a viable FRP wildlife overpass design. The preferred attributes for the location for an FRP wildlife overpass design included the following:

- The site be a priority that the agency is already planning to address.
- Committed sponsoring agency to invest in WVC mitigation at the site.
- Two-lane road to keep the demonstration FRP project to a reasonable scale.
- Few topographical, hydrologic, or edaphic design challenges.
- High-profile site that with traveling public exposure.
- Prioritized for wildlife rather than livestock.

Six proposed design locations were submitted for consideration: one in Nevada and five in California. A brief overview in Table 1 summarizes road segment attributes for each of the proposed locations in relation to the site selection criteria. For more details about the proposed design locations, see Appendix A: Proposed Design Locations.

Table 1: Summary of the six proposed mitigation sites submitted by the TAC.

Road	County, State	Mitigation Plans	# of Lanes	Mitigation Length	Traffic Exposure	Roadway Topography	Target Species
SR-439	Storey, NV	Identified	4	TBD	High	Below grade	Horse
SR-139	Modoc, CA	Yes	2	10 mi	Low	Flat	Mule deer
US-97	Siskiyou, CA	Identified	2	10-20 mi	3600-9000 AADT	Hills and flat	Elk, deer, pronghorn
SR-20	Colusa, CA	Proposed	2	4 mi	Peak 870 vehicles/hour	Hills and flat	Elk
US-101	Humboldt, CA	Priority	2	3-5 mi	4000 AADT	Flat	Elk, deer, bear
SR-126	Ventura, CA	Identified	4	26 mi	26000 AADT	Hills and flat	Deer, cougar, bear

NOTE: TBD = To be determined, Mi = mile; AADT = Average annual daily traffic

Table 2 was created to rank each location based on the goals of the project. These are subjective rankings based on the information provided in the proposals about the highway segments proposed for mitigation and from agency reports related to the highway and its surrounding area of interest. The WTI Team gave their recommendation, then a vote by the TAC to select the site was held. The highway segment receiving the most votes was selected as the location for the site-specific FRP overpass design.

Table 2: Design site location rankings used to assist in the decision-making process.

Road	County, State	Local Conservation Value	Regional Conservation Value	Highway Mortality	Highway Barrier	Land Use Security	Mitigation Options	Average Value
SR-439	Storey, NV	4	2	5	2	2	1	2.7
SR-139	Modoc, CA	4	3	4	2	5	5	3.8
US-97	Siskiyou, CA	4	5	4	3	4	4	4.0
SR-20	Colusa, CA	5	4	3	5	4	3	4.0
US-101	Humboldt, CA	5	3	5	2	5	2	3.7
SR-126	Ventura, CA	4	5	3	4	2	1	3.2

Note: Higher numbers are a better score; each value is from 0-5.

3.1.1. Selected Design Location

The design location selected was US Highway 97 (US-97) in Siskiyou County, California (Figure 1). This section of road is a conventional two-lane highway with one section having a third lane for uphill traffic on the steeper grades. Passenger vehicles are the primary user group. Annual average daily traffic (AADT) averages approximately 6,300 vehicles a day. According to traffic demand models, AADT growth is projected to increase five percent per year over the next several years. Additionally, bicyclists use the roadway shoulders, as there are no sidewalks or bike lanes or adjacent bicycle-pedestrian paths along this route. US-97 is the second most highly used road in Siskiyou County for agricultural and timber product freight and is a popular alternative to Interstate 5 (I-5) because there are fewer steep grades that are difficult for heavily laden freight vehicles. US-97 is also used as an alternative route when I-5 is closed during winter storms.

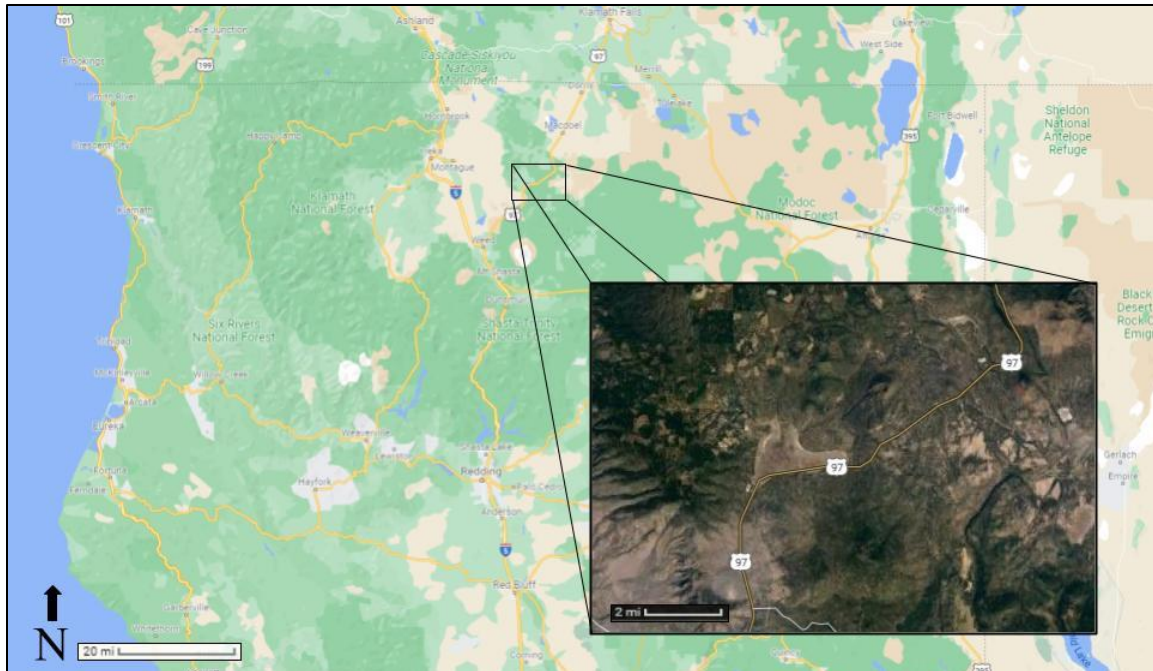

Figure 1: Proposed US-97 mitigation location in Siskiyou County, California.

Caltrans, District 2, identified this section of US-97 as bisecting a priority wildlife corridor and recognized as an essential ecological connectivity area. It also is in the top five percentile for deer-vehicle collision density in recent reports for the entire state of California. (Huijser and Begley, 2019)

Based on five years of GPS wildlife collar data obtained by the California Department of Fish and Wildlife (CDFW), it was revealed that elk (*Cervus canadensis*) approach the roadway and frequently do not cross (Figure 2). The collar data also identified areas where elk are more likely to cross. The regular movement of large ungulates - elk, mule deer (*Odocoileus hemionus*) and pronghorn antelope (*Antilocapra americana*) - across the roadway create a motorist safety concern in the proposed mitigation segment of US-97. Caltrans maintenance staff remove 6-7 wildlife carcasses a month from this section of US-97 (Personal communication. Wesley Stroud, Caltrans, 2021). Although wildlife-vehicle collisions (WVCs) are documented along the entire route in the US-97 proposed mitigation segment, there are multiple locations along the road where collisions are more frequent, often referred to as “hot spots”.

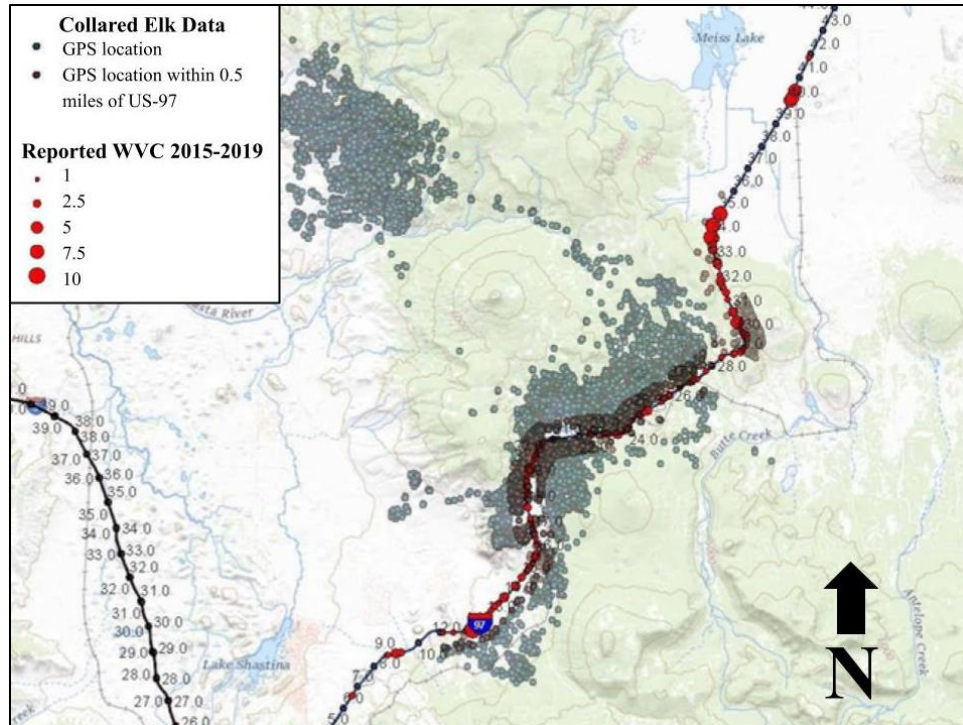

Figure 2: Collared elk GPS locations and WVC density along the US-97 mitigation area 2015-2019.

The high rate of WVCs has led to a heightened concern for public safety and wildlife conservation in this area. As a result, Caltrans and numerous collaborating stakeholders (Siskiyou County Board of Supervisors, the United States Forest Service’s Klamath National Forest [USFS-KNF], California Deer Association [CDA], California Highway Patrol [CHP], Rocky Mountain Elk Foundation [RMEF], CDFW, Ore-Cal Resource Conservation and Development Area Council [Ore-Cal RC&D], University of California Davis Road Ecology Center, Fruit Growers Supply Company, and other private landowners) have formed the “State Route 97 Strike Prevention Team” to discuss viable options to reduce WVCs, restore elk/deer migratory corridors, and increase roadway permeability for all wildlife.

3.2. Field Review US-97 Mitigation Segment and Site Selection

Caltrans and CDFW identified six sites, at four locations along US-97 mitigation area that are potentially suitable for a wildlife overpass structure (Figure 3). In July 2020, the WTI Team visited the US-97 location to investigate the potential sites with Caltrans, CDFW, and other local stakeholders. Site visits allowed experts to evaluate both roadway and landscape characteristics. The different characteristics at each site influenced which FRP bridge solutions were possible for each location. All aspects of the wildlife crossing’s design elements (*e.g.*, overpass structure, fencing, jump-outs) were considered during the site evaluations to ensure the selected mitigation site would most effectively improve motorist safety, increase landscape permeability, and restore wildlife migratory corridors as well as local species movement.



Figure 3: Four locations (bright red numbers) along US Highway 97 identified as potential sites for a FRP wildlife overpass design in Siskiyou County, California.

Note: 1) Grass Lake; 2) Horsethief Creek; 3) Mud Lake; 4) Grass Lake Summit

Topography varies along the US-97 segment, from a mountain pass to wet lakeside habitat. The Grass Lake and Mud Lake areas had two potential sites that were near one another (hundreds of meters apart). Thus, they have the same site name, but are distinguished from one another by either an A or B designation.

3.2.1. Location 1: Grass Lake

The Grass Lake site (Site 1 in Figure 3) consists of two locations about 100 meters (m) (328 feet [ft]) apart. In Figure 4, the photo was taken standing on top of Grass Lake 1-A, and is directed towards Grass Lake 1-B. They are both on a level, below grade two-lane road with a right-of-way embankment approximately 3 m (10 ft) in elevation at Site 1-A, and 4.5 m (15 ft) at Site 1-B. North and south of the highway is National Forest land, but about 100 m (328 ft) south of the road there is a below-grade railroad track that is parallel to the highway. This could cause issues for the flow of wildlife movement. There are access roads near this location that are used by the public and the railroad company. These roads will need to remain open, as they provide access points for the public and railroad employees, which could potentially disturb wildlife approaching the crossing site. This site would require gates and cattleguards for the wildlife fencing that directs animals to the crossing and prevents them from entering the roadway.



Figure 4: The Grass Lake mitigation location looking east.

The Grass Lake area is known to support elk and deer movements and is part of the migration route for at least one elk herd. Not unexpectedly, the Grass Lake sites have high levels of WVCs. The Grass Lake 1-B site would be the best option for a wildlife crossing, compared to the 1-A site, due to engineering considerations. The I-B site has 4.5 m (15 ft) high embankments on either side of the road and would require minimal fill for the approach grade. Grass Lake 1-A would require a large amount of fill for the approach to the overpass structure resulting in a more costly design.

3.2.2. Location 2: Horsethief Creek

The second potential site is a two-lane section of US-97 that is below-grade and has an elevation change of approximately 30 m (100 ft) from the top of the hill to the bottom where the road crosses over Horsethief Creek (Figure 5). The change in elevation causes the right-of-way embankments to change in height from 1-6 m (3-20 ft) as the road heads west. The high embankment makes it suitable for an overpass because it would require minimal backfill to build up the approaches. However, there is a gravel road on the north side of US-97 at the start of the Horsethief Creek site that allows public access to National Forest land.

The WVCs in this area are the lowest compared to the other potential sites. There are very few elk carcasses picked up near here, but deer and other smaller mammals are common picked up. This site is part of the mule deer migration route and provide a connection between protected habitat for multiple species, including black bears (*Ursus americanus*).



Figure 5: Horsethief Creek mitigation site looking east.

3.2.3. Location 3: Mud Lake

The Mud Lake location (Site 3 in Figure 3) also consists of two potential sites for a wildlife overpass, and they are located about one-half mile apart from each other. Mud Lake A is the most northern site within the US-97 mitigation segment. It is a two-lane, at-grade road that is in the transition zone between forest and grassland habitat (Figure 6). The flatness of the area would require the most fill, of all the sites visited for this project, to create approach ramps to an overpass. This area supports local deer movement and pronghorn antelope are more common here than at the other sites. The Mud Lake A site provides a connection between habitat types for multiple species. The Mud Lake A site has private land on both sides of the highway and would require a conservation easement for the long-term security of wildlife movement if an overpass was constructed.



Figure 6: Mud Lake A site looking north.

The Mud Lake B site is south of the Mud Lake A site on US-97 and is within National Forest land boundaries. It is in a forested area just beyond the grassland transition zone (Figure 7). It is a below grade, two-lane road that traverses the bottom of a hillside. This makes the right-of-way embankment higher on the north side of the road; about 4.5 m (15 ft) on the north side and 3 m (10 ft) on the south. The site supports local deer movement with occasional pronghorn antelope occurring near the road.



Figure 7: Mud Lake B mitigation site looking southeast.

3.2.4. Location 4: Grass Lake Summit

Grass Lake Summit is the most southern of the potential sites in the US-97 mitigation area. At this site the highway is below grade, contains three lanes, and its adjacent embankments are approximately 3.6 m (12 ft) in height (Figure 8). The road traverses a small ridgeline and is located at the highest elevation point at 1,555 m (5,101 ft) within the US-97 mitigation area. Grass Lake Summit is along an established elk and deer migration route as the animals move between their summer and winter ranges. This site has the second most WVCs out of the six potential sites visited in the field review. The land west of the road is owned by the Fruit Growers Supply Company and would require a conservation easement for long-term land use security.



Figure 8: Grass Lake Summit mitigation site looking south-southwest.

3.3. Selected Design Site

After visiting the site, meeting with local stakeholders, and collecting additional relevant data for the US-97 segment, a value matrix was created to contrast and compare each of the six sites visited by the WTI Team, Caltrans employees and other experts. At each site the group agreed upon the numerical value in each cell of the matrix (Table 3) to serve as a guide in the decision-making process for site selection. Using this guide, the Grass Lake Summit site was selected as the most desirable for the design location for an FRP wildlife overpass. This recommendation was based on the following rationale:

- Grass Lake Summit has the highest conservation value of any of the six sites evaluated.
- Grass Lake Summit had the highest value for addressing WVCs of any of the six sites evaluated.
- There were no identified issues for design and permitting, nor insurmountable conflict issues with landowners or adjacent railway operations.
- Grass Lake Summit supports the most local and migratory movements of elk and deer.

After reviewing the six sites, and evaluating the various safety, conservation and design criteria, the Grass Lake Summit site emerged as the best location for the FRP crossing design (Table 3). If the crossing structure is designed with adequate fencing and other design elements, it can also effectively reduce WVCs for an extended portion of this section of US-97.

Table 3: Value matrix for the US-97 FRP design site locations.

Values for Prioritization	US-97 Potential Crossing Sites					
	Grass Lake Summit	Grass Lake (A)	Grass Lake (B)	Horse Thief Creek	Mud Lake (A)	Mud Lake (B)
Safety Criteria						
High EVCs	4	1	1	0	1	1
High DVCs	4	3	3	2	5	5
High WVCs (includes all species)	4	3	3	2	5	5
Safety Values Subtotal	12	7	7	4	11	11
Conservation Criteria						
Elk Migration Route	4	3	2	1	0	0
Mule Deer Migration Route	2	0	0	5	0	0
Supports local deer movement	3	2	2	4	4	4
Supports local elk movement	5	3	3	1	0	0
Connects habitat for multiple spp.	3	3	3	4	4	4
Multiple elk herd use/connectivity	1	1	1	0	0	0
Adjacent conservation improvements	4	3	4	4	4	3
Conservation Values Subtotal	22	15	15	19	12	11
Design and Management Issues						
Archaeological restrictions	4	5	5	5	5	5
Livestock fencing not wildlife friendly	3	3	3	3	3	3
Adjacent railway & ROW management	4	2	3	5	5	5
Wetlands	3	3	3	4	5	5
Adjacent land security (managed for conservation)	3	3	4	5	5	5
Engineering difficulties	3	3	5	5	4	2
Cattle crossing considerations	3	3	3	3	3	3
Adjacent use conflict (i.e., rest stop, access road)	2	2	1	4	4	3
Design and Management Subtotal	25	24	27	34	34	31
Total Value	59	46	49	57	57	53

Note: Higher numbers are a better score; each value is from 0-5.

4. VIRTUAL DESIGN LAB FOR FRP WILDLIFE INFRASTRUCTURE

For this task, the WTI Team worked in collaboration with the staff of ARC Solutions to convene and host a virtual meeting of experts to discuss potential applications of FRP materials in wildlife crossings. This design component of the Project leverages the experience of a diverse group of professionals to identify potential applications of existing FRP materials in wildlife crossing designs elements, and their likely application at the US-97 site as well as in future FRP crossing projects in North America.

Preceding this project, the first collaborative laboratory (CoLab) was co-hosted by the University of Ryerson's Ecological Design Lab and the Western Transportation Institute in Bozeman, Montana, in 2018. It identified the potential benefits that could be realized by FRP integration into green infrastructure and wildlife crossings and provided a foundation for further exploration of FRP materials in overpass designs for the US-97 site in California.

Modeled after the 2018 CoLab, the original CoLab proposed for this project was to have been an in-person meeting to facilitate interdisciplinary collaboration focused on the integration of expertise from different fields of academic research and agency expertise to solve complex challenges that are outside the realm of any singular discipline. Due to the COVID-19 pandemic and the inability to meet in-person, the CoLab was changed to a virtual design lab (VDL). The goals, methods, and outcomes from this working group are described below. A summary of the outcomes of the design lab can be found in Appendix B: Summary of Preliminary Virtual Design Lab Results. The guidebook from the VDL will be finalized and available in the second quarter of 2022.

4.1. Virtual Design Lab Format

A small working group of experts in wildlife crossings - engineers, landscape architects, and wildlife ecologists - were convened to discuss the potential integration and design of FRP materials in various wildlife crossing elements, other than the bridge infrastructure. A desired outcome was to generate a FRP design guidebook for wildlife crossings that would subsequently be further developed by ARC Solutions. The guidebook will 1) provide Caltrans with site-specific uses of FRP materials that would help ensure a buildable, effective, and context-sensitive design for the site along US-97; and 2) identify and evaluate opportunities for general integration of FRP materials into various design elements for future FRP wildlife crossing infrastructure in other locales across North America.

Three discussions with workshop participants were hosted on Zoom™, with additional electronic communication and correspondence supported throughout the planning and design process. For the three key discussions, participants collaborated in real time using Google Jamboard™. Google Jamboard™ is a collaborative interface used to facilitate online workshop participation. It can be thought of as a shared virtual whiteboard that allows the group to collaboratively record, share, and organize comments in real-time.

4.1.1. Participants

An interdisciplinary team of wildlife crossing experts was convened by ARC Solutions, with the guidance of Caltrans, to identify key individuals and stakeholders to involve in the decision-making process for the US-97 crossing site.

4.1.1.1. Engineering Working Group Participants

- Robert Ament, Western Transportation Institute - Montana State University (WTI)
- Matthew Bell, Research Engineer, WTI
- Marta Brocki, Associate Director, ARC Solutions
- Renee Callahan, Executive Director, ARC Solutions
- Damon Fick, Structural Engineer, Assistant Professor, Montana State University
- Manode Kodsuntie, Bridge Design, Caltrans
- Heidi Kuntz, Structure Maintenance Investigations Senior, Caltrans
- Terry McGuire, Professional Engineer, Consultant, Parks Canada Agency (ret.)
- Robert Rock, Principal and Landscape Architect, Living Habitats
- Ryan Stiltz, Technical Liaison Engineer, Caltrans

4.1.1.2. Landscape Working Group Participants

- Robert Ament, Road Ecology Program Manager, WTI
- Matthew Bell, Research Engineer, WTI
- Marta Brocki, Associate Director, ARC Solutions
- Renee Callahan, Executive Director, ARC Solutions
- Marcel Huijser, Wildlife Ecologist, WTI
- Sandra Jacobson, Wildlife Biologist, United States Forest Service (retired)
- Richard Lis, Senior Environmental Specialist, California Department of Fish and Wildlife
- Nina-Marie Lister, Professor, Ryerson University; Director, Ecological Design Lab
- Robert Rock, Principal and Landscape Architect, Living Habitats
- Eric Rulison, Biologist, Caltrans
- Robin Solari, Landscape Architect, Caltrans

4.2. FRP Virtual Design Lab Categories

The exploration of potential uses of FRP materials that were evaluated during the VDL were divided into three categories: basic, enhanced, and innovative. Below is a summary of these categories and the FRP wildlife infrastructure elements were placed in. These groups made it easier to identify applicable solutions and areas where more research is required.

Basic: Solutions identified within this category include FRP applications that are developed, tested, and can be implemented along the North American road network. They are a readily available technology that use conventional construction methods and require minimal departure from existing agency practices.

Enhanced: This category includes modifications to the wildlife crossing design that provide opportunities to integrate FRP in novel ways that leverage and demonstrate the material's positive qualities, enhance the ecological and structural function of the crossing, or provide ancillary benefits in the form of interpretive components. These applications may require additional agency approval or veer from traditional construction methods.

Innovative: Applications of FRP categorized as innovative require additional research prior to their integration into a wildlife crossing design. They have been identified as needing further investigation based on their potential to deliver benefits in structural design, feasibility, sustainability, or ecological function.

4.3. Preliminary Results of the Virtual Design Lab

The FRP guideline document that summarizes the design recommendations for the various applications of FRP materials for wildlife crossings will be available at a later date, upon its completion by ARC Solutions. The guidelines will be incorporated into this project's final report. For this Task 9 Report, preliminary results from the VDL are described in Appendix B.

5. FRP OVERPASS DESIGN FOR GRASS LAKE SUMMIT ALONG US-97

Based on information gathered from the previous tasks, the experience of Caltrans personnel and the selected FRP manufacturer, the WTI Team relied on a wide variety of information to design the FRP overpass at the selected Grass Lake Summit site on US-97. The preliminary design includes FRP bridge members and related wildlife crossing design elements (*e.g.*, fence, sound/light barrier, jump-out, etc.) required to make an effective and safe wildlife crossing. The purpose of the preliminary designs of these FRP components is to provide a resource for the successful planning and completion of wildlife overpass with minimal departure from established construction methods and the bridge approval process. The improvements and comments are based on the preliminary mitigation site plans provided by Caltrans and in no way reflect a completed or approved design.

The primary objective for the US-97 site is to reduce the high number of WVCs. The majority of WVCs in the Grass Lake Summit area are with elk or deer and are the focal species for the overpass. Thus, design considerations (*e.g.*, the percent slope of the approach to the crossing structure, fencing) were prioritized to facilitate their effectiveness for these two native ungulates.

Based on camera trap data collected by CDFW, the presence of the following animals has also been confirmed at, or near, the crossing site: grey wolf (*Canis lupus*), cougar (*Puma concolor*), black bear (*Ursus americanus*), and smaller mammals such as rabbits, gophers, voles, mice, and squirrels. The design elements described below, include the landscaping, overpass structure, and fencing, addressed the needs of these species as well.

5.1. Bridge Geometry

This wildlife overpass along US-97 was designed to span three lanes of traffic, each lane is 3.7 m (12 ft) wide. It also needs to cross over two shoulders on either side of the three lanes, each shoulder consists of 9.1 m (3 ft) of asphalt and 2.4 m (8 ft) of unpaved landscape. This results in a road width of 17.7 m (58 ft) under the overpass shown in Figure 9. The edge of the asphalt transitions to an upward sloped section to the abutments allowing Caltrans space to conduct below deck maintenance inspections (Figure 9).

The design clearance height for the bridge is 5.3 m (17.5 ft), which provides an additional 300 mm (1 ft) of structure clearance for highway bridges designed in the U.S. Caltrans engineers opted for the additional clearance height to reduce the likelihood of a vehicle impact on the FRP structure, given its specialty repair procedures that would be required in the event of an overhead strike. Using the typical Caltrans standards for horizontal clearance and slope to the abutments, a bridge span of 35 m (115 ft) was selected with guidance from Caltrans structural engineers. An elevation view of the bridge span and clearance envelope can be seen in Figure 9.

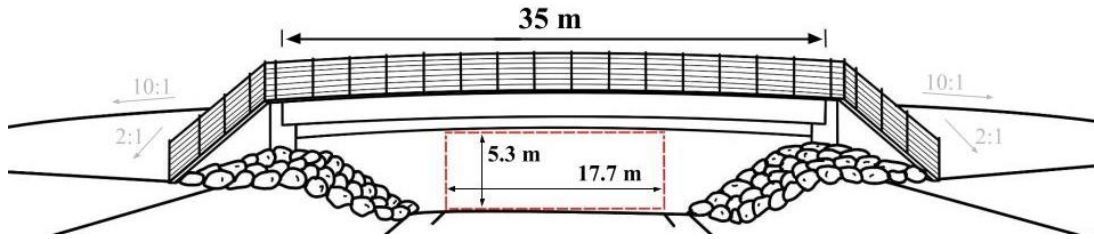

Figure 9: Elevation view of the US-97 wildlife overpass.

The below-grade road characteristic at Grass Lake Summit makes the adjacent soil grades on each side of the highway suitable for minimizing the fill required for the approaching slope to the structure. A slope that is less than 20% (5:1) is sufficient for elk crossing, but a flatter approach closer to 10% (10:1) is recommended to provide ample visibility across the structure for elk and deer. In addition to the approach slope's grade, an ideal crossing structure for large wildlife, such as elk, would have a recommended width of 50 m (164 ft).

A plan view of the wildlife overpass can be seen in Figure 10, with an aerial representation of the bridge footprint in Figure 11, showing the estimated placement and footprint at Grass Lake Summit.

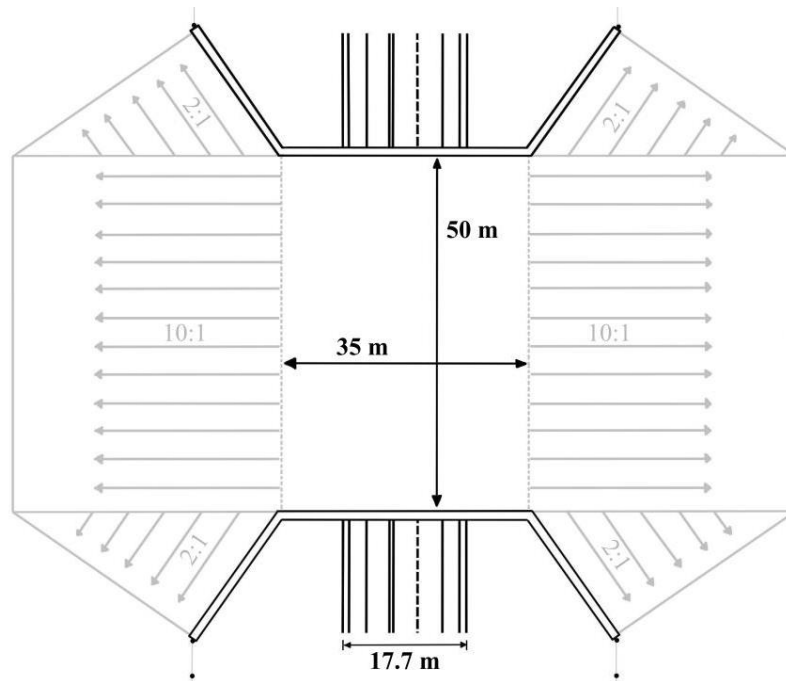

Figure 10: Plan view with dimensions of the US-97 wildlife overpass.



Figure 11: Aerial representation of the US-97 FRP wildlife overpass footprint.

Note: The map base layer was taken from Google Earth. Although the surrounding area looks like short brush, they are pine trees and do not represent the true height relative to the crossing structure.

5.2. Landscaping Design

The type of landscape required on top of the overpass is dependent on the target species and is intended to support their use of the structure by providing familiar vegetation. For the target species, elk, open grassy habitat is sufficient. Other, smaller species, or less mobile species, may benefit from hiding and thermal cover provided by woody shrubs, piles of rocks, downed logs, and other types of materials that break up the openness of the crossing. Thus, heterogeneity of habitat structure, or plant community physiognomy, ensures that species that avoid, or are vulnerable in, openings are considered in the landscape design. Therefore, the overpass structure's landscaping should include a combination of open grassy spaces intermixed with various woody vegetation and physically complex areas, such as rock piles.

5.2.1. Surface Aggregates and Vegetation

The depth of the soil required on an overpass is dependent on the species and the physiognomy of the vegetation – its structure, appearance, canopy cover – selected for the landscaping. To support the plant species for the US-97 overpass structure, it is recommended that a minimum depth of 310 mm (1 ft) of organic soil be used for vegetation, comprised of forbs and sod forming grasses; 610 mm (2 ft) is recommended if low growing shrubs and deeply rooted bunch grasses are planted. Deeper soils are recommended for larger shrubs and trees, approximately 1 m (3.3 ft) or more, if feasible.

To accommodate elk and deer use of the structure, the landscape design should include a combination of native grasses, forbs and shrubs that provide a rich mix of species. The lack of knowledge related to the relationship of animals with artificial landscape materials (e.g., tire piles, FRP members, small water guzzlers) has created an emphasis on the use of natural materials. Thus, native materials that provide hiding cover for small animals (e.g., logs, rocks,

tree limbs, root wads) and native vegetation and plant species are recommended for this overpass.

Native seed mixes using local genotypes are recommended to establish vigorous native plants to help to reduce the encroachment of exotic, invasive species on or adjacent to the crossing structure. A short list of some desirable trees, shrubs, forbs and grasses naturally occurring in this area of the Cascade Mountains (Table 4) could be used on top of the overpass and to rehabilitate adjacent disturbed area from construction. The list is illustrative and not exhaustive. Special attention should be paid to select species that are adapted to the drier more xeric habitats of the area.

Further exploration of whether local ecotypes of these and other native species used for revegetation are commercially available would be necessary. To assure local ecotypes are used, seeds or vegetative cuttings could be harvested from native plants at, or near, the crossing site. The collected seeds and cuttings could then be used by a local landscape nursery to grow, multiply and harvest plants for restocking the disturbed areas of the crossing site.

Table 4: A short list of native species that could be used to reclaim US-97 wildlife overpass site that are present in adjacent habitats.

Scientific Name	Common Name
Trees	
<i>Pinus contorta</i>	Lodgepole pine
<i>Pinus ponderosa</i>	Ponderosa pine
Shrubs	
<i>Artemesia tridentata</i>	Big sagebrush
<i>Chrysothamnus viscidiflorus</i>	Green rabbitbrush
<i>Purshia tridentata</i>	Antelope bitterbrush
<i>Ribes cereum</i>	Wax currant
<i>Symphoricarpos albus</i>	Common snowberry
<i>Arctostaphylos patula</i>	Greenleaf manzanita
Forbs	
<i>Antennaria microphylla</i>	Littleleaf pussytoes
<i>Arnica cordifolia</i>	Heartleaf arnica
<i>Balsamorhiza sagittata</i>	Arrowleaf balsamroot
<i>Cornus canadensis</i>	Bunchberry dogwood
<i>Fragaria virginiana</i>	Strawberry
<i>Lupinus spp.</i>	Lupine species
Grasses	
<i>Festuca idahoensis</i>	Idaho fescue
<i>Poa sandbergii</i>	Sandberg bluegrass
<i>Pseudoroegneria spicata</i>	Bluebunch wheatgrass
<i>Sitanion hystrix</i>	Squirreltail
<i>Stipa occidentalis</i>	Western needlegrass

A design consideration for wildlife bridges is the longitudinal slope of the structure to prevent the ponding of water on the bridge. Efficient water movement will be accommodated through the design of an appropriate camber in the FRP super structure, creating a visible, shallow arched appearance from the roadway. A waterproof membrane should be placed over the entire concrete deck before applying the surface substrate. Perforated pipes, 100 mm (4 in.) in diameter, placed in the longitudinal direction of the crossing structure should be placed at the bottom of the gravel substrate and eventually be exposed at the ends of the bridge. At both ends of the structure, the exposed portion of the drainage pipes should then be covered with a 200 mm (8 in.) layer of granular material (30-60 mm [1-2 in.] diameter) to collect the excess water. A landscape fabric will be placed over the gravel to prevent settling of the organic soil layer into the granular base, but still allow water to penetrate through the fabric. Approximately 760 mm (30 in) of topsoil should then be applied to accommodate the native plant species identified in Table 4. The slight grade provided by the superstructure camber will allow for the natural flow of surface water from the center of the overpass to the ends of the bridge and ultimately into the approach grade's subsurface.

5.2.2. Habitat Planting Strategy for Crossing Structure

A relatively low-density dry coniferous forest surrounds the crossing site on both sides of the highway. The forest canopy is dominated by ponderosa pine (*Pinus ponderosa*). The open grown single layer coniferous forest has a few scattered understory trees combined with a relatively sparse mix of woody shrubs, herbs and grasses (see Figure 8). The vegetation grows on a substrate of volcanic deposits – ash, pumice, tephra – that have sporadically occurred in the region for millennia, as well as rhyolitic and andesitic flows (Simpson 2007). The local landscape also contains a mix of rocks and boulders that naturally occur throughout the area.

For the crossing structure, the creation of habitat with zones that accommodate the movement preferences of a range of smaller mammal species as well as elk and deer through a semi-vegetated landscape was the recommended strategy of the ARC Solutions CoLab and is shown in Figure 12. Combined, there are three different parallel bands that provide a variety of habitats and hiding cover needs for the diverse wildlife species that potentially will use the structure. It is recommended to use locally sourced logs and volcanic rocks. These rocks are lighter than other types of rocks derived from granite or other metamorphic sources and reduce loading of the structure. The dark volcanic rocks also blend nicely with the surrounding landscape and black recycled-plastic FRP used for the sound/light barriers and fencing. The plants selected should be those that are best suited for a xeriscape to reduce the need to retain water on the structure.



Figure 12: Planting strategy with clear path of visibility through the center of the structure.

At each end of the overpass, along the barrier walls, a gravel path should be created where no vegetation is planted. This will allow maintenance personnel to easily access the sound and light barrier along the side of the structure for inspection, maintenance, or repairs. Along the north side of the crossing would be continuous shrub/grass/herb cover for smaller, low mobility species. This band of cover is 9.1 - 12.2 m (30-40 ft) wide and provides continuous cover so smaller animals are not exposed to any large openings as they cross the structure. The center habitat band of the

crossing is a 24.4 - 30.5 m (80-100 ft) wide area seeded with low growing grasses. This area will provide clear visibility across the entire structure for elk and deer. There are minimal obstacles to interfere with animal passage. On the south side of the are clusters of hiding cover provided by logs, volcanic rocks, and scattered shrubs. This allows species the ability to jump between the covered areas as they cross, to rest or feel secure (e.g., from birds of prey). Combined, the crossing's vegetative design offers species with varying needs, a mix of habitat in three different avenues or zones of passage: 1) a continuous woody shrub dominated area, 2) an open grassy central area designed for the two focal species, deer, and elk, as well as other large mammals; and 3) a band of varying habitat islands – low growing vegetation, shrubs, logs and rock piles. A representation of this landscaping strategy can be seen in Figure 12.

For the approaching slopes to the crossing structure, deeper soils of 1 m (3.3 ft) or more could be used to replace ponderosa pine trees in the disturbed footprint from construction. This would keep the gap in the forest overstory canopy to a minimum. Based on the field review of the site, breaks in the ponderosa pine forest's canopy equal to the 35 m (115 ft) span of the overpass commonly occur throughout the surrounding area.

5.2.2.1. Summary of Landscape Recommendations

Below is a brief overview of the recommended landscaping aspects of the wildlife crossing:

- Maximum of 20 cm (8 in.) granular drainage material, plus 76 cm (30 in.) of organic soil, for a total of 97 cm (38 in.) material on top of the structure.
- Camber in the structural girders to facilitate water drainage off the crossing structure to the surrounding subsurface soils.
- The landscaping for the crossing structure will include a large central open area covered with native grasses to facilitate elk movement.
- Continuous areas and islands of hiding cover will be provided via woody shrubs, rock piles, root wads and other native materials for smaller animals.
- Local ecotypes of native plants – trees, shrubs, forbs, grasses – should be used for vegetating the site.
- Locally sourced volcanic rocks and woody debris will be used for small mammal habitat.

5.3. Overpass Structure

With knowledge of the target species crossing behavior and the extent of soil, drainage, and landscaping features described in section 5.2, a preliminary design of the FRP elements of the wildlife overpass was completed. The design utilizes recommended crossing geometry and loading to create a feasible FRP tub girder cross section with a composite concrete deck that meets the objectives of the US-97 site.

5.3.1. Overpass Loading

Working with Caltrans structural engineers, service loads and load combinations were developed for the preliminary design of the crossing superstructure. Loads considered were self-weight, superimposed dead loads, and vehicle, animal, and snow live loads. Recommended loads are provided in Table 5 and briefly summarized below.

Table 5: Design Load Summary

Element	Unit Weight (kg/m ³)	Dimension	Loads			Reference
			Concentrated (kg)	Line (kg/m)	Uniform (kg/m ²)	
Pervious drainage fill	1,602	20 cm	-	-	327	-
Earth fill (lightly compacted)	1,602	76 cm	-	-	1,465	-
Vegetation	-	-	-	-	24	-
FRP tub girder	-	2.3 m spacing	-	164	78	-
Precast concrete form	2,403	8 cm	-	-	186	-
Cast in place concrete	2,403	10 cm	-	-	244	-
Concrete soil curb	2,403	1.1 m tall	-	164	156	-
FRP sound and light barrier	961	2.4 m	-	104	98	-
H-10 Truck loading	-	-	9,072	-	171	AASHTO, 2014
Elk	-	10 cm x 10 cm	454	-	171	-
Livestock	-	-	-	-	488	Pederson et al., 1983
Equestrian	-	10 cm x 10 cm	454	-	171	AASHTO, 2009
Pedestrian load	-	-	-	-	439	AASHTO, 2009
Snow (strength limit state)	-	-	-	-	610	Caltrans
Snow (extreme event)	-	-	-	-	781	Caltrans

The self-weight of the structure includes a uniformly distributed load of 78.1 kg/m² (16 psf) for the FRP tub girder, an 80 mm (3 in.) precast concrete form of 186 kg/m² (38 psf), and a 100 mm (4 in.) cast-in-place concrete deck weighing 244 kg/m² (50 psf). Precast and cast-in-place concrete will use FRP rebar instead of carbon-steel to eliminate the corrosion potential and increase the service life of the overpass.

Superimposed soil dead loads assumed a partially compacted unit weight of 1600 kg/m³ (100 pcf) for the granular drainage and organic soil loading. This value represents an average of the unit weight of traditional compacted soil 1920 kg/m³ (120 pcf) and engineered growth media from commercial sources 1120 kg/m³ (70 pcf). For a total soil thickness of 965 mm (38 in), the distributed load is 1860 kg/m² (380 psf). An additional superimposed dead load of 24 kg/m² (5 psf) was included to account for larger, individual plants or cover objects that may be dispersed along the crossing structure's length. For the two girders on the outside of the crossing, additional dead loads for a 1.1 m (44 in.) tall concrete curb weighing 165 kg/m (110 lb/ft) and a 2.4 m (8 ft) tall recycled plastic FRP sound/noise barrier at 104 kg/m (70 lb/ft) were included. Distributing these loads to a single girder on the outside of the crossing results in loads of 156 kg/m² (32 psf) and 98 kg/m² (20 psf) for the curb and barrier, respectively.

The overpass structure was considered a pedestrian bridge for vehicle and animal live loads. A single lane of an H10 design vehicle (two-axle truck weighing 9,100 kg [20,000 lbs]) or approximately 171 kg/m² (35 psf) was used without a lane load; this assumed that multiple vehicles would not be on the bridge at one time. It was also assumed that construction equipment used to

place and distribute the soil and vegetation on the bridge will not exceed a single lane of a H-10 design truck. Elk loading on the bridge was treated as an equestrian concentrated hoof load of 450 kg (1,000 lbs) for the concrete deck design. The distributed load for a herd of elk crossing two-wide over a 2.3 m (7.5 ft) tributary tub girder spacing was assumed to be 170 kg/m² (35 psf).

The US-97 crossing location is in a site-specific area that has already determined snow loads, mostly for non-transportation structures. Based on the assumption that snow removal will not occur on the wildlife overpass, a 50-year accumulation event (ASCE/SEI, 2017) was used to determine a snow load of 610 kg/m² (125 psf). This load is specified by the Siskiyou County building department for the design of building roofs and other structures. An extreme snow event loading of 780 kg/m² (160 psf) was also considered for the overpass structure because an accumulated snow load of nearly 4.9 m (16 ft) occurred in 1959 within 32 km (20 miles) of the crossing location.

A deflection limit of $L/600$ (L = bridge length in inches) was used to select the size of the girders. This is the same deflection limit used for highway bridges and accounts for vibration and driver perception from heavy and dynamic truck loading. A larger bridge deflection limit may be reasonable for wildlife crossings, however the more stringent limit for highway structures was used due to the lack of understanding of wildlife's perception and tolerance of vibration.

5.3.2. FRP Superstructure

The FRP system selected for the crossing superstructure is a composite tub (CT) girder manufactured and designed by Advanced Infrastructure Technologies (AIT). The CT girder system consists of lightweight FRP tub girders that are supported on standard foundations with precast panels or cast-in-place concrete bridge deck. A previously constructed bridge using AIT's CT girders can be seen in Figure 13 (a) and 13 (b). The first CT girder bridge was constructed in 2020 in Maine. AIT is currently working on additional bridge designs for Maine, New Hampshire, and Florida DOTs, with spans ranging up to 32 m (105 ft) in length.

The estimated cross section dimensions of the CT girder for the US-97 wildlife overpass are shown in Figure 14. For an overall crossing width of 50 m (164 ft) and a girder spacing of 2.3 m (7.5 ft), 22 girders with an approximate depth of a 142 cm (4.7 ft) will be used. These dimensions were estimated by AIT, with their proprietary software, to calculate dimensions of the girder and the number of fiber-matrix layers required for each structural plane. An estimated design load of 2,441 kg/m² (500 psf) was given to AIT based on discussions between Caltrans and the WTI Team. The dimensions described in Figure 14 are approximate estimates to the size of the CT girder required for the US-97 wildlife overpass.



Figure 13: The CT girder bridge system. (a) Left, a cross section of the CT girder showing the foam cores and (b) right, installed CT girders during first construction in Hampden, Maine, 2020.

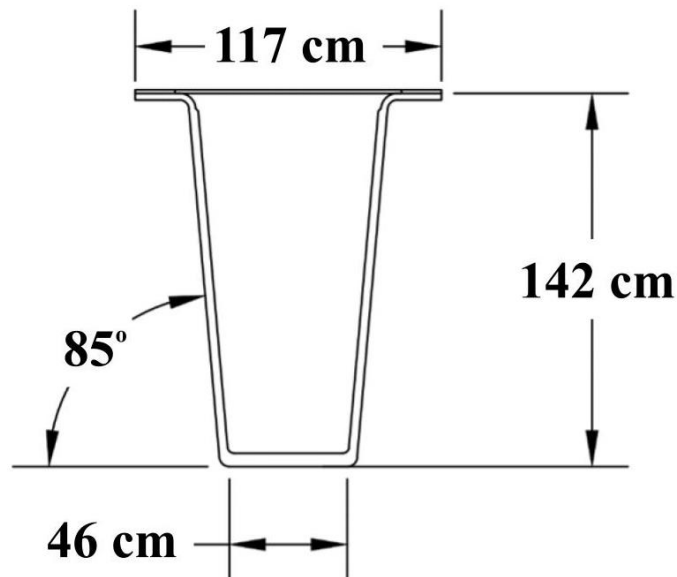

Figure 14: Cross section of the preliminary design for the CT girder from AIT Bridges.

The method of constructing the CT girder bridge is described below, using Figure 15 as a reference to the associated wildlife bridge elements. To assist with accelerated construction, a 75 mm (3 in.) precast concrete panel, B in Figure 15, is attached to two tub girders, A in Figure 15. FRP rebar will eliminate corrosion in the reinforcement of the decking and is predicted to help minimize maintenance. The J-shaped FRP through-bolts on the sides of the CT girder flanges provide the connection required for composite action between the girder and concrete panel, C in Figure 15. This two - CT girder assembly unit is placed on top of the abutments and reduces the number of lifts, contributing to a more efficient construction process than a similar sequence for heavier steel and concrete girder bridge construction. In addition to faster girder installation, the

precast concrete panel on top of the 2-CT girder assembly unit eliminates formwork required for a full-depth cast-in-place concrete deck.

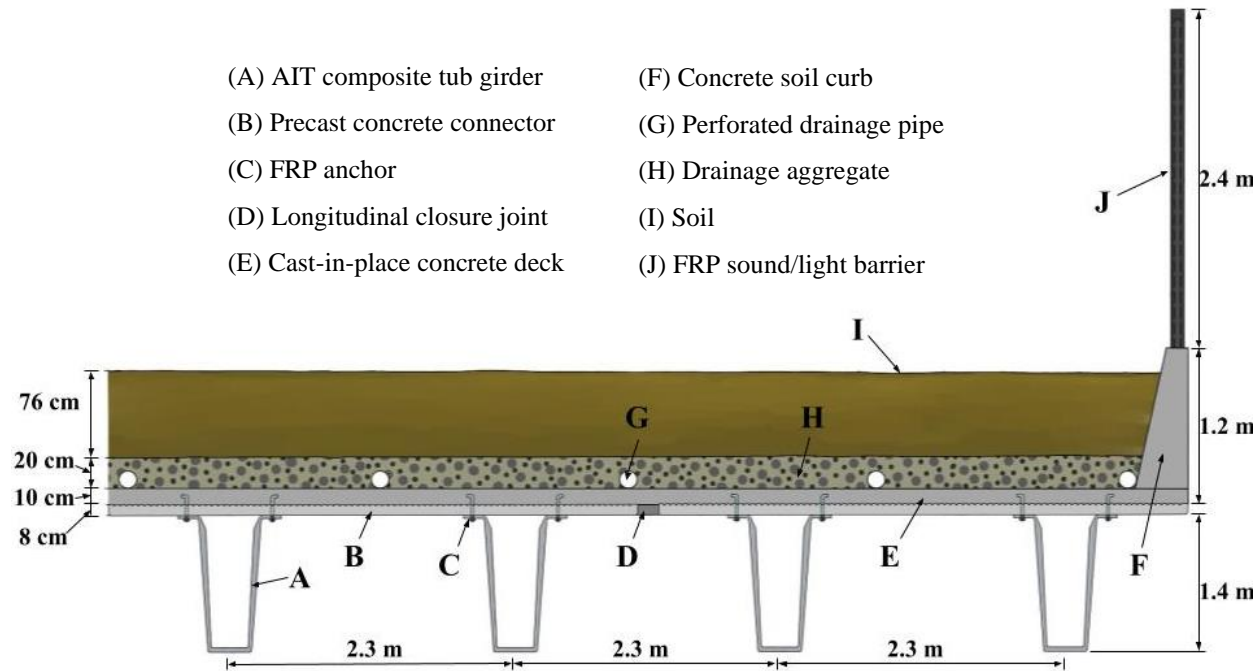

Figure 15: Cross section of the wildlife overpass showing the layout of the girders, concrete deck, soil, drainage, and barriers on the bridge span.

Note: Image not drawn to scale.

After all the 2 – CT girder assembly units are in place, the precast concrete panels are connected by longitudinal concrete closure joints, D in Figure 15. The precast concrete surface provides the formwork for the additional 4 in. cast-in-place reinforced concrete deck, E in Figure 15. The cast-in-place deck also uses FRP rebar. The connection between the precast and cast-in-place concrete is provided by the same FRP J-shaped anchors that pass through the precast member, C in Figure 15. An intentionally roughened surface on the top of the precast panels provides the additional shear connection for composite action between the cast-in-place concrete and precast concrete. The FRP J-bolts contribute to a corrosion-free structural assembly. Along each side of the bridge, a concrete curb, F in Figure 15, with FRP rebar is constructed on top of the completed deck to retain the soil on the structure and support the recycled plastic FRP sound and light barrier, J in Figure 15.

5.3.3. Sound and light barriers

There are many alternatives for providing an FRP sound and light retaining barrier along the edges of a wildlife overpass. Variations include cantilevered hollow tube posts to attach barrier elements or prefabricated FRP panels that can be installed quickly and directly to the concrete curb. Many of the available products are not labeled or marketed specifically as a sound-reducing member. Therefore, additional investigation into their effectiveness at reducing the decibels at various wavelengths needs to be pursued.

The WTI Team recommends a simple recycled plastic FRP light and noise barrier design that resembles a traditional wooden fence as shown in an artistic rendering (Figure 16). After examining recycled plastic board densities from multiple manufacturers, it was noted that the FRP boards range from 720-960 kg/m³ (45-60 pcf). The FRP boards using recycled plastic are denser than traditional wood fencing and are predicted to significantly reduce the sound from passing vehicles below when compared to a wood fence. This will also eliminate light and reflected light from vehicle headlights and running lights from the line-of-sight of animals while they are on the overpass. The barrier design shown in Figure 16 uses recycled plastic FRP posts that have an I-beam cross-section; they are connected to the top of the soil-retaining concrete curb along the edge of the overpass. The I-shape enables FRP boards to slide quickly into the horizontal position, held in place by the I-shaped flanges.

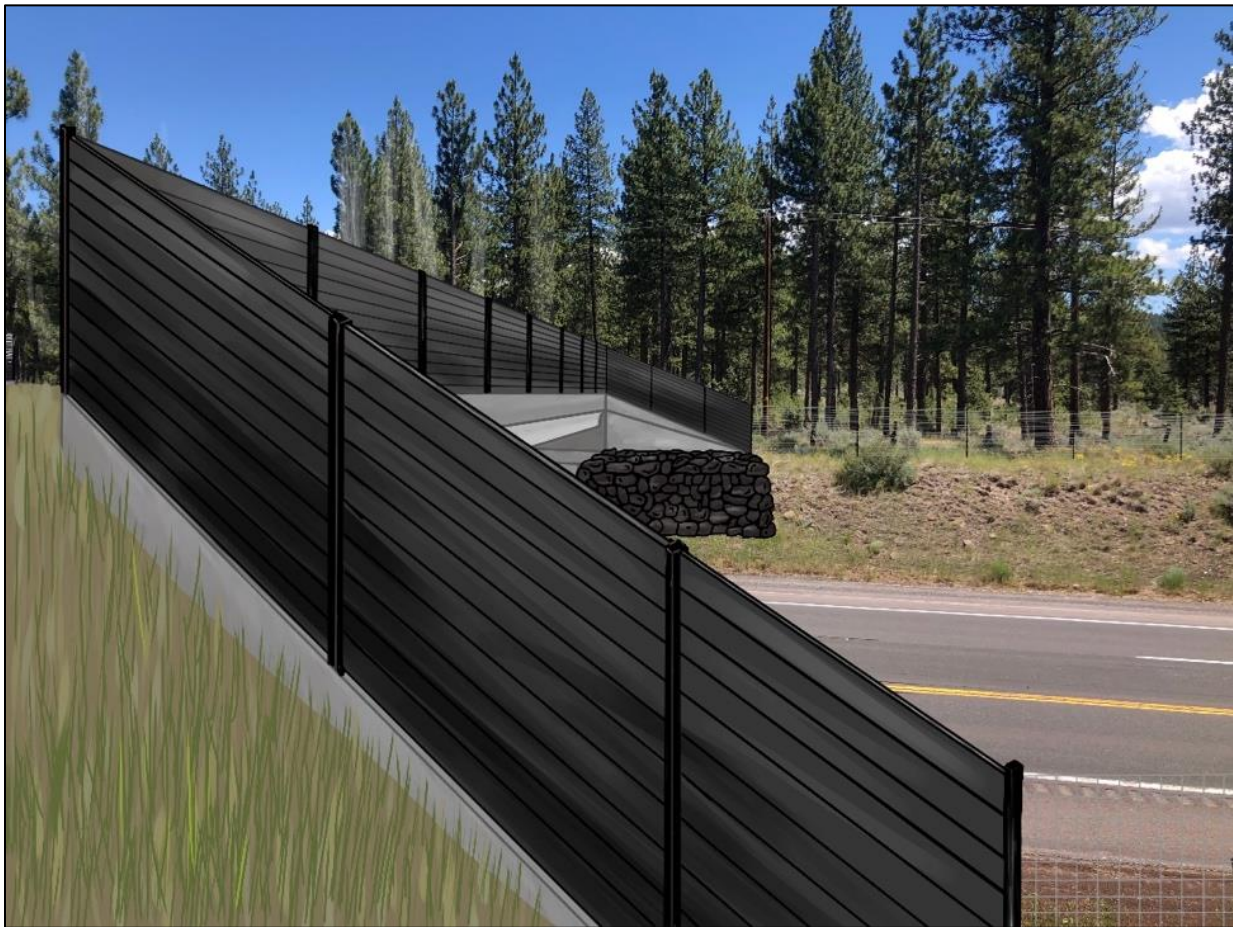

Figure 16: Recycled-plastic sound and light barrier installed on top of soil-retaining concrete curb.

5.4. Wildlife Fencing and Supporting Elements

Wildlife overpasses and underpasses with fencing, are proven measures that can significantly reduce WVCs with large animals, while at the same time provide safe crossing opportunities for many species of varying size. An overpass, without fencing, is often less effective or ineffective at reducing WVCs (Huijser et al. 2016). It is recommended that a minimum of 5 km (3 mi) of fencing be erected to reduce collisions with large wildlife at the US-97 wildlife crossing site. The fence ends that are furthest from the crossing structure should be designed to direct animals away from the road or be tied into existing fencing or landscape features to reduce the ability of wildlife to cross the road.

For the US-97 site, it is recommended to use recycled plastic FRP posts and boards for the wildlife fencing elements (e.g., fence posts, gates, jump-outs). Wildlife fencing made with FRP materials uses the same construction techniques as conventional steel and wood wire-mesh fences. Fence posts can either be driven into the ground for straight sections of fencing or placed in a concrete base with bracing for additional support at corners, slope changes and turns. Recycled-plastic boards are recommended for fencing elements because they will last longer than traditional materials, remove landfill waste, and can be recycled if sections of the fence need to be replaced. A rendering of the recycled plastic fencing elements can be seen in Figure 17.



Figure 17: Representation of recycled-plastic posts for use in wildlife fencing, gates, and jump-outs.

Road access points through the wildlife fencing along the US-97 mitigation area should be minimized to reduce potential points for animals to breach the fencing and enter the roadway. Each access location should be addressed individually with the appropriate mitigation method (e.g., cattle guard, gate, electric mat) and will be influenced by land ownership and public use requirements.

Wildlife jump-outs, such as the example shown on the right side of the fencing in Figure 17, should be placed along the fence every 0.5-0.8 km (0.3-0.5 mi), with additional jump-outs added near road access points and areas where animals are more likely to be on the highway side of the fencing.

6. CONCLUSION



Figure 18: Rendering of US-97 FRP wildlife overpass with Mt. Shasta in the background.

The preliminary design of an FRP wildlife overpass for a specific crossing location has allowed the WTI Team to document an example of a feasible, efficient, and constructible alternative to that using conventional steel and concrete materials. The benefits of FRP materials have been maximized, through their use in the US-97 superstructure, concrete reinforcement, fencing, and light and sound barriers. Task Report 9 documents a FRP wildlife overpass, such as the one shown in Figure 18, that can be implemented by a state DOT with minimal departure from traditional materials and construction techniques.

7. REFERENCES

- American Association of State Highway Transportation Officials (AASHTO). 2009. LRFD Guide Specifications for the Design of Pedestrian Bridges. AASHTO, Washington, DC.
- American Association of State Highway and Transportation Officials (AASHTO). 2014. LRFD Bridge Design Specifications. AASHTO, Washington, DC.
- American Society of Civil Engineers (ASCE)/SEI. 2017. Minimum Design Loads and Associated Criteria for Buildings and Other Structures. ASCE, Reston, VA.
- Bell M, Ament R, Fick D. 2020a. TPF-5 (358), Improving connectivity: innovative fiber-reinforced polymer structures for wildlife, bicyclists and/or pedestrians. Report P701-18-803 TO 2. Nevada Department of Transportation, Carson City, Nevada.
- Bell M, Fick D, Ament R, Lister N-M. 2020b. The use of fiber-reinforced polymers in wildlife crossing infrastructure, Sustainability, MDPI, Open Access Journal, vol. 12(4), 1-15, February 2020.
- Ford AT, Barrueto M, Clevenger AP. 2017. Road mitigation is a demographic filter for grizzly bears. Wildlife Society Bulletin, 41(4):712-719.
- Huijser MP, McGowen P, Fuller J, Hardy A, Kociolek A, Clevenger AP, Smith D, Ament R. 2007. National wildlife-vehicle collision reduction study. Report to Congress. U.S. Department of Transportation, Federal Highway Administration, Washington DC, USA.
- Huijser MP, Duffield JW, Clevenger AP, Ament RJ and McGowen PT. 2009. Cost-benefit analyses of mitigation measures aimed at reducing collisions with large ungulates in North America; a decision support tool. Ecology and Society 14 (2):15. Online at: <http://www.ecologyandsociety.org/vol14/iss2/art15/>
- Huisjer MP, Fairbank ER, Camel-Means W, Graham J, Watson V, Basting P, Becker D. 2016. Effectiveness of short sections of wildlife fencing and crossing structures along highways in reducing wildlife-vehicle collisions and providing safe crossing opportunities for large mammals. Biological Conservation, 197, 61-68.
- Huijser MP, Begley JS. 2019. Large mammal-vehicle collision hot spot analyses, California, USA. Report No. 4W6693, California Department of Transportation, Sacramento, CA.
- Huijser MP, Ament RJ, Bell M, Clevenger AP, Fairbank ER, Gunson KE, McGuire T. 2021. TPF-5(358), Animal Vehicle Collision Reduction and Habitat Connectivity – Literature Review. Report No. 701-18-803 TO 1. Nevada Department of Transportation, Carson City, NV.

Lister N.-M., Brocki M, Ament R. 2015. Integrated adaptive design for wildlife movement under climate change. *Frontiers in Ecology and the Environment*, 13(9):493-502.

Pedersen J, Bell G, Riskowki G. 1983. Midwest plan service structure and environment handbook. Iowa State University, Ames, IA.

Rytwinski T, et al., 2016. How effective is road mitigation at reducing road-kill? A meta-analysis. *PLoS one*, 11(11): p. e0166941.

Sawyer H, Rodgers PA, Hart T. 2016. Pronghorn and mule deer use of underpasses and overpasses along US Highway 191. *Wildlife Society Bulletin*, 40(2):211-216.

Simpson, M. 2007. Forested plant associations of the Oregon East Cascades. US Department of Agriculture, Forest Service, Pacific Northwest Region. Seattle, WA.

Sullivan JM. 2011. Trends and characteristics of animal-vehicle collisions in the United States. *Journal of Safety Research*, 42(1):9-16.

8. APPENDIX A: PROPOSED DESIGN LOCATIONS

8.1. Submitted Design Sites

This appendix sections includes a summary of the five proposed design locations for an FRP wildlife overpass that where not selected for this project. Each location has been summarized based on the proposals submitted to the WTI Team. It includes all the important information that was provided about each site and is what was sent to the TAC members for their feedback on which location is most suited for this design project.

8.1.1. USA Parkway/State Road 439 in Storey County, Nevada

This proposed site is located just south of the city of Clark, Nevada, which is about 15 miles east of Reno (Figure 19). It is a four-lane highway with a center left-turning lane, i.e. five lanes in total. This area gets lots of exposure due to its location and the amount of traffic using the state highway.



Figure 19: Proposed design site location for SR-439 in Storey County, Nevada.

The proposed site for a wildlife overpass is located on a blind s-curve. This location has been identified as one of the top safety hotspots in Nevada related to AVCs and is the area with the most frequent feral horse-vehicle collisions per year. This location has support for a wildlife overpass to address safety concerns by horse advocate groups. The main blockchain property owners are

supportive of horses and is currently organizing a working group to manage horse movements in the area and have support from most of the businesses in the area.

WTI Notes on SR-439

The four-lane road with center median presents a larger challenge given the span the bridge will require. There is currently no FRP bridge designed and tested that is capable of such a large span. Although we are confident this material can achieve such a distance, it is beyond the scope of this project and result in additional challenges in design and implementation. Therefore, the FRP bridge will have to be designed to land in the center median. Fencing for horses is different than wildlife and will need to be upgraded to not allow wildlife to penetrate it. A concern is that there is lots of businesses in the area and therefore lots of access points that will have to be dealt with regarding fencing. The fence will either have to have a lot of breaks in the fence or be fenced around the perimeter of the whole business complex.

8.1.2. State Road 139 in Modoc County, California

This proposed site is located between post miles 30 and 40 on SR-139 in northern California (Figure 20). It is a two-lane road with 12 ft lanes and 4 ft shoulders on each side. The surrounding adjacent land is generally flat with little change in elevation.

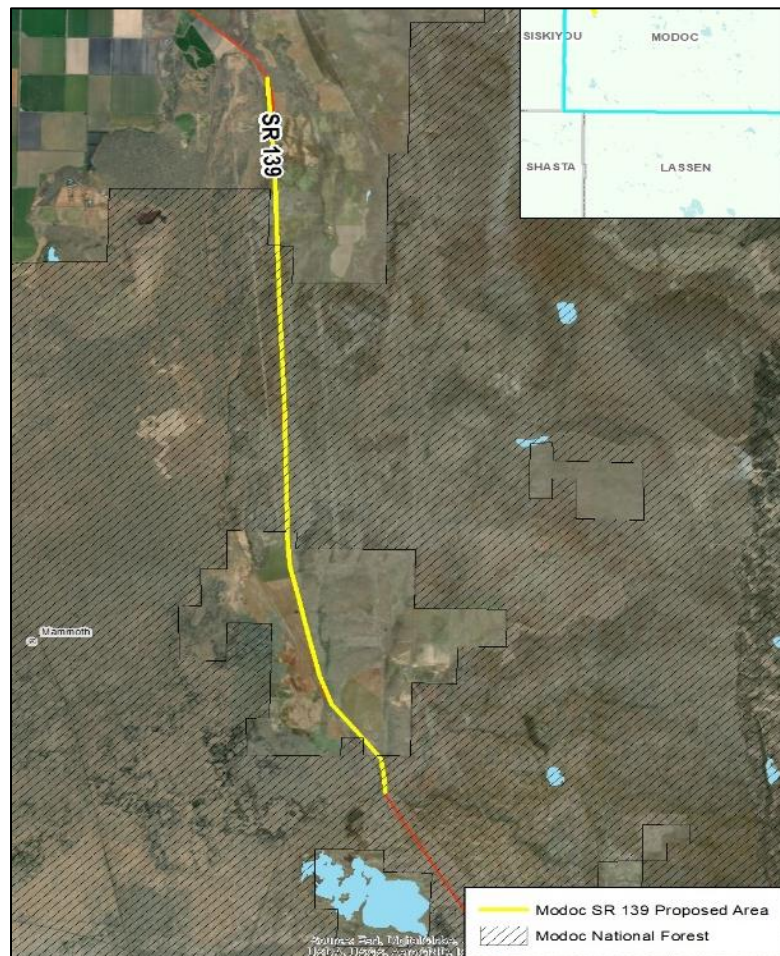

Figure 20: Proposed site location for SR-139 in Modoc County, California.

The target species for the wildlife overpass is mule deer. This section of road passes through the Interstate Herd winter migration route (Figure 21). Deer commonly congregate near, and on, the road during winters with above average snowfall. There have been over 100 dead deer counted along the road during winter migration.



Figure 21: Mule deer crossing SR-139 during the winter months.

This area has the support of local and state agencies. The CDFW, California Highway Patrol (CHP), California Deer Association (CDA), and the Modoc public have identified this as a problem area and are concerned about safety. Caltrans plans to mitigate this the area with a crossing structure and wildlife fencing in the future.

WTI Notes on SR-139

This is a low volume road but has extra-large, slow-moving, agricultural vehicles. This can create problems when addressing the clearance envelope required for the overpass, as the normal clearance allowance will most likely be insufficient to allow agricultural equipment to pass under it. It will have to be discussed further to figure out height requirements for the bridge and other challenges that may arise due to the size of agricultural equipment.

8.1.3. State Road 20 in Colusa County, California

This proposed site is located along SR-20 between post miles 9.8 and 12.4. It has been identified to have both safety and genetic barrier concerns by Caltrans and the CDFW. This location is due to receive a road realignment of the curves, wider shoulders, and rumble strips along certain areas of the road. Caltrans wants WVC mitigating infrastructure added to the construction plan. This would be ideal because there is not expected to be a large amount of future AADT growth and is not expected to receive any additional future lane expansions. The current peak traffic volume is

about 870 vehicles/hour. This location has good exposure as this route is a major connector between California's central valley and the wine country to coastal destinations within Mendocino, Sonoma Lake, and Humboldt County. There is a wide range of topography changes along this section of road that range from steep slopes and valleys to gentle grasslands and meadows. The CDFW has already obtained numerous conservation easements within the project area and are in the process of obtaining more.

The focal species for this area is elk. This has been prioritized by CDFW as an area of great concern for migratory and resident elk populations. Collaring data shows that SR-20 has become a barrier for the resident elk herd (Figure 22). Other wildlife in the area that will benefit from a wildlife overpass are deer, bear, cougar, coyote (*Canis latrans*), and other small animals.

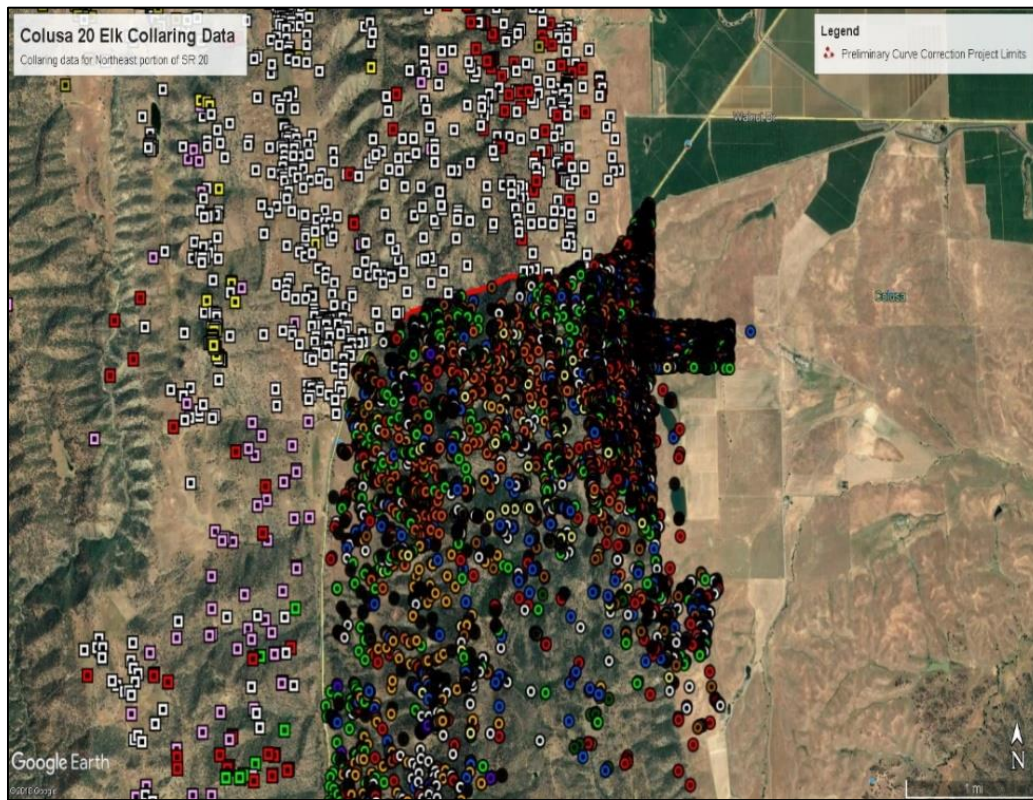

Figure 22: GPS data of collared elk along the proposed SR-20 mitigation site.

There is great existing inter-agency partnerships and relationships in both the environmental and engineering divisions that are in support of WVC mitigating infrastructure.

WTI Notes on SR-20

This site has various topography elements and gives options to placement and structure type. The barrier and safety concerns caused by the two-lane road make it an ideal site for a wildlife overpass and fencing.

8.1.4. U.S. Highway 101 in Humboldt County, California

This proposed site is located on a two-lane section of road along US-101 between post miles 113 and 116 (Figure 23). The current estimated AADT is 4,000 vehicles. The mitigation area is located within Humboldt Lagoons State Park (HLSP) and extends three miles south of the “Southern Gateway” to Redwood National and State Park (RNSP) system.

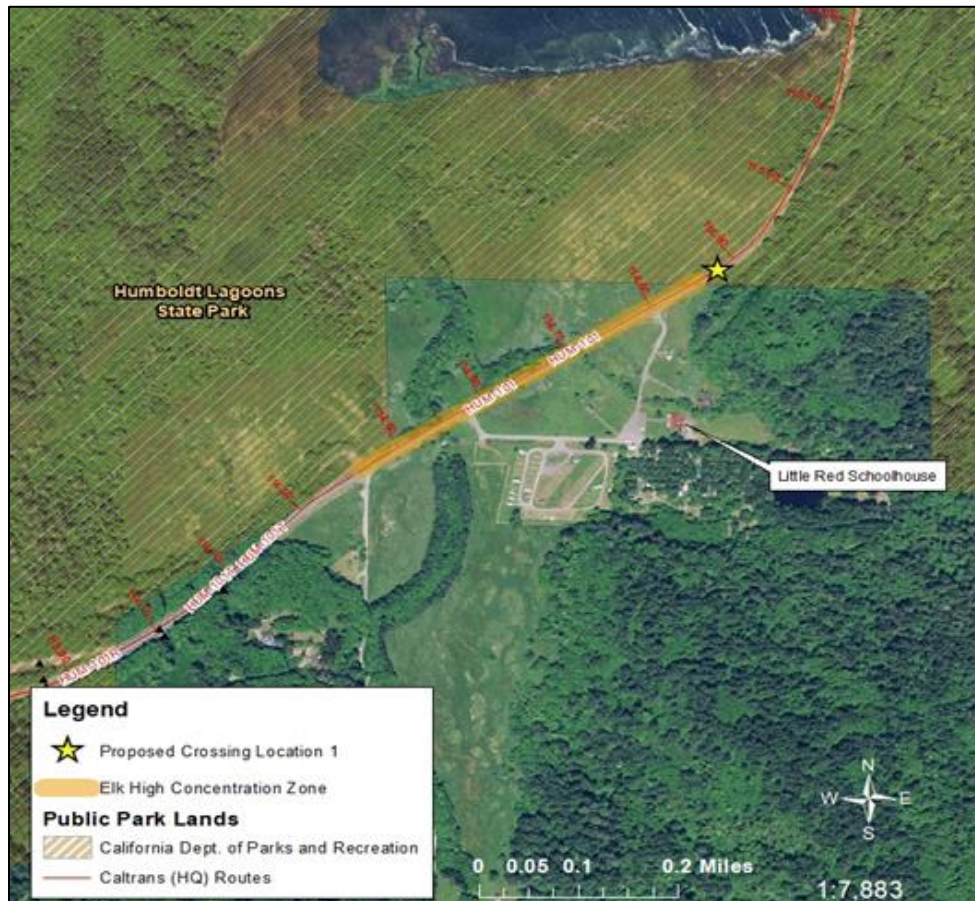

Figure 23: Proposed mitigation location along US-101 in Humboldt County, California.

This location has been identified as a high priority area for addressing wildlife connectivity. There are approximately 45,000 visitors to HLSP and up to 500,000 visitors to RNSP each year, with most of them traveling through the proposed site location. The surrounding area is generally flat and consists of slopes between 0-2%. Although the water table is only 30-39 inches below the surface, there is no ponding in the area and flooding is rare. There are no wetlands or bodies of water within 600 ft of the proposed location.

The target species for this area are Roosevelt elk, black-tailed deer, and black bear. They are also the most common mortalities along this section of road. GPS collared elk in the area were estimated to make 280-284 road crossings a year from 2017 to 2019. That is more than any other location monitored. This section of US-101 has one of the highest rates of deer-vehicle collisions across the entire state of California and is estimated to cost drivers an estimated \$22,000 per mile per year. Other species an overpass

will benefit are the endangered Humboldt marten (*Martes caurina humboldtensis*), the federally proposed threatened west coast fisher (*Pekania pennanti*), bobcat (*Lynx rufus*), beaver (*Castor canadensis*), river otter (*Lontra canadensis*), and coyote.

There is stated support by Caltrans District 1 management, environmental planning, design, and traffic safety departments for this mitigation site. There is also a local scientific community, including biologists and researchers from USFWS, CDFW, California State and National Parks, and Humboldt State University that are in favor of wildlife mitigation efforts to increase safety along this section of road.

WTI Notes on US-101

Looking to connect threatened and endangered fishers and marten will involve landscaping that may require larger loads which can include trees and other large debris. Research on the crossings of these animals will help understand the structural loads required by the bridge superstructure. The site's close proximity to a campground and schoolhouse have add concerns about people climbing the fence and using the bridge, which will reduce the effectiveness of the mitigation measures due to human presence.

8.1.5. State Road 126 in Ventura County, California

This proposed site is located along a four-lane road with a center left-turning lane that follows the Santa Clara River. The study area is along SR-126 between post mile VEN-21 and LA-5. This section of road separates the Santa Susana Mountains from the Los Padres National Forest. The Fish Hatchery road location is the optimal site location for an overpass based on the land use restrictions within the area (Figure 24). There is protected quality habitat on both sides of the road with no steep cliffs and provides natural drainage. SR-126 is an important connector between US-101 in Ventura and I-5 in Santa Clarita. It is estimated to have an AADT of 26,000 vehicles and will have high exposure to the public.



Figure 24: Proposed mitigation location along SR-126 in Ventura County, California.

The focal species for this location are mule deer, cougar, and mule deer. Other animals that will benefit from wildlife mitigation infrastructure include coyotes, bobcats, and gray foxes. Caltrans is in support of this project.

WTI Notes on SR-126

The 4-lane road with center median presents a larger challenge given the span the bridge will require. There is currently no FRP bridge that is designed and tested that is capable of spanning such large distances. Although we are confident this material can achieve such a distance, it is beyond the scope of this project and result in additional challenges in design and implementation. Therefore, the FRP bridge will be designed to land in the center median. Due to high urbanization in the area, additional considerations to wildlife fencing is needed to funnel animals safely over the road and to protected areas.

8.2. Additional Photos for the US-97 Site Visit

8.2.1. Site 1: Grass Lake



Figure 25: Grass Lake A potential site looking west.



Figure 26: The area north of Grass Lake A potential site that will require backfill to create the approach ramps for the wildlife overpass.



Figure 27: Standing south of US-97 on Grass Lake B looking west towards Grass Lake A.



Figure 28: Standing south of US-97 on Grass Lake B looking east-northeast towards the blind curve.



Figure 29: Grass Lake B looking south towards US-97 showing the little fill required for the approach ramps.



Figure 30: The railroad tracks south of US-97 at Grass Lake B proposed site.

8.2.2. Site 2: Horsethief Creek



Figure 31: Standing south of US-97 on top of the embankment at the proposed Horsethief Creek site, looking east-northeast.



Figure 32: Horsethief Creek site showing the change in elevation topography south of US-97.



Figure 33: North of US-97 at Horsethief Creek proposed site looking east-southeast.



Figure 34: Looking south over US-97 at Horsethief Creek proposed mitigation site.



Figure 35: The downhill, below grade, elevation change at the Horsethief Creek site looking east.

8.2.3. Site 3: Mud Lake



Figure 36: Mud Lake A proposed site looking west-southwest along US-97.



Figure 37: Mud Lake A looking northwest over US-97.



Figure 38: Habitat at Mud Lake A looking south-southwest.



Figure 39: Standing on the embankment west of US-97 at the Mud Lake B site looking north.



Figure 40: Overlooking US-97 at the Mud Lake B proposed site looking east.



Figure 41: Below grade road alignment at Mud Lake B looking south-southwest.



Figure 42: Below grade road alignment at Mud Lake B looking north-northwest.

8.2.4. Site 4: Grass Lake Summit



Figure 43: Grass Lake Summit proposed site looking south towards Mt. Shasta.



Figure 44: Standing on embankment at Grass Lake Summit site looking east over US-97.



Figure 45: Grass Lake Summit site looking north-northeast along US-97.



Figure 46: Highest elevation point at Grass Lake Summit site looking south-southwest along US-97.



Figure 47: Standing on eastern embankment at the Grass Lake Summit site looking north over US-97.

9. APPENDIX B: SUMMARY OF PRELIMINARY VIRTUAL DESIGN LAB RESULTS

This appendix includes preliminary results from the virtual design lab (VDL) that focused on the application of FRP materials to a wildlife overpass and associated design elements.

9.1. FRP Wildlife Infrastructure Elements

Opportunities for the integration of a variety of FRP materials into the structural design of a wildlife overpass structure and its related wildlife crossing design elements have been organized based on discussions among experts and Caltrans personnel in the VDL.

9.1.1. Substructure: Footings

The use of FRP CT girders for the superstructure will be lighter than normal steel plate girders or prestressed concrete girders which may permit reduced load calculations for footings and other foundation design elements.

- *Enhanced:* For reinforced concrete will be used for footing or drilled piles, then the use of FRP reinforcement can be explored in place of black iron, stainless-steel, or epoxy-coated rebar.
- *Innovative:* If skin friction is not an issue in the geologic properties at the crossing location, then the use of FRP tubes may be considered for drilled piles' casing.

9.1.2. Substructure: Abutments

There are numerous abutments and wingwall designs available. They include, but are not limited to, poured concrete, mechanically stabilized earth (MSE), and bin wall designs. The abutment type influences what applications of FRP materials is possible.

- *Basic:* Abutments can be wrapped in FRP to protect the surface from environmental factors and increase the service life of the structure.
- *Basic:* Recycled plastic FRP material can be used in non-structural applications in place of large boulders or stones.
- *Enhanced:* For poured concrete abutments, the use of FRP reinforcing in place of black iron, stainless-steel, or epoxy-coated rebar can be considered.
- *Enhanced:* For MSE walls, there may be some possibilities to consider and explore the use of FRP strapping or FRP geotextile style mat.
- *Innovative:* The use of FRP abutment casings can be installed quickly prior to filling them with concrete. This casing can provide shorter construction times and increased service life compared to traditional wrapping methods, because the concrete will be protected from environmental elements on all sides.
- *Innovative:* FRP panels, or systems, may be able to be used for bin wall designs.

9.1.3. Superstructure: CT Girders

The WTI Team has conducted a scan of North American FRP manufacturers to assess their suitability to a wildlife crossing project. AIT's CT girder system is one of the few manufacturers capable of building a wildlife crossing of this scale. The girders in this section focus on the use of

a FRP tub girder, and do not evaluate all the manufactures capable of building the 115 ft bridge span.

- *Basic*: The CT girder system is a closed-top hollow FRP tub girder that is simply supported on standard foundations with a pre-cast, or cast-in-place concrete deck.
- *Enhanced*: Filling the negative space within the tub girders is one enhancement that could be applied to an existing CT girder system. Tub girders filled with foam, or other lightweight materials, could provide sound attenuation from traffic underneath without dramatically increasing the weight of the girders.
- *Innovative*: Sections on the top of the CT girder can be left open to create planting pockets. These openings would provide more space for vegetation with deeper root development without increasing the depth of the soil across the entire structure. Additional research is required to assess the structural impacts from the openings in the concrete deck, as well as the evaluating the effects of moisture and rooting stress to the structural properties of the CT girder.

9.1.4. Superstructure: Deck

A precast concrete deck is the standard design used for the CT girders. It adds compressive strength to the structure and provides additional sound attenuation. Alternate materials have been identified to offset the ecological impact of concrete including the use of recycled materials such as crushed glass, fly ash, or ferrous concrete, and lightweight concretes have been developed and used in bridge decks.

- *Basic*: FRP reinforcement can be used in place of black iron, stainless-steel, or epoxy-coated rebar.
- *Innovative*: Recycled FRP aggregates (e.g., crushed wind turbine blades) could be integrated into the concrete mix to reduce the weight and increase the sustainability of the deck.
- *Innovative*: Use thin FRP panels as the subframe forms to connect CT girders. Concrete can be poured directly onto these panels, reducing the overall weight of the bridge span and accelerate bridge construction.
- *Innovative*: Incorporate bubble deck technology with FRP or recycled plastic spheres. A bubble deck incorporates air-filled balls into the reinforced concrete deck to reduce the decks weight.
- *Innovative*: A deck composed entirely of FRP. An FRP decks can be installed before or after the girders are put into place to reduce weight of the bridge span and decrease construction time.

9.1.5. Superstructure: Aesthetics

A huge benefit to using FRP materials for making a wildlife crossing structure more aesthetically pleasing, is the highly versatile and customizable properties of the composites. Designers can mold, carve, build, infuse, form, or 3-D print anything imaginable that can be connected to the side of the superstructure. This means that detailed aesthetic architecture can be constructed simultaneously during bridge construction and installed quickly.

- **Basic:** Any FRP aesthetic architecture that is installed to the side of the bridge superstructure without decreasing bridge strength or safety properties. False sides in the form of a facade or appliques, of wildlife or other images, could be cast in FRP and attached to the structure's sides for architectural interest. The color customization of FRP could also be leveraged to blend into the surrounding landscape or to draw attention to the structure.
- **Basic:** The CT girders can have pigment added to them during manufacturing.
- **Enhanced:** FRP impact absorbers can be designed and installed to the side of the outer CT girders to reduce damage from an underside strike from vehicular traffic.
- **Enhanced:** Side members could be added to act as a false front to create the illusion of a more elegant structure such as an arch.

9.1.6. Corridor: Fencing and Jump-outs

Wildlife crossings need to be built with exclusionary fencing to guide the animals to the overpass and keep them off the road. FRP composites can be a direct replacement to traditional materials, including wood, steel, and concrete.

- **Basic:** Conventional exclusionary fencing is constructed using wood and/or steel elements. Wood fencing typically has a life cycle of 20-30 years.
- **Enhanced:** The use of FRP posts to replace wood or steel in wire mesh wildlife fencing. They are installed the same way as traditional materials and could result in a longer life span and with lower maintenance requirements.
- **Enhanced:** Pultruded FRP boards can be used to replace wood in traditional wildlife jump-out designs.
- **Innovative:** Replace wire mesh with an FRP mesh design.

9.1.7. Corridor: Sound and Light Barriers

These barriers vary from fence designs because they are built to block sound and light from penetrating the animal's field of view. Side treatments on the crossing structure assumes that some form of sound and light attenuation is required to shield the surface of the overpass from traffic

- **Basic:** Barriers are commonly made from concrete, wire mesh fence, soil berms, and other traditional applications.
- **Enhanced:** FRP façade/panels on side of structure could be incorporated into the architectural design of the structure negating need for additional aesthetic panels, fences, etc.
- **Enhanced:** Barriers can be constructed with pultruded boards or foam core structures.
- **Enhanced:** To replace wire mesh fencing, FRP grates and/or fence posts can replace traditional steel elements.

9.2. Environmental Landscaping

The top surface of the bridge is important in guide animals' use of the wildlife overpass. The type of landscaping is influenced by the target species and guided by the overall project goals. In general, WVC safety concerns are addressed with exclusionary fencing. The primary purpose of the crossing structure is to provide connectivity for the focal species. The crossing structure also

offers an opportunity to create an environment conducive to the movement of other local species. The integration of elements beyond those required for conveyance of species of safety concern contributes to the overall ecological function of the structure to integrate into the surrounding environment. It is generally recommended that the landscape surface on a crossing structure reflects the surrounding environment in terms of habitat conditions and species composition.

The primary concern at the US-97 site is motorist safety, however strategic planting and design on the landscape surface can facilitate the movement of local species beyond those that pose a safety concern. For example, small species take longer to move across a structure and thus require additional habitat elements (e.g., hiding cover, water, food) to encourage use of structure.

The effects of replacing the natural materials commonly used with artificial FRP elements is unknown. They should be used on an experimental basis and monitored alongside natural materials to assess animal use and integration into the environment. Because of these factors, most of the environmental design lab focused on the planting strategy, back-fill, and draining strategies, which are reflected in the WTI Team's structural design in the next chapter.

9.2.1. Environmental Parameters

There are countless ways to design the environmental landscape of the crossing structure. The US-97 mitigation site was used to guide the design lab's efforts of meeting the goals of the mitigation site, while adapting FRP composites into landscaping elements.

- *Safety*: The primary species of safety concern at the project site are black tailed deer and elk.
- *Connectivity*: Smaller wildlife species spend more time on a crossing structure, thus additional resources and basic life requisites are needed to support their movement
- *Drainage*: Water does not need to be retained on top of the structure and should be properly drained.

9.2.2. Surface and Approach: Substrate & Fill

The type of materials used for the substrate of the wildlife crossing determines the types of vegetation that can be planted on the structure. The species selected for landscaping are affected by both the depth and type of soil. The following options have been identified as suitable options for the surface: gravel; scree-type gravel mix, volcanic rock, engineered soils, and soilless mix (e.g., vermiculite and perlite). No plastics will be used in the soil mix.

- *Basic*: Back-fill is 100% natural materials
- *Enhanced*: Geofoams can be used in place of back-fill on the approach
- *Enhanced*: Large blocks made from recycled plastic can be used to replace back-fill on the approach.

9.2.3. Surface and Approach: Landscape Materials

It is preferred to use local species that are harvested in the area rather than the integration of cultivars, due to adjacent Forest Service lands. The use of native species is recommended with a focus on those present in the surrounding landscape to maximize the chances of success. Local

live plants should be retained during overpass construction to the extent possible to replant on overpass.

- *Basic*: Only natural materials are used.
- *Enhanced*: Build planters using FRP boards.
- *Enhanced*: FRP can be molded to replicate rocks and other hiding material.
- *Innovative*: Create FRP trees for hiding cover and to mimic trees for smaller animal movements.



Nevada Department of Transportation

Kristina L. Swallow, P.E. Director

Ken Chambers, Research Division Chief

(775) 888-7220

kchambers@dot.nv.gov

1263 South Stewart Street

Carson City, Nevada 89712