

NDOT Research Report

Report No. 342-20-803

**TPF-5(358)
RESEARCH TO INFORM PASSAGE SPACING FOR
MIGRATORY AMPHIBIANS AND TO EVALUATE
EFFICACY AND DESIGNS FOR OPEN ELEVATED
ROAD SEGMENT (ERS) PASSAGES**

July 2022

**Nevada Department of Transportation
1263 South Stewart Street
Carson City, NV 89712**

Contributing Partners

**Alaska DOT
ARC Solutions, Inc.
Arizona DOT
California DOT
Iowa DOT
Ontario Ministry of Transportation
Oregon DOT
Michigan DOT
Minnesota DOT
New Mexico DOT
Parks Canada
Washington DOT**



**In Cooperation with
USDOT Federal Highway Administration**

Disclaimer

This work was sponsored by the Nevada Department of Transportation. The contents of this report reflect the views of the authors, who are responsible for the facts and the accuracy of the data presented herein. The contents do not necessarily reflect the official views or policies of the State of Nevada at the time of publication. This report does not constitute a standard, specification, or regulation.

TECHNICAL REPORT DOCUMENTATION PAGE

1. Report No. 342-20-803	2. Government Accession No.	3. Recipient's Catalog No.	
4. Title and Subtitle Research to Inform Passage Spacing for Migratory Amphibians and to Evaluate Efficacy and Designs for Open Elevated road Segment (ERS) Passages		5. Report Date July 2022	
		6. Performing Organization Code	
7. Author(s) Cheryl Brehme, Stephanie Barnes, Brittany Ewing, Cassie Vaughan, Michael Hobbs, Charles Tornaci, Philip Gould, Sarah Holm, Hanna Sheldon, and Robert Fisher		8. Performing Organization Report No. IP-142380	
9. Performing Organization Name and Address Western Ecological Research Center U. S. Geological Survey 4165 Spruance Road, Suite 200 San Diego, CA 92101-0812		10. Work Unit No.	
		11. Contract or Grant No. P342-20-803	
12. Sponsoring Agency Name and Address Nevada Department of Transportation 1263 South Stewart Street Carson City, NV 89712		13. Type of Report and Period Covered Final Report September 2020 to June 2022	
		14. Sponsoring Agency Code	
15. Supplementary Notes			
<p>16. Abstract</p> <p>This research was conducted to; 1) help inform the distances required between crossings to provide high permeability across roads for migratory amphibians (i.e., Yosemite toad), 2) to assess the permeability of a new passage design for amphibians and other small animal species, and 3) to provide engineering evaluation of this concept for primary roads and highways.</p> <p>1) Although the sample size was low due to severe drought conditions in the last two years of the study and sampling constraints, we found similarities between the fence movement behavior of Yosemite toads and other migratory amphibians. Approximately 90% of toads were estimated to move 20 m or more along the fence, with an average distance of 46 m before "giving up". These preliminary results suggest that passages spaced within 20m of one another along Yosemite toad migratory pathways are likely to provide connectivity to 90% of the population.</p> <p>2) Initial results of passage permeability showed that the elevated road segment (ERS) crossing has a high potential to provide increased connectivity for Yosemite toads and a wide range of other amphibian, reptile, and small mammal species while greatly reducing road mortality.</p> <p>3) The ERS concept designs, engineering evaluation and guidance document for primary roads and highways provide a starting point for local and DOT engineers to design and build permanent ERS structure(s) to enhance the movement of small wildlife, particularly for, but not limited to, migrating amphibians over wide stretches of roadway.</p>			
17. Key Words Wildlife passage, amphibians, reptiles, small mammals, road fencing, passage design		18. Distribution Statement No restrictions. This document is available through the: National Technical Information Services Springfield, VA 22161	
19. Security Classif (of this report) Unclassified	20. Security Classif (of this page) Unclassified	21. No. of Pages Click or tap here to enter text.	22. Price n/a

Research to Inform Passage Spacing for Migratory Amphibians and to Evaluate Efficacy and Designs for Open Elevated Road Segment (ERS) Passages.



Research to Inform Passage Spacing for Migratory Amphibians and to Evaluate Efficacy and Designs for Open Elevated Road Segment (ERS) Passages.

Cheryl S. Brehme¹, Stephanie Barnes², Brittany Ewing¹, Cassie Vaughan², Michael Hobbs³, Charles Tornaci⁴, Philip Gould¹, Sarah Holm⁴, Hanna Sheldon⁴, and Robert N. Fisher¹

¹U.S. GEOLOGICAL SURVEY, WESTERN ECOLOGICAL RESEARCH CENTER

²U.S. FOREST SERVICE

³HOBBS ECOLOGY

⁴DOKKEN ENGINEERING

Original project entitled “Research to inform passage spacing for migratory amphibians and to evaluate the effectiveness of an elevated road segment to reduce road mortality and maintain connectivity between wetlands and uplands: Case study with the Yosemite toad”

Collaborator Report Prepared for:

Nevada Department of Transportation

Transportation Pooled Fund Program Project P342-20-803

Research authorized by:

U.S. Fish and Wildlife Service, 10(a)1(A) Recovery Permit TE-045994-18

California Department of Fish and Wildlife, Scientific Collecting Permit (Entity) and MOU: SCP838

San Diego Field Station
USGS Western Ecological Research Center
4165 Spruance Road, Suite 200
San Diego, CA 92101

Suggested Citation: Brehme, C., Barnes, S., Ewing, B., Vaughan, C., Hobbs, M., Tornaci C., Gould, P., Holm S., Sheldon H., and R. Fisher. 2022. Research to Inform Passage Spacing for Migratory Amphibians and to Evaluate Efficacy and Designs for Open Elevated Road Passages. USGS Cooperator Report to Nevada Department of Transportation, Transportation Pooled Fund Program Project P342-20-803.

Any use of trade, firm, or product names is for descriptive purposes only and does not imply endorsement by the U.S. Government.

Table of Contents

Introduction	1
Background	3
Fence Movement Distances and Behavior.....	3
Yosemite Toad	4
Elevated Road Segment	5
Research Questions/ Goals	6
Methods	9
Field Study	9
Analysis.....	11
Concept Designs for Elevated Road Segments on Primary Roadways	17
Results	18
Fence Movement- Yosemite Toads	18
ERS Passage Permeability- Yosemite Toads	23
ERS Passage Permeability- All Small Animal Species	23
Concept Designs for Elevated Road Segments on Primary Roadways	28
Discussion	28
Research to Inform Passage Spacing for Migratory Amphibians: Yosemite Toad	28
Elevated Road Segment Permeability	30
Concept Designs for Elevated Road Segments on Primary Roadways	31
Considerations for Future Studies	32
Acknowledgements	33
Literature Cited	34
Appendix 1: Supplemental Tables for ERS Activity Analyses	38
Appendix 2: Elevated Road Engineering Concept Designs and Guidance for Primary Roads and Highways	41

Tables

Table 1. Yosemite Toad Movement Metrics by Fence Type and Age Class	19
Table 2. Probability of Reaching Underpass by Initial Location, Direction of Travel (Toward or Away from Passage), and Fence Type.	21
Table 3. Total Numbers of Photos from all Cameras by Species and Year (after removal of repeat detections within 30 min time window used for analysis)	24
Table 4. Effect of location on the relative activity of amphibians, small mammals, and reptiles. Mean estimates and 90% confidence intervals are presented for 3 locations: 1) within the underpass (Under ERS), 2) immediately adjacent to the underpass and roadway (Adjacent to ERS), and 3) in the forest (Outside ERS).	26

Figures

Figure 1. Diagram and Photos of Elevated Road Segment.....	6
Figure 2. Maps of A) Yosemite Toad Road Mortality and B) Location of Barrier and Elevated Road Crossing in Sierra National Forest Between Upland and Breeding Habitat.	9
Figure 3. Schematic of Elevated Road Segment, Mesh Fencing (Dotted Lines), Solid Fencing (Lines), HALT Cameras (Circles), and Time Lapse Cameras (Black Circles); Not to Scale.	10
Figure 4. Solid (A) and Mesh (B) Fence Lines. Along the Fences are Jump Outs and Cameras within Plastic Bins Facing Down Toward HALT Triggers.....	11
Figure 5. Example of Yosemite Toad Identified to Individual Using i3s Software to Distinguish Spot Patterns.	12
Figure 6. Logistic Regression for Success in Reaching Underpass Opening.....	13
Figure 7. Gamma Regression for Distance Moved Along Fence	14
Figure 8. Distributions of Movement Distances A) by Fence Type and B) Overall. Lines Represent Mean (solid black), Median (dashed black), and lower 90% Tolerance Interval (red dotted).	19
Figure 9. Yosemite Toad Movements by Fence Type and Age Class, A) Movement Distances and B) Distribution of Initial Encounter locations.	20
Figure 10. Movement Distance by Initial Location and Direction of Travel with 50%, 75%, and 90% Confidence Intervals, A) Toads Initially moving Toward Passage and B) Toads Initially moving away from passage.....	20
Figure 11. Probability of Reaching Underpass by Initial Location and Direction of Travel (Toward or Away from Passage) with 90% Confidence Intervals.	22

Research to Inform Passage Spacing for Migratory Amphibians and to Evaluate Efficacy and Designs for Open Elevated Road Passages.

Introduction

This is a multifaceted project that includes three main areas of research targeted to inform effective crossing systems for migratory amphibians, a large group of species which are at very high risk from negative impacts from roads within their habitats (Glista et al. 2008, Hamer and McDonnell 2008, Semlitsch 2008, Brehme et al. 2018). The three projects presented in this report are:

- 1) Movement distances along road barrier fencing and probabilities of reaching a passage: Case study with Yosemite toads (*Anaxyrus canorus*) in Sierra National Forest, CA.
- 2) Effectiveness of a novel elevated road segment (ERS) road passage system prototype in providing connectivity for amphibians, reptiles, and small mammals: Case study in Sierra National Forest, CA.
- 3) Concept designs and transportation engineering evaluation for the ERS on primary roads and highways.

This research began in 2018 as part of a larger U.S. Geological Survey (USGS) research program in collaboration with the U.S. Forest Service (USFS), California Department of Transportation (Caltrans), and Western Transportation Institute (WTI; Montana State University) to inform best management practices for barrier and crossing systems for sensitive amphibians and reptiles in California (Langton and Clevenger 2021, Brehme and Fisher 2020). The funding from Department of Transportation (DOT) pooled fund partners (Parks Canada / Government of Canada, Federal Highway Administration (FHWA), U.S. State Departments of Transportation (AK, AZ, CA, CO, IA, MI, MN, NM, NV, OR, WA), Ontario Ministry of Transportation) and managed by the Nevada Department of Transportation (NDOT) supported 2021 field study efforts, analyses of fence movement distances for Yosemite toads, and analysis of the efficacy of a novel ERS passage system to Yosemite toads and other amphibians, reptiles and small mammals. Finally, this pooled fund project includes an assessment by transportation engineers in consultation with USGS and Caltrans to provide insight, guidance, and concept designs for similar crossing solutions that could be implemented on improved roads.

This research is meant to inform the distances required between crossings to provide permeability for migratory amphibians (i.e., to allow movements necessary for population persistence across roads) as well as to assess the permeability of a new passage design for amphibians and other small animal species that may provide greater connectivity and offer an

alternative to below grade tunnels. The results of these studies add to the current body of knowledge in road ecology and increase the choices of road passage designs for amphibians and other small wildlife species.

Background

Amphibians have been identified as particularly susceptible to the negative effects of roads within their habitats (e.g., Forman et al. 2003, Rytwinski and Fahrig 2012, Andrews et al. 2015a, 2015b). Many are slow moving, do not avoid roads, and are simply too small for drivers to avoid. During rains many amphibians make long linear terrestrial movements regardless of the presence of intersecting roadways (Glista et al. 2008). In particular, pond breeding amphibians use both aquatic and terrestrial habitat to complete their life cycles (i.e., breeding, development, foraging, and overwintering), and therefore, require connectivity for making movements necessary for population persistence within and between aquatic and terrestrial habitats to support basic life history requirements. Increased mortality of amphibian populations from vehicles using roads that intersect breeding and upland habitat, if significant, can result in reduced population sizes and increased probability of extirpation (e.g., Hamer and McDonnell 2008, Semlitsch 2008, Brehme et al. 2018, Ottburg and van der Grift 2019). To synthesize what was currently known about reptile and amphibian crossing systems in California and throughout the world and to identify primary information gaps in scientific and practical knowledge to inform these crossing systems, WTI conducted a detailed literature review and synthesis with input from USGS (Langton and Clevenger 2017). The authors reviewed 52 studies on crossing systems with 125 individual taxa (75 reptile and 50 amphibian species or sub-species) throughout Europe, North America, South America and Australasia. Of these studies, 45% were for reptiles and 55% for amphibians. Information from each paper was summarized into three study or ‘knowledge area’ categories: passage construction and use, passage environmental variables, and barrier construction and use.

Langton and Clevenger (2017) concluded that in most cases road mitigation was installed primarily to reduce road mortality versus to maintain connectivity. However, large passages tended to be more permeable to amphibian and reptile crossings than smaller passages. They determined that the literature reflected a widely spread and low-inference scientific knowledge base regarding the efficacy of amphibian and reptile passages and barrier systems. They concluded there was a need for more properly designed studies to evaluate the effectiveness of purpose-built (engineered) and non-engineered passages and barriers. Research studies (controlled experimental or field settings) were needed to directly measure, test and compare results among mitigation structures, their structural and environmental characteristics, and permeability to species and species groups.

Fence Movement Distances and Behavior

Currently, there are a lack of data available to inform decisions about the number of crossings and spacing between crossings for migratory amphibians. There is some evidence that road mitigation systems with passages spaced too far apart may filter or reduce migratory movements of pond breeding amphibians (e.g., Langton 1989, Allaback and Laabs 2002, Ottburg and van der Grift 2019). Although amphibians may migrate large distances to natal breeding ponds, new research is revealing that many move relatively short distances back and forth along

road barrier fencing before “giving up”. For instance, individuals from a population of the common toad, *Bufo bufo*, migrating to their breeding habitat in the Netherlands moved back into the upland habitat or “gave-up” after an average of 40 m if they did not reach a tunnel passage (Ottburg and van der Grift 2019). The passages were spaced 100 m apart. The authors considered this the main factor causing a steep population decline in the five years after the tunnel and barrier system was installed.

Similarly, a recent study led by USGS using active infrared trigger cameras (Hobbs and Brehme 2017), found that migrating adult California tiger salamanders (CTS) also moved an average of 40 m along barrier fencing before turning back into the habitat or “giving up”. By tracking individuals and modeling the probability of successfully reaching a passage, the authors suggested that a maximum of 12.5 m between passages along CTS migration routes would likely allow approximately 90% of adult salamanders to encounter road crossings.

Many different types of road barrier fencing with varying opacity have been used for herpetofauna, and there is some evidence that animals may spend more time interacting with transparent fencing than with solid fencing (Ruby et al. 1994; Milburn-Rodriguez 2016, Brehme and Fisher 2020, Brehme et al. 2021). Thus, fence materials may be an important factor in the speed and probability that migrating amphibians may reach a road passage. The extent of these and other factors on the efficacy of road barrier and crossing systems and species is largely unknown.

Yosemite Toad

Bufoiid toads can move large distances (>1 km) in both aquatic and terrestrial habitats to breed, feed and overwinter, and there is evidence that bufoiid toads are particularly susceptible to negative impacts from roads (Trenham et al. 2003, Orłowski 2007, Eigenbrod et al. 2008). Endangered and threatened species are considered at risk of extirpation, often due to multiple stressors, and are thus thought to be less likely to be resilient to additional road impacts. Because of these attributes, the Yosemite toad (*Anaxyrus canorus*), which is federally listed as threatened (USFWS 2014) ranked in the highest risk category for susceptibility to negative road impacts in a recent road risk assessment of 166 species of reptiles and amphibians in California (Brehme et al. 2018).

The Yosemite toad is a relatively long-lived toad (12–15 years) that inhabits high elevation, open, montane meadows, willow thickets, and adjoining forests in the Sierra Nevada, California (Liang and Stohlgren 2011, USFWS 2014). This species breeds in shallow edges of snowmelt pools and ponds or along edges of lakes and slow-moving streams. Females may breed every other year or once every three years and some breeding sites dry up before larvae metamorphose (USFWS 2014). Although still distributed over most of its original range with many populations actively breeding and recruiting, the species has declined or disappeared from more than 50% of the sites from which it has been recorded (Jennings and Hayes 1994, Drost and Fellers 1996, Shaffer et al. 2000, Brown et al. 2012, USFWS 2014). Hypotheses for the declines include habitat loss and degradation, disease (chytridiomycosis), airborne contaminants,

livestock grazing, drought, fish predation, raven predation, road mortality and vehicle vibration effects (e.g., Hammerson et al. 2004, Davidson and Fellers 2005, USFWS 2014).

Currently, data to inform the number and spacing of road crossings for Yosemite toad are generally lacking. In 2017, the USFS, Sierra National Forest reported 126 Yosemite toads that had been run over and killed by vehicles on Forest Service roads. Of these, 92 subadults were found on the 9S09 road between June 24 and October 24. The USFS and U.S. Fish and Wildlife Service are particularly concerned about the potential for increased Yosemite toad road mortality due to increased vehicular traffic projected for these roads in the future and sought information on effective mitigation to reduce road mortality and maintain connectivity for this species.

Elevated Road Segment

A common road mitigation strategy for amphibians is to install small tunnels or culverts under the roadway at road mortality “hot spots”. Fencing is used to prevent animals from going out onto the roadway and to funnel them toward the small passage(s). The life history and behavior of many migratory amphibians, including the Yosemite toad, present a challenge to this common mitigation strategy. Many have been shown to travel in straight line trajectories over wide areas, resulting in long lengths of roadways where they are susceptible to road mortality without any clearly defined “hot spots” (e.g., Pacific Newt Roadkill Project 2022, Vaughan et al. in prep)

Sierra National Forest Road 9S09 is on a flat landscape, with an upland slope on one side and downward slope on the other. Burrowing passage(s) under the road would require a significant amount of grading and re-contouring on the upland slope side to make passage entrances accessible. To meet these challenges, in June of 2018, the USGS and USFS designed and installed a novel 30 m (100 ft) long road crossing structure in a high road mortality section of 9S09 (Figure 1). The crossing structure is an elevated roadway segment (ERS) placed on top of the existing road surface and is composed of hardwood laminated billet road mats that are designed for use by heavy equipment at construction sites (Emtek®). The road mats are approximately 6 in. thick and were installed on top of 8-in. high support bars installed on and perpendicular to the road, allowing for passage of small animals. In addition, the ERS is permeable to light and rainfall, allowing for a wetted passage for amphibians moving during rainfall events. It was built to meet codes and specifications for USFS, County, and City roads and can theoretically be built to any length or at increased heights depending upon the size of the supports used.

A)

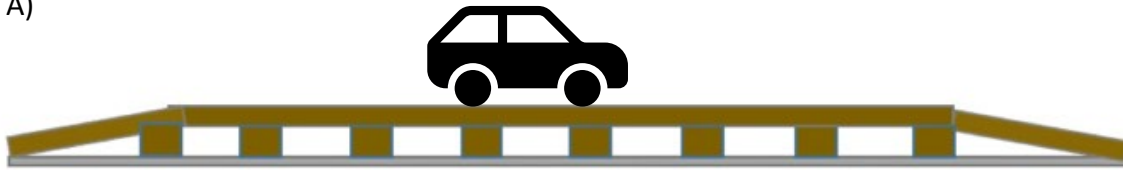

B)



Figure 1. Elevated Road Segment (A) Diagram and (B) Photos; side diagonal view (left), vehicles driving on top of ERS (top-right), side view showing road surface and underneath ERS (bottom-right).

Research Questions / Goals

Movement Distances along Road Barrier Fencing and Probabilities of Reaching a Passage: Case Study with Yosemite toads in Sierra National Forest, CA.

The distance Yosemite toads may travel along a barrier fence to find a passable crossing was unknown. Therefore, a study was warranted to determine toad movement distances along barriers to inform proper passage spacing for the Yosemite toad. We were also interested in whether

fencing opacity affects the probability or speed at which the toads find wildlife crossings. The results of this study will help to identify underpass spacing needs and evaluate barrier materials for Yosemite toads and similar species.

Research Questions:

- 1) What is the probability a Yosemite toad will reach an underpass based upon the distance from the underpass an animal first encounters the barrier wall?
- 2) How quickly do toads travel along the barrier wall toward the crossing structure?
- 3) How does the opacity of fencing affect the questions above?
 - a. Solid barrier (high-density polyethylene (HDPE-2; Animex®))
 - b. Semi-transparent barrier (water- permeable rigid polymer matrix; ERTEC® E-Fence, referred to hereon as “mesh”)
- 4) How does movement distance vary by age/size class?
- 5) Is the ERS effective in reducing road mortality while maintaining connectivity between breeding wetlands and uplands for the Yosemite toad?

Effectiveness of a Novel Elevated Road Segment (ERS) Road Passage System prototype in providing Connectivity for amphibians, reptiles, and small mammals: Case Study in Sierra National Forest, CA.

The ERS installed on road 9S09 is a new passage design that was untested. Although the permeability of small animal species across the road surface is unknown, our goals were to assess under passage use in relation to the surrounding environment.

Research Questions:

- 1) What is the probability small animal species will move under the ERS?
- 2) What is the relative activity of small animal species under the ERS in comparison to the surrounding forest and road verge area?

Concept Designs and Transportation Engineering Evaluation of the ERS concept designs for application to primary roads and highways.

DOT partners expressed concern that the ERS crossing may not be workable for primary roadways and highways and requested an assessment of the feasibility of this prototype to county, city, state, and federal roads and requirements. Therefore, we sought a comprehensive assessment from transportation engineers (Dokken Engineering) with input from Caltrans to provide insight, guidance, and concept designs for similar crossing solutions that could be implemented on improved roads.

Methods

Field Study

We studied the movement of individual Yosemite toads adjacent to and under the ERS structure along 9S09 in Sierra National Forest, CA in the breeding seasons of 2018 through 2021. The road bisects a Yosemite toad breeding meadow and upland habitat (Figure 2). We also collected data on the relative activity of other amphibians, reptiles, and small mammals.

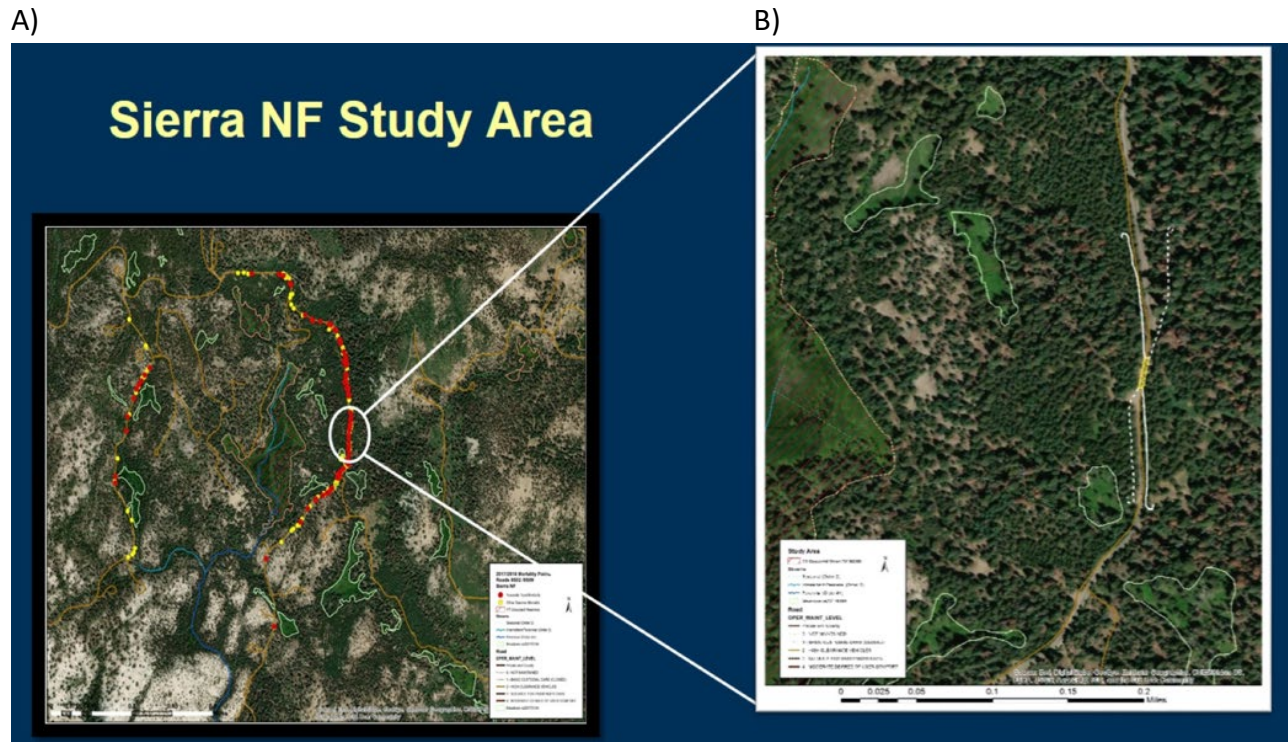

Figure 2. Maps of A) Yosemite Toad Road Mortality and B) Location of Barrier and Elevated Road Crossing in Sierra National Forest Between Upland and Breeding Habitat.

In 2018, approximately 480 m of barrier fencing was installed along the east and west sides of 9S09 (~120 m in each direction) connected to the ERS crossing. One portion of the fencing installed was semi-transparent (ERTEC® rigid polymer matrix E-Fence™) and the other portion was solid (Animex® high-density polyethylene (HDPE-2)). Jump-outs (ERTEC® cones and high berms) were installed a minimum of every 10 m along the fence to provide toads and other small vertebrates a way to get back into the habitat if they ended up on the road side of the barrier fencing. At outer fence ends, turnarounds were installed to redirect animals away from the road and back toward the upland habitat in a U-shaped fashion. The turnarounds were approximately 2 m long and 1 m in width. Fencing was installed with the bottom buried in the ground according to manufacturers' guidelines.

HALT® active-trigger camera systems (Hobbs and Brehme 2017) were placed against the fencing every 20 m along the new fence lines from 0 to 100 m from the ERS and at the end of fence end turnarounds (Figures 3 and 4). In 2021 and 2022, we added an additional camera between the 0 m and 20 m cameras (10 m). Each 0 m camera was approximately 8 m from the closest ERS opening to allow the cameras to be shielded from the view of forest visitors. Each year, cameras were set up on the wetland side as soon as possible after the road opened (spring) and were checked weekly to collect data on toads during their upland migration.

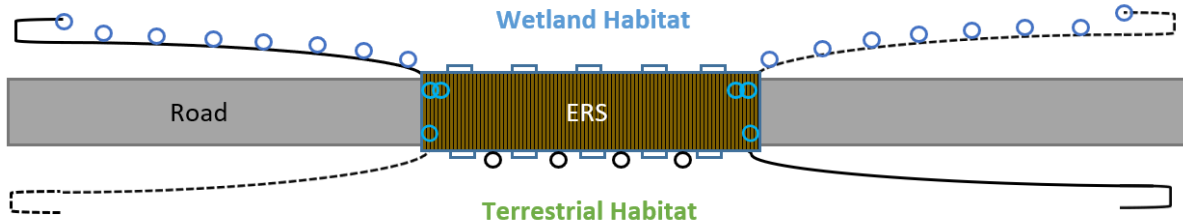

Figure 3. Schematic of Elevated Road Segment, Mesh Fencing (Dotted Lines), Solid Fencing (Lines), HALT Cameras (Circles), and Time Lapse Cameras (Black Circles); Not to Scale.

The width of the ERS underpass made it impossible to sample completely; therefore, we subsampled underpass activity in both space and time. For this, we placed 1-2 HALT camera systems under both ERS intersections with the fence line on the west (meadow) side to record tunnel entrances. Tunnel camera triggers were placed at least 1-2 feet deep into the passage on each side. Additional cameras and triggers were added within the same passages in 2020 and 2021 for better coverage. We included eight Reconyx cameras set to a time lapse of every 5 minutes on the upland side under the ERS to gather more data on animal movements.

Each time we set and checked the cameras, we took a photo of a battery powered atomic clock in order to calibrate exact minutes and seconds upon processing. All photos from the HALT cameras were reviewed and animals identified to species. Due to the extremely large number of time-lapse photos from Reconyx cameras, all photos were reviewed that were within 1 hour of any Yosemite toad HALT camera detection. Therefore, time lapse camera data was specific for Yosemite toad use.

All cameras were set as soon as the snow melted and road opened, and then checked on a weekly basis during the late spring and summer (May–Oct. 2018, July–Oct. 2019, June–Sept. 2020, May–Oct. 2021). Due to road closures during winter and spring months, we began monitoring upland toad movements immediately after snow melt and during the summer months when toads are typically active and moving during rainfall events. Total precipitation was approximately 30.6 in., 52.1 in., 24.3 in. and 17.0 in. for the rainfall years of 2018–2021. Total summer precipitation in nearby Huntington Lake during the monitoring periods was approximately 0.9 in. for 2018 (June–Oct.), 1.3 in. for 2019 (July–Oct.), 0.05 in. for 2020 (June–Sept.) and 0.7 in. for 2021 (May–Oct.) after the snow melt (California Nevada River Forecast Center https://www.cnrfc.noaa.gov/monthly_precip_2021.php). Summer seasons were

approximately 3.0 in. or more below average rainfall during these periods (Western Regional Climate Center 044176-5). Annual rainfall was below average for all years except in 2019. Breeding and recruitment were documented by USFS in 2019; however, we likely missed most of the upland dispersal at the site due to the extended period of snowpack through June and lack of access to the site during this time. 2020 and 2021 were extreme drought years that were 54% and 38% of normal, respectively.

In 2021, cameras were removed in September due the “Creek Fire”, which burned almost 400,000 acres in Sierra NF and right up to the edge of the Yosemite toad breeding meadow adjacent to our study site. After the fire, the USFS also removed a large amount of downed wood and debris next to the study area and close to the fence line. In addition to below normal rainfall, it is unknown how these factors affected Yosemite toad activity or the number of toads detected in both 2021 and 2022.

Road mortality surveys were conducted along 9S09 by the USFS (Vaughan et al. in prep).



Figure 4. Solid (A) and Mesh (B) Fence Lines. Along the Fences are Jump Outs and Cameras within Plastic Bins Facing Down Toward HALT Triggers.

Analysis

Movement along fence line

Photos of all Yosemite toads were analyzed using pattern recognition software to identify individuals by their unique spot patterns (I³S Spot; Van Tienhoven et al. 2007; Figure 5). Camera location, time, and direction of movement were recorded for each individual. Snout to vent length was measured with Program ImageJ (Rasband 1997–2018) using the 1 cm grids from the HALT trigger for calibration. No toads were individually matched among years, and we therefore considered individual movements among years as independent in the analysis.

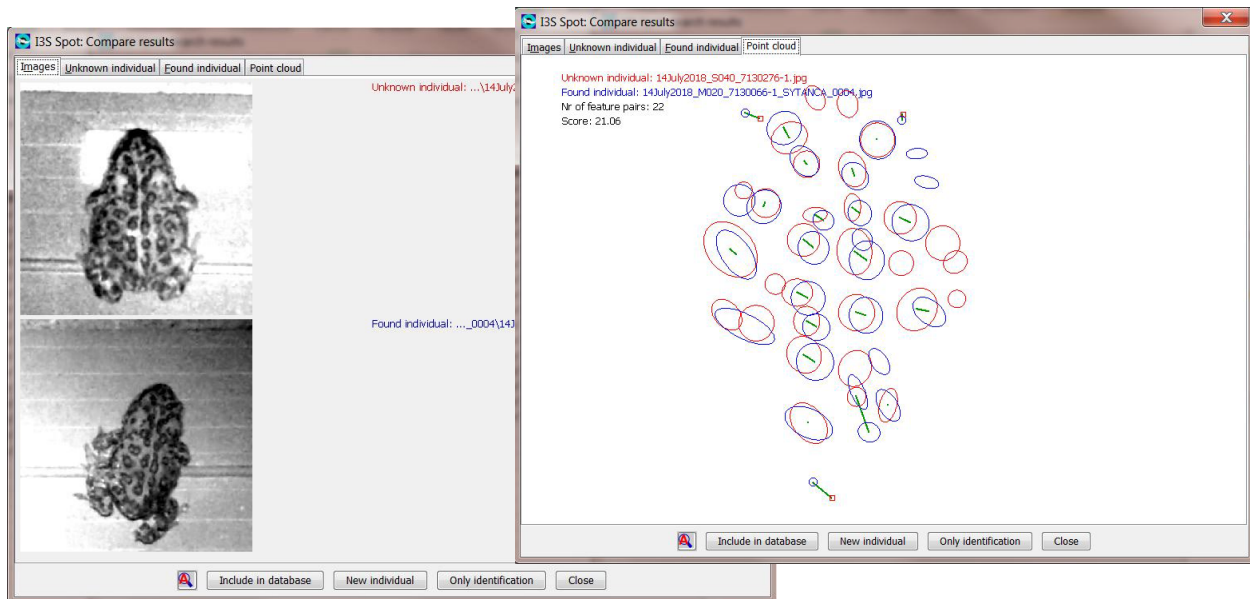

Figure 5. Example of Yosemite Toad Identified to Individual Using i3s Software to Distinguish Spot Patterns.

For individual Yosemite toads, we then calculated movement distances along the fence lines, numbers of turn arounds, speed, and “success” at reaching 0 m cameras next to underpass system. Because cameras were placed 20 m apart, our margin of error for estimating fence movement distance ranged between 0 and 20 m. For instance, if an animal was only detected at a single camera, then our average estimated distance was 20 m (10 m before reaching the camera and 10 m after exiting the camera). Similarly, if an individual was detected at multiple consecutive cameras moving in the same direction, our margin of error was typically 20 m. This margin of error was reduced to 10 m between the 0 m and 20 m cameras in 2021 after addition of a 10 m distance camera. In the instances where individuals were detected at consecutive cameras, we also calculated the movement speed between segments. If such an individual then turned around and was re-detected at a camera while moving in the other direction, we estimated the distance travelled along the fence before turning around by multiplying the time between detections by its average speed. Because of this, if individuals travelled back and forth several times, we were able to more accurately estimate the total distance of fence line traversed (fence movement distance). If an individual reached the 0 m camera (where the experimental fence lines attached to the short length of existing fence), this was considered a “success” at reaching the passage system with no added error for distance moved afterward. We used the R package ‘dplyr’ for computing summary statistics by Yosemite toad fence type and age class and the R package “tolerance” to compute the lower 90% confidence interval for movement distances across all Yosemite toads and years (Young 2010, R Core Team 2021, Wickham et al. 2022).

In general, for models of movement along fence line, we used Markov Chain Monte Carlo (MCMC) implemented in the R programming language and the runjags package to interface with JAGS (Just Another Gibbs Sampler) to sample values of all unknown parameters

from the joint posterior distribution (Denwood 2016). In each case, four chains were sampled to perform standard diagnostics for convergence. In all cases, non-informative prior distributions were used for all parameters.

Logistic Regression for Success in Reaching Underpass Opening

We modeled the probability of success of Yosemite toads in reaching the 0 m camera near the crossing opening. For this, we used a Bayesian approach to logistic regression modeling (Figure 6). The response was a Bernoulli random variable, where 0 indicates failure and 1 indicates success in being detected by the camera at the opening of the crossing (ReachedTunnel). The probability of success for the Bernoulli distribution was a logistic (i.e., $p = \exp(y)/(1 + \exp(y))$) function of the linear component of the model that consisted of four predictors (FenceType, InitLoc, InitAway, InitLocAway) and five parameters that include an intercept and a regression coefficient corresponding to each of the predictors. FenceType was a binary variable where 0 indicated a mesh fence and 1 indicates a solid fence. InitLoc was the position along the fence where the animal was first detected in meters from the crossing opening. InitAway was a binary variable where 0 indicated that the animal was initially moving toward the crossing and 1 indicated it was initially moving away from the crossing, and InitLocAway was an interaction (product of) InitLoc and InitAway. All non-binary predictors were standardized (the mean subtracted from each value and then divided by the standard deviation) prior to modeling. The priors for the parameters were non-informative normal distributions with mean 0 and 0.001 precision (i.e., a variance of 1000). The parameters were sampled from their posterior distributions using MCMC (as described above) and described by mean, median, and quantiles of their marginal distributions. This allowed us to assess the effect of each predictor on the probability of success.

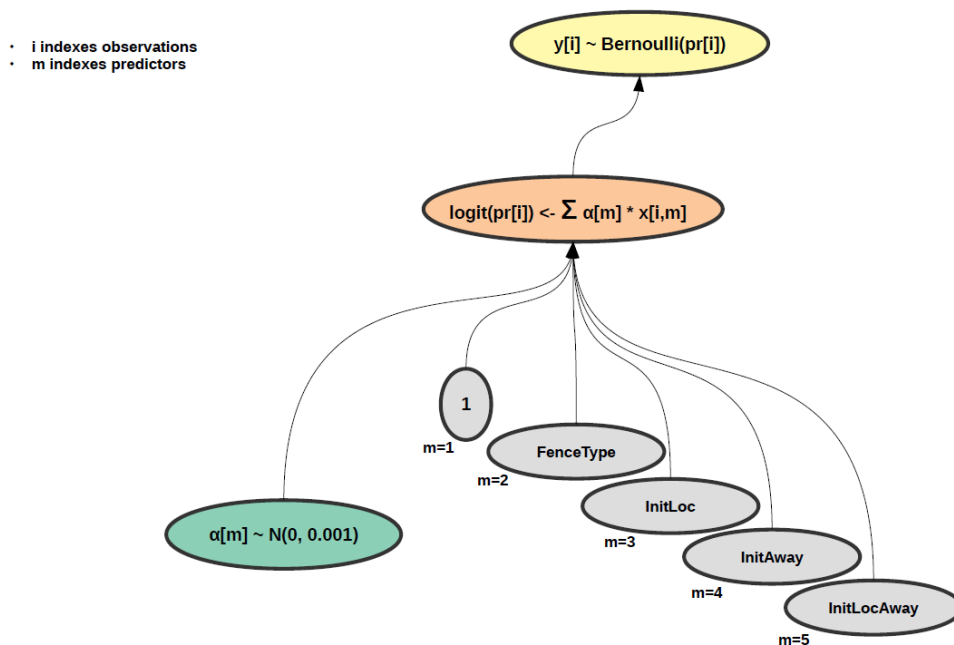

Figure 6. Logistic Regression for Success in Reaching Underpass Opening

Gamma Regression for Distance Moved Along Fence

We also modeled the distance that Yosemite toads moved along the fence (Figure 7). The response was assumed to be a gamma distributed random variable, which is a continuous positive variable representing the distance the animal moved along the fence. The gamma distribution has a shape parameter, which we assumed to be independent of any predictors, and a rate parameter that we model as an exponential (i.e., $\text{rate} = \exp(y)$) function of the linear component of the model that consists of four predictors FenceType, InitLoc, InitAway, ReachedTunnel, InitLocAway and six parameters that include an intercept and a regression coefficient corresponding to each of the predictors. All non-binary predictors were standardized prior to modeling. The prior for the shape parameter was a non-informative exponential distribution with a rate of 0.00001. The priors for the regression parameters for the rate were normal distributions with mean 0 and 0.001 precision (i.e., a variance of 1000). The parameters were sampled from their posterior distributions using MCMC (as described above) and described by mean, median, and quantiles of their marginal distributions. This allowed us to assess the effect of each predictor on the distance moved along the fence.

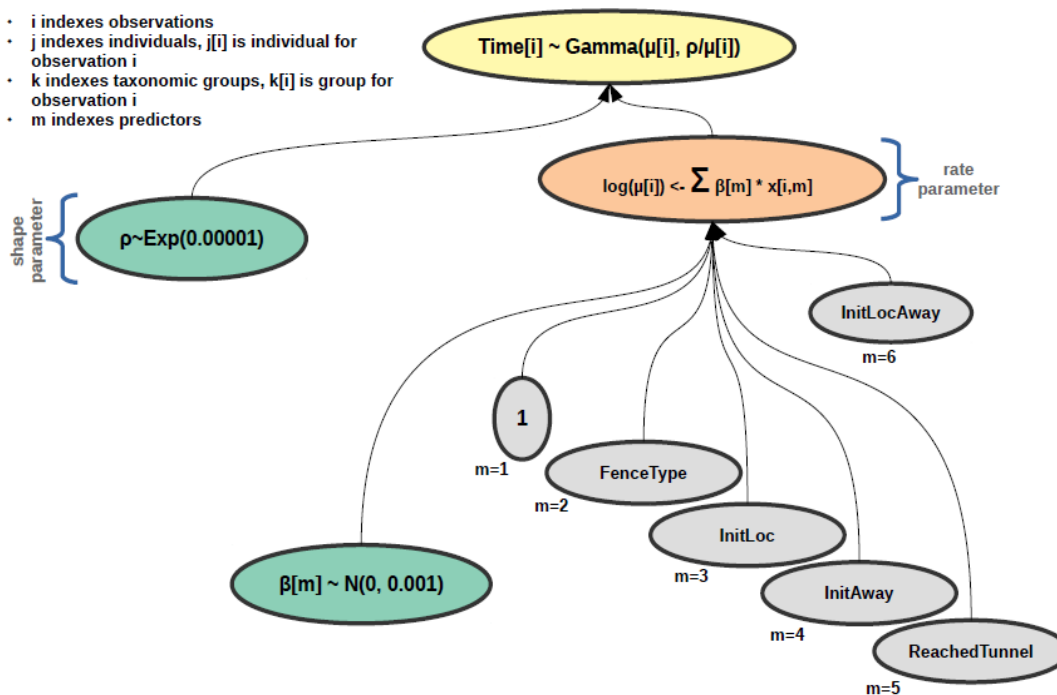

Figure 7. Gamma Regression for Distance Moved Along Fence

Elevated Road Segment Efficacy

To assess ERS crossing permeability for Yosemite toads, we analyzed the number of individual Yosemite toads monitored along the fence that reached the passage and were subsequently detected on a camera under the ERS. We also counted and report detections of toads that were detected under the ERS but not along the fence line. Because the cameras only sample a subset of the area under the ERS (due to extreme width), our reported results are an underestimation of use and would not have documented individuals using the passage that did not cross a camera trigger location.

To assess ERS crossing permeability for all species, results were analyzed by 3 general locations: 1) under the ERS passage, 2) immediately outside the ERS passage (within 0–28 m of passage and approximately <5 m from road), and 3) in the forest (>28 m from passage and approximately >5 m from road). We considered images to represent unique, independent use events when a minimum of 30 minutes had passed between the last unique observation of a species at a camera. We defined three 60-day secondary periods within each year and identified presence and abundance of use events during each secondary period and year. We considered species present during individual sampling periods if a single use event was detected (i.e., any activity). For the abundance model, species counts represent the sum of unique use events over the sampling period (i.e., measure of activity). Controlling for variation in temporal activity among seasons and years, occupancy and abundance are relative measures of proportion and frequency of space-use by each species (Gilbert et al. 2021) and represent general patterns in species activity across spatial and temporal gradients.

To analyze the use of the ERS by amphibians, reptiles, and small mammals, we modeled the presence and abundance of use events at each individual camera using open-population, community occupancy and N-mixture models with Bayesian inference (Kery et al. 2009, Yamaura et al. 2012, Gould et al. in review). Our observed data are y_{ijkt} , where y is the detection (occupancy) or count (N-mixture) of species k use events at camera i , during season j , in year t . Both the occupancy and N-mixture models include state and observation process models, to estimate the latent use probability and relative abundance of use events in each year, while accounting for imperfect detection (Mackenzie et al. 2005;2017, Royle and Dorazio 2008).

For community occupancy, the detection model for binary counts y_{ijkt} is defined:

$$y_{ijkt} \sim \text{Bernoulli}(z_{ikt} \times p_{ijkt} \times \text{bineffort}_{ij})$$

where z_{ikt} is the latent use of the detectable area around camera i , by species k , during year t ; p_{ijkt} is the probability that use is detected, and effort_{ij} is a binary term to remove any temporal replicates when cameras were inactive. We estimated latent use as:

$$z_{ikt} \sim \text{Bernoulli}(\Psi_{ikt})$$

where, Ψ_{ikt} is the camera use probability, which is estimated for each species, during each year. We allowed use probability to vary spatially and temporally by including covariates for

categorical camera location within station and a year-specific offset for each species. The logistic model for use probability is defined:

$$\text{Logit}(\Psi_{ikt}) = \beta_{0k} + \beta_{[location[i]]k} + \beta_{[year[t]]k}$$

where β_{0k} is the fixed, species-level intercept, $\beta_{[location[i]]k}$ is a matrix of random species-level intercepts for camera location, and $\beta_{[year[t]]k}$ is a matrix of random species-level intercepts determined by the year of observation. For both the location and year covariates, the first-level category, under-bridge and 2018, respectively, were set to zero for all species as a reference. The effects of camera location and year were specified as random effects with community-level hyperparameters for the mean and precision:

$$\begin{aligned}\beta_{[location[i]]k} &\sim \text{Normal}(\mu_{location[i]}, \tau_{location[i]}) \\ \beta_{[year[t]]k} &\sim \text{Normal}(\mu_{year[t]}, \tau_{year[t]})\end{aligned}$$

where μ is the community mean and τ is the community precision. The community mean estimates for camera location and year were specified with a normally distributed prior with a mean of 0 and a precision of 0.001. We estimated precision from standard deviation ($\tau = 1/\sqrt{\sigma^2}$), which was assigned a uniform prior between 0 and 10.

To model the observation process, we treated season j as temporal replicates within year t . We included a continuous effect of effort, corresponding to the number of days each camera was active during sampling period j . We also included categorical effects of season, resulting in the logistic model:

$$\text{Logit}(p_{ijkt}) = \alpha_{0k} + \alpha_{effort,k} \times \text{effort}_{ijt} + \alpha_{[cameratyp[e[i]]]} + \alpha_{[season[j]]k}$$

where α_{0k} is a fixed species-level intercept, $\alpha_{effort,k}$ is a random species-level effect of sampling days, $\alpha_{[cameratyp[e[i]]]}$ is a fixed offset of whether a camera was next to a fence, and $\alpha_{[season[j]]k}$ is the random species-level difference in detection between seasons. As before, random effects were drawn from community-level hyperparameters, with the same prior specification. The fixed effect of camera-type was specified as coming from a normal distribution with a mean of 0 and a precision of 0.001.

For the community N-mixture model, abundance is interpreted as frequency of use, and the detection model for counts y_{ijkt} is defined:

$$y_{ijkt} \sim \text{binomial}(p_{i,j,k,t} \times \text{bineffort}_{ijt}, N_{i,k,t})$$

where p and bineffort are the same as the occupancy model, and $N_{i,k,t}$ refers to the latent abundance of species k use events at camera i , during time t . Here we estimated latent abundance from a Poisson process:

$$N_{i,k,t} \sim \text{Poisson}(\lambda_{i,k,t})$$

where the Poisson rate parameter $\lambda_{i,k,t}$ represents the number of use events. We estimated $\lambda_{i,k,t}$ with a log link-function and the same covariate structure as the model for occupancy probability:

$$\log(\lambda_{i,k,t}) = \beta_{0k} + \beta_{[location[i]]k} + \beta_{[year[t]]k}$$

where each covariate corresponded to the change in abundance on the log scale.

The observation process model for individual detection probability was specified identically to the species-level detection model for the occurrence of use events. All prior specifications for covariates in both the state and process models were identical to the occupancy model.

Models were run in jags using R v. 4.1.2 with package jagsUI (Kellner 2015). Models were run for 30000 iterations with an adaptation of 1000 iterations, a burn-in of 1000 iterations, and a thinning rate of 10, across 6 chains, yielding a total of 17400 posterior samples. We visually inspected trace plots for model convergence and considered all parameters to have converged when Gelman-Rubén values were <1.10 . We examined model goodness of fit by comparing Freeman-Tukey residuals for the observed and model generated dataset. We calculated a Bayesian P-value for the model by summing the residuals across sites, years, and species, and determining the percentage of iterations where the residuals from the observed data exceeded the residuals of the predicted data. Values close to 0.5 indicate high explanatory power. We summarized all parameters using 90% Highest Density Intervals (HDI), and effects were considered strong if HDI intervals did not include zero.

Concept Designs for Elevated Road Segments on Primary Roadways

State Departments of Transportation and Counties have expressed interest in how the elevated road segment (ERS) concept constructed in the Sierra National Forest could be adapted to higher traffic volume roads. Therefore, this aspect of the project employed creative transportation engineers to come up with preliminary concept designs and guidance for these entities as a starting point to adapt this concept to primary roads and highways.

The scope of this work was to conduct a transportation engineering evaluation of design considerations for the elevated road wildlife crossing concept for use on primary roads and highways to meet county, city, state, and federal standards. The scope included developing at least two concept designs that meet the design criteria of extended open low-elevation passages along improved roads. It also includes design components for allowing these passages to be wetted during rain events when many migratory amphibians make large scale movements between breeding and upland habitats. Dokken Engineering conducted this work, regularly consulted with USGS, and also received input from Tom Langton (Herpetofauna Consultants International Ltd., Langton and Clevenger 2021) and Caltrans biologists and engineers. USGS provided further funding to support Dokken in producing professional quality photographic renderings of the concept designs.

Results

Fence Movement - Yosemite Toads

We documented a total of 42 individually identified Yosemite toads moving along the meadow facing fence line during the study period (27 in 2018; 10 in 2019, 4 in 2020, and only 1 in 2021). Three or fewer individuals (3 photo events) were not included in the initial analysis due to low confidence in these identifications. Of the 42 individuals in the analysis, 24 were subadults (<44 mm snout-to-vent length (SVL)) and 18 were adults (>44 mm SVL). Although there were 42 individual toads, 2 toads made movements along both mesh and solid fence lines, so their movements were split up in order to retain fence type in the analysis (n = 44). Among fence types, 12 subadult and 14 adult movements were recorded along the mesh and 12 subadult and 6 adult movements were recorded along the solid.

Of the 42 toads tracked using active trigger cameras, 9 successfully reached the cameras outside of the passage opening “success at reaching passage.” Of these, 5 were adults and 4 were subadults; 6 came from the solid fence side, while 3 came from the mesh fence side.

Movement distances of toads along the barrier fencing averaged approximately 46 m (median = 40, lower 90% tolerance interval = 20 m; Table 1, Figure 8A) and significantly differed by fence type, where mean distance moved was farther along the solid (61 m) than mesh (35 m) fencing (Table 1, Figure 8B). Although travel distances were not significantly different at the 90% confidence level by age class overall, adults travelled substantially longer distances along the solid fence (mean = 81 m) than the mesh fencing (mean = 51 m; Table 1, Figure 9A).

It is possible that differences in toad movements along fence types could be biased by differing locations where they encountered the fence or different directions of travel, particularly if these parameters were autocorrelated. However, distributions of initial toad encounter locations did not vary substantially by age class or fence type (Figure 9B). In addition, linear regression modeling showed no significant difference in distances moved by Yosemite toads in relation to the initial location where they encountered the fence or their initial direction of travel (Figure 10).

There were no significant differences at the 90% confidence level in the movement speed or number of detected direction changes by fence type (mesh vs. solid; Table 1). Movement speed was significantly different by age class, as adult Yosemite toads moved faster at an average of 1.1 m/min and subadults moved an average of 0.7 m/min. Toads were detected changing directions an average of 0.5 times per 20 m (i.e., per camera location). Direction changes were greater for adults and along solid fencing, but not significantly.

Eight out of 11 Yosemite toads changed course at a turnaround back toward the fence line or out into habitat, and of these, four toads were subsequently documented on other cameras 40–80 m away continuing to move back along the fence line.

Table 1. Yosemite Toad Movement Metrics by Fence Type and Age Class

		Sample Size	Fence Distance Moved (m)		Movement Speed (m/min)*		Direction Changes detected per 20m	
			Mean (se)	90% CI	Mean	90% CI	Mean	90% CI
By Fence Type	Solid	18 (15*)	61.0 (7.7)	48.3- 73.7	0.91 (0.12)	0.71- 1.10	0.61 (0.16)	0.36- 0.87
	Mesh	26 (11*)	34.7 (4.3)	27.6- 41.8	0.81 (0.15)	0.56- 1.06	0.42 (0.14)	0.19- 0.65
By Age Class	Subadult	24 (15*)	45.6 (5.5)	36.5- 54.7	0.68 (0.09)	0.53- 0.83	0.40 (0.12)	0.21- 0.60
	Adult	20 (11*)	45.3 (7.4)	33.2- 57.4	1.12 (0.15)	0.87- 1.37	0.61 (0.18)	0.32- 0.91
By Fence Type and Age Class	Solid-Subadult	12 (10*)	51.0 (8.3)	37.3- 64.7	0.77 (0.11)	0.59- 0.95	0.57 (0.19)	0.26- 0.87
	Solid-Adult	6 (5*)	81.0 (13.5)	58.9- 103.0	1.18 (0.24)	0.78- 1.58	0.71 (0.30)	0.21- 1.21
	Mesh-Subadult	12 (5*)	40.2 (7.4)	28.1- 52.3	0.50 (0.14)	0.27- 0.73	0.25 (0.14)	0.01- 0.48
	Mesh-Adult	14 (6*)	30.0 (4.8)	22.1- 37.9	1.07 (0.21)	0.73- 1.41	0.57 (0.23)	0.20- 0.95
All Toads		44 (26*)	45.5 (4.5)	38.1- 52.8	0.87 (0.09)	0.71- 1.02	0.50 (0.10)	0.33- 0.67

*individuals that passed more than one camera where movement speed was calculated

A) All Toads Movement Distribution

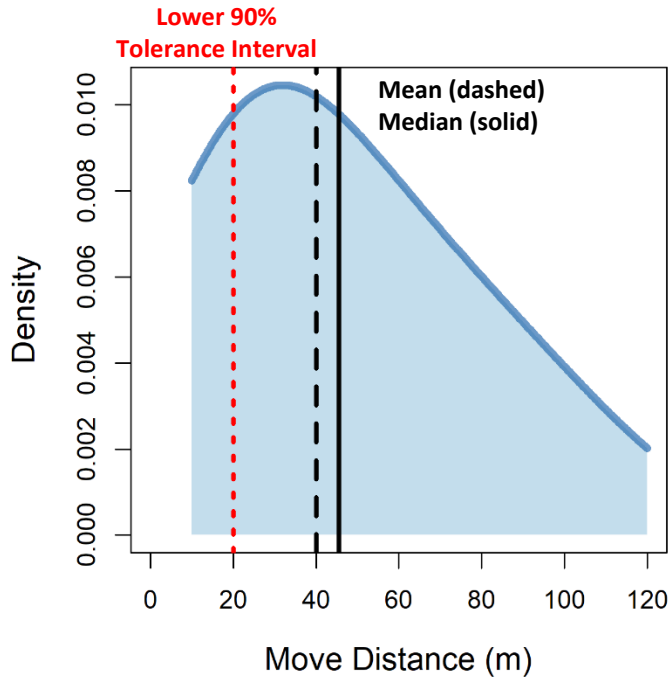

B) Distance by Fence Type

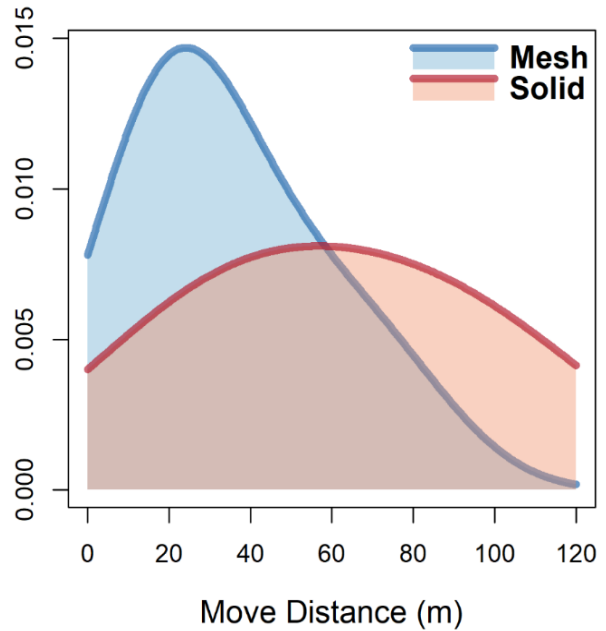
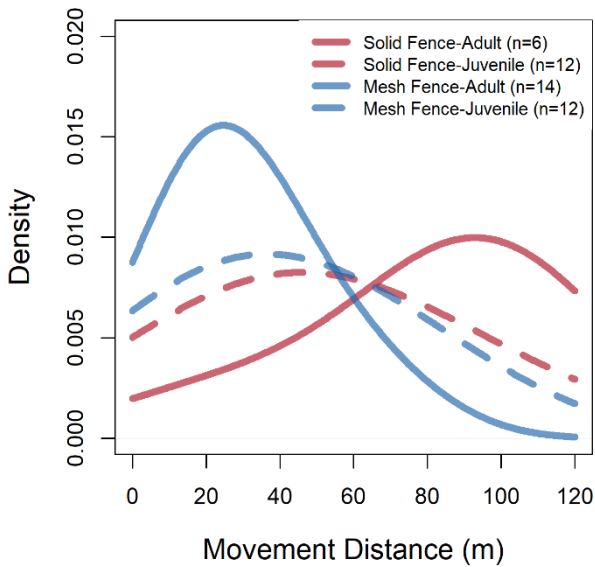

Figure 8. Distributions of Movement Distances A) Overall and B) by Fence Type. Lines Represent Mean (solid black), Median (dashed black), and lower 90% Tolerance Interval (red dotted).

A) Distance by Fence Type and Age



B) Initial Encounter Location by Fence Type and Age

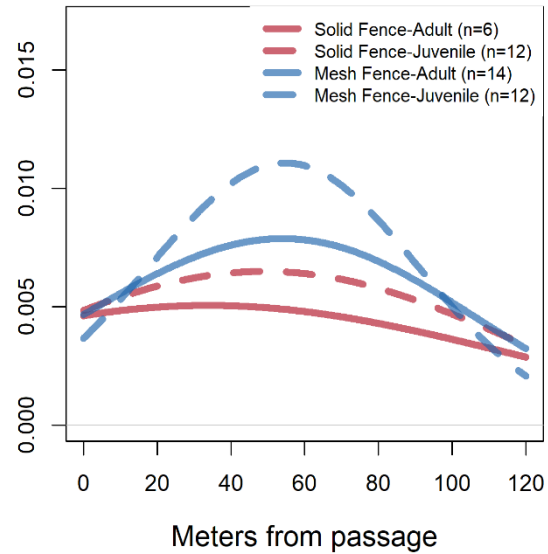
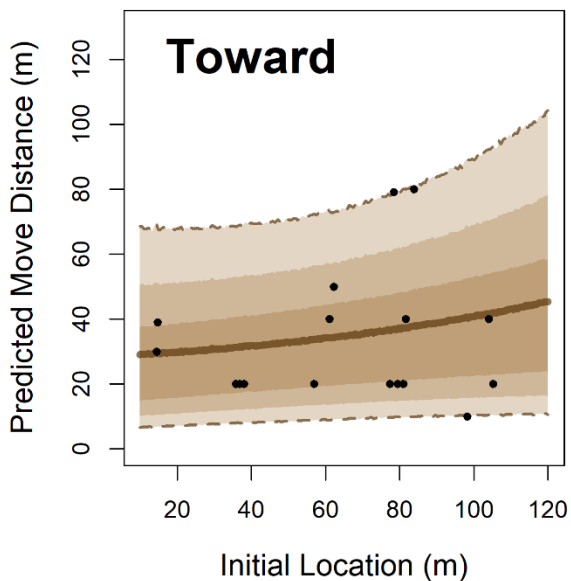

Figure 9. Yosemite Toad Movements by Fence Type and Age Class, A) Movement Distances and B) Distribution of Initial Encounter locations.

A) Distance by Initial Encounter Location (moving toward ERS)



B) Distance by Initial Encounter Location (moving away from ERS)

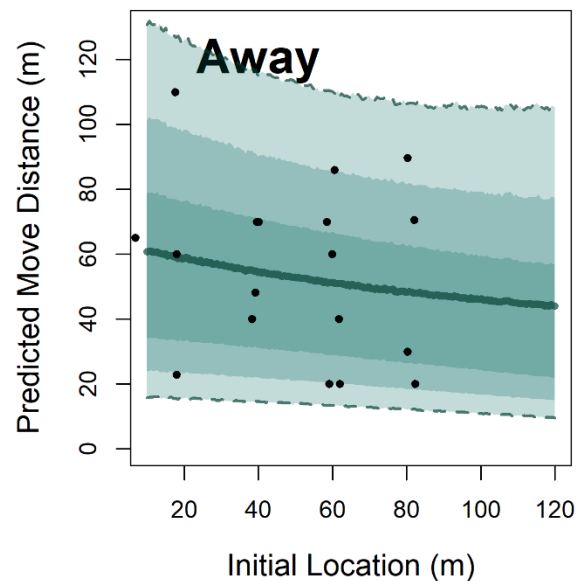

Figure 10. Movement Distance by Initial Location and Direction of Travel with 50%, 75%, and 90% Confidence Intervals (shading), A) Toads Initially moving Toward Passage and B) Toads Initially moving away from passage.

The probability that Yosemite toads reached the passage (0 m camera) decreased rapidly with increasing distance from the ERS system and was highly dependent upon their initial direction choice. Yosemite toads had a high probability of reaching the ERS passage if they encountered the fence at a distance of 20 m and were moving toward the ERS. Probabilities rapidly declined beyond those distances and were lower if the toads were first detected moving away from the ERS (Table 2, Figure 11A). Although adult Yosemite toads moved longer distances along solid fencing, there was no evidence that main effects of fence type or age class predicted the probability a Yosemite toad reached the passage in this study (Figure 11B). The estimates close to 1.0 and 0.0 and large confidence intervals indicate more data at a finer scale may more accurately predict the probabilities of success.

Table 2. Probability of Reaching Underpass by Initial Location, Direction of Travel (Toward or Away from Passage), and Fence Type.

Initial Direction of Travel	Initial Distance from ERS	Mesh			Solid			Both		
		Mean	Lower 90% CI	Upper 90% CI	Mean	Lower 90% CI	Upper 90% CI	Mean	Lower 90% CI	Upper 90% CI
Toward Passage	10	1.00	0.99	1.00	1.00	1.00	1.00	1.00	0.99	1.00
	20	0.93	0.54	1.00	0.98	0.88	1.00	0.95	0.71	1.00
	40	0.02	0.00	0.14	0.11	0.00	0.70	0.07	0.00	0.42
	60	0.00	0.00	0.00	0.00	0.00	0.00	0.00	0.00	0.00
	80	0.00	0.00	0.00	0.00	0.00	0.00	0.00	0.00	0.00
	100	0.00	0.00	0.00	0.00	0.00	0.00	0.00	0.00	0.00
Away from Passage	10	0.17	0.01	0.48	0.52	0.25	0.79	0.35	0.13	0.63
	20	0.13	0.01	0.37	0.44	0.20	0.71	0.29	0.11	0.54
	40	0.08	0.00	0.23	0.31	0.10	0.56	0.19	0.05	0.40
	60	0.05	0.00	0.16	0.21	0.03	0.48	0.13	0.02	0.32
	80	0.03	0.00	0.13	0.15	0.01	0.44	0.09	0.00	0.28
	100	0.02	0.00	0.11	0.11	0.00	0.42	0.07	0.00	0.26

A) Success Probability by Fence Type and Initial Direction Choice

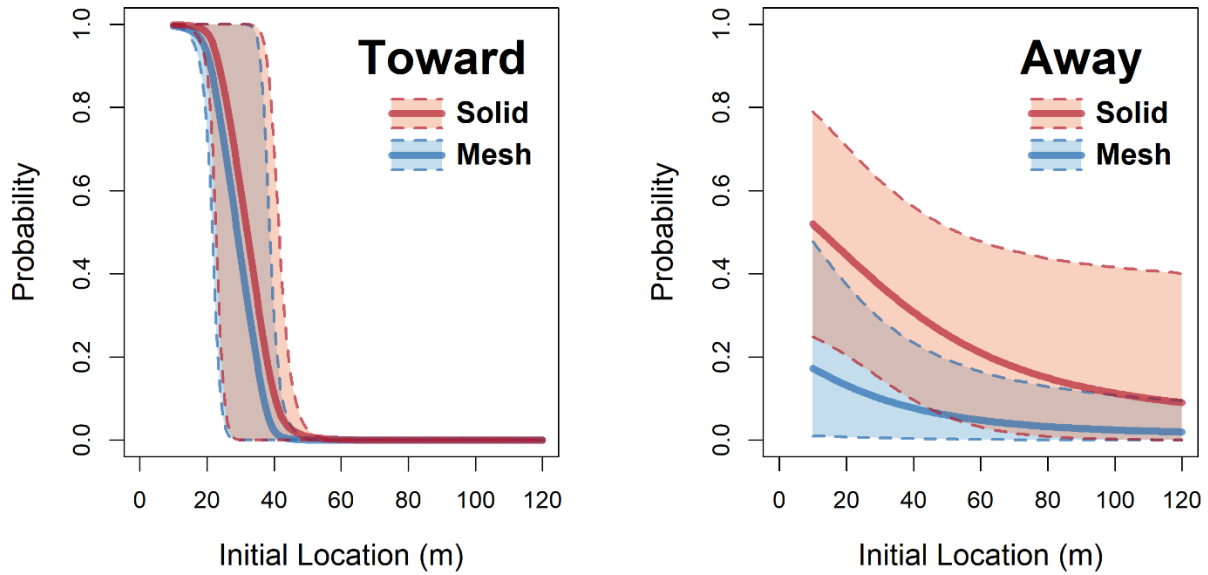

B) Success Probability by Age Class and Initial Direction Choice

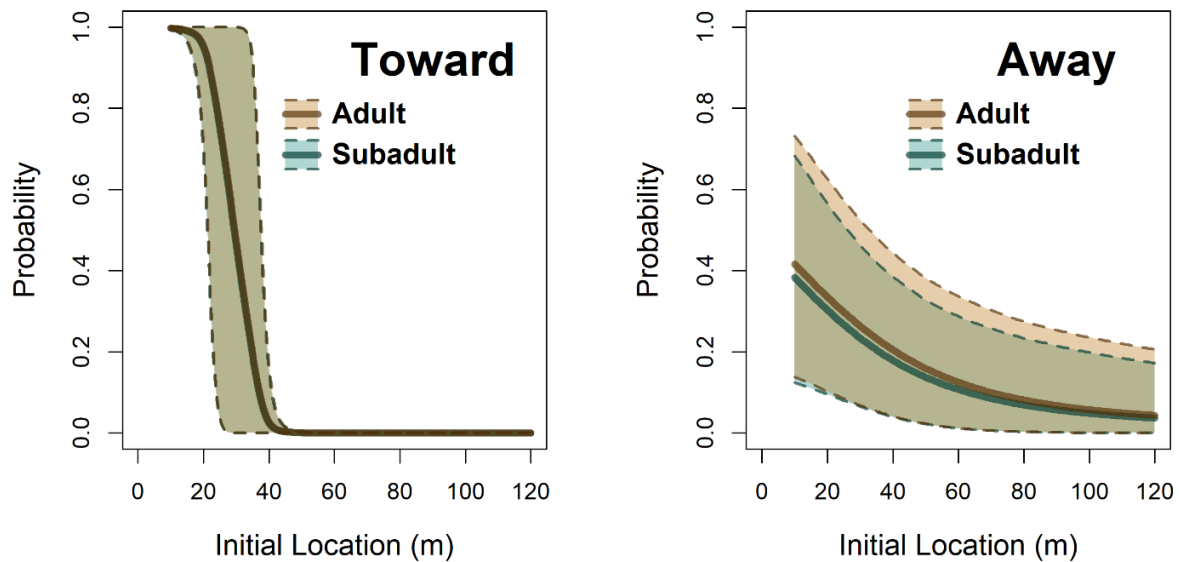

Figure 11. Probability of Reaching Underpass by Initial Location and Direction of Travel (Toward or Away from Passage) with 90% Confidence Intervals: A) by Fence Type (solid vs. mesh) and B) by Age Class (adult vs. subadult).

ERS Passage Permeability- Yosemite Toads

The relative activity of Yosemite toads immediately inside vs. outside (~5 m from opening) of the ERS crossing system was almost equal (21 vs. 19 events: 1 min interval). Of the eight individually identified Yosemite toads that were tracked moving along the fence toward the ERS system at one of the “0 m” cameras (~8 m from the ERS entrance), three moved underneath at the first immediate right/left turn from the barrier fencing into the ERS and two moved along the length of the ERS (not underneath) to the barrier fencing on the other side. It is possible the other three toads moved under the ERS but not across a HALT trigger. Toads were detected on the time lapse cameras during the periods of activity but could not be identified to individual.

Twenty-nine other Yosemite toads were documented moving under the ERS. These were detected by one of the two HALT triggers (20 toads) or by a time lapse camera within the ERS (9 toads). These data represent only a subsample of available linear width of the ERS passage system, so we suspect more Yosemite toads passed under the crossing. At an average movement speed of 1 m/min and a field of depth of about 1 m, we estimate the eight time-lapse cameras subsampled toads across approximately 40% of the linear length of the ERS for 20% of the time. Because of this, we expect the total number of toads that moved under the ERS was greater than 100 during the time periods monitored.

ERS Passage Permeability- All Small Animal Species

We observed 19,079 species use events, across 4 years of camera sampling. Of these, 9,881 use events were considered unique, given our 30-minute independence criteria. These included 7,753 observations of mammals, 1,501 observations of amphibians, and 627 observations of reptiles, across 22 species (Table 3). The most common species included white-footed mice (*Peromyscus* spp., $n = 5783$) and Pacific tree frogs (*Pseudacris regilla*, $n = 1175$). Lower numbers of animals in general were documented in 2019, likely due to the shorter monitoring period that year from a late snow melt and other factors.

Species-level detection probability for the occurrence of use averaged 0.17 (90% CL: 0–0.45) for the entire community. Detection probability increased as camera activity time during each sampling period increased, corresponding to a 4.0 (90% CL: 2.17–7.17) times higher probability of detection when cameras were active for 10 more sampling days. Detection was also 3.8 times greater (90% CL: 2.70–5.33) in cameras situated directly on the fence, compared to those cameras placed within the underpass but not along the fence. Species-level detection was not associated with season. Similarly, species-level detection probability for the abundance model averaged 0.17 (0.04–0.27) for the entire community. Camera activity time again had a strong positive effect, resulting in 1.7 (1.07–2.67) times greater individual detection probability for every 10-day increase in activity time. There was not a detectable effect of camera position or season on individual detection probability at the community-level. Detection model coefficients are presented in Appendix 1.

Table 3. Total Numbers of Photos from all Cameras by Species and Year (after removal of repeat detections within 30 min time window used for analysis)

		Year				
		2018	2019	2020	2021	Sum
Amphibians	Pacific tree frog <i>Pseudacris regilla</i>	755	173	73	174	1175
	Sierra Nevada Ensatina <i>Ensatina eschscholtzii platensis</i>	116	27	2	9	154
	Yosemite toad <i>Anaxyrus canorus</i>	90	68	8	6	172
Mammals	American marten <i>Martes americana</i>	0	12	0	8	20
	Broad-footed Mole <i>Scapanus latimanus</i>	0	0	1	0	1
	Bushy-tailed Woodrat <i>Neotoma cinerea</i>	0	0	19	54	73
	California Ground Squirrel <i>Otospermophilus beecheyi</i>	1	0	1	15	17
	Chipmunk <i>Neotamias speciosus</i>	78	14	136	240	468
	Douglas Squirrel <i>Tamiasciurus douglasii</i>	152	104	92	151	499
	Golden-mantled Ground Squirrel <i>Callospermophilus lateralis</i>	3	0	6	24	33
	Long-tailed Weasel <i>Mustela frenata</i>	5	0	9	5	19
	Mountain Pocket Gopher <i>Thomomys monticola</i>	13	5	25	31	74
	Northern Flying Squirrel <i>Glaucomys sabrinus</i>	0	4	1	6	11
	White-footed mice species <i>Peromyscus spp.</i>	1804	731	1484	1764	5783
	Shrew <i>Sorex spp.</i>	123	82	122	75	402
	Spotted skunk <i>Spilogale gracilis</i>	2	2	0	0	4
	Vole <i>Microtus spp.</i>	134	23	98	61	316
Yellow-bellied Marmot <i>Marmota flaviventris</i>	19	4	10	0	33	
Reptiles	Mountain Gartersnake <i>Thamnophis elegans elegans</i>	97	80	19	26	222
	Rubber Boa <i>Charina bottae</i>	53	36	40	16	145
	Sierra Alligator Lizard <i>Elgaria coerulea</i>	58	33	49	40	180
	Western Fence Lizard <i>Sceloporus occidentalis</i>	11	14	13	42	80

Probability of Use (Occupancy by Season)

Results for all species compare the probabilities of occupancy at three general locations: 1) under the ERS passage, 2) immediately outside the ERS passage (within 0–18 m of passage and approximately <5 m from road), and 3) in the forest (>18 m from passage and approximately >5 m from road). The area immediately outside the ERS and adjacent to the road was generally more open and lacked the leaf litter and shrub/forest canopy that was present farther away from the road in the forest. The probability that a species was present in seasons and years did not vary by location within species or at the community level (Appendix 1).

Relative Activity / Use (Relative Abundance by Season)

Over all species and accounting for temporal variation, relative activity was lower in the open area adjacent to the road/ERS in comparison under the ERS or in the forest. Model coefficients are presented in Figure 2 and Appendix 2. Due to high variations in temporal and spatial activity within and among species, confidence intervals were relatively large. However, within species, location was not significantly different across locations at both 75% and 90% confidence levels (Table 4, Figure 12). However, there were notable trends in activity estimates within and among species.

Model estimates of mean predicted amphibian activity were highest in the forest and lower under the ERS. This was most apparent for non-migratory Pacific tree frogs and ensatina salamanders (*Ensatina eschscholtzii platensis*; Table 4, Figure 12). Mean predicted activity was similar in the habitat adjacent to the ERS and under the ERS for Sierra Nevada ensatina salamanders and Yosemite toads. This general trend was also documented for snakes (rubber boa (*Charina bottae*) and mountain gartersnake (*Thamnophis elegans elegans*)), but not lizards (Sierra alligator lizard (*Elgaria coerulea*), western fence lizard (*Sceloporus occidentalis*) which had roughly equal activity in the forest and under the ERS.

In contrast, small mammal species tended to have higher activity under the ERS in comparison to the adjacent habitat and forest. This trend was most notable for bushy-tailed woodrats (*Neotoma cinerea*), Lodgepole chipmunks (*Neotamias speciosus*), and most squirrel species (Table 4, Figure 12).

Table 4. Effect of location on the relative activity of amphibians, small mammals, and reptiles. Mean estimates and 90% confidence intervals are presented for 3 locations: 1) within the underpass (Under ERS), 2) immediately adjacent to the underpass and roadway (Adjacent to ERS), and 3) in the forest (Outside ERS).

		Under ERS		Adjacent to ERS		Outside ERS	
		mean	90% CI	mean	90% CI	mean	90% CI
Amphibians	Pacific tree frog <i>Pseudacris regilla</i>	15.2	2.8- 26.1	40.5	6.9- 58.3	56.8	11.8- 94.9
	Sierra Nevada Ensatina <i>Ensatina eschscholtzii platensis</i>	2.2	0- 5.3	4.4	0.1- 11.6	14.5	0.9- 37.3
	Yosemite toad <i>Anaxyrus canorus</i>	2.0	0- 4.7	2.8	0.1- 6.3	5.4	0.1- 5.7
Mammals	American marten <i>Martes americana</i>	0.8	0- 1.7	0.3	0- 0.6	0.5	0- 1.2
	Broad-footed Mole <i>Scapanus latimanus</i>	0.1	0- 0.2	0.1	0- 0.1	0.0	0- 0.1
	Bushy-tailed Woodrat <i>Neotoma cinerea</i>	3.7	0- 8.3	1.0	0- 2.2	0.2	0- 0.4
	California Ground Squirrel <i>Otospermophilus beecheyi</i>	0.9	0- 2.1	0.5	0- 1.1	0.1	0- 0.4
	Chipmunk <i>Neotamias speciosus</i>	18.3	0.8- 8.7	9.8	0.5- 19.4	5.2	0.2- 2.7
	Douglas Squirrel <i>Tamiasciurus douglasii</i>	37.1	15.6- 61.7	12.8	4- 23	25.2	9.8- 42
	Golden-mantled Ground Squirrel <i>Callospermophilus lateralis</i>	1.8	0- 3.8	1.1	0- 2.4	0.3	0- 0.8
	Long-tailed Weasel <i>Mustela frenata</i>	0.5	0- 1.1	0.4	0- 0.9	0.6	0- 1.3
	Mountain Pocket Gopher <i>Thomomys monticola</i>	0.8	0.1- 1.4	0.7	0- 1.4	1.5	0.2- 2.6
	Northern Flying Squirrel <i>Glaucomys sabrinus</i>	0.2	0- 0.5	0.1	0- 0.3	0.7	0- 1.4
	White-footed mice species <i>Peromyscus spp.</i>	144.7	65.1- 188.1	104.1	31.5- 97.3	195.3	50.3- 142.3
	Shrew <i>Sorex spp.</i>	51.3	6.6- 108.5	27.2	2.3- 59.4	47.0	6.9- 103.3
	Spotted skunk <i>Spilogale gracilis</i>	0.3	0- 0.6	0.1	0- 0.3	0.1	0- 0.2
	Vole <i>Microtus spp.</i>	3.0	0.5- 5.7	3.4	0.6- 6.8	5.9	0.9- 6
	Yellow-bellied Marmot <i>Marmota flaviventris</i>	1.1	0- 2.4	0.6	0- 1.5	0.7	0- 1.5
Reptiles	Mountain Gartersnake <i>Thamnophis elegans elegans</i>	3.2	0.6- 6.4	5.1	0.8- 9.9	7.9	1.8- 14.7
	Rubber Boa <i>Charina bottae</i>	1.5	0.2- 2.5	3.1	0.5- 5.5	4.2	0.8- 6.8
	Sierra Alligator Lizard <i>Elgaria coerulea</i>	7.3	2.6- 12.3	2.6	0.5- 4.7	5.4	1.7- 8.9
	Western Fence Lizard <i>Sceloporus occidentalis</i>	1.0	0.2- 1.9	1.8	0.3- 3.3	1.8	0.5- 3.2

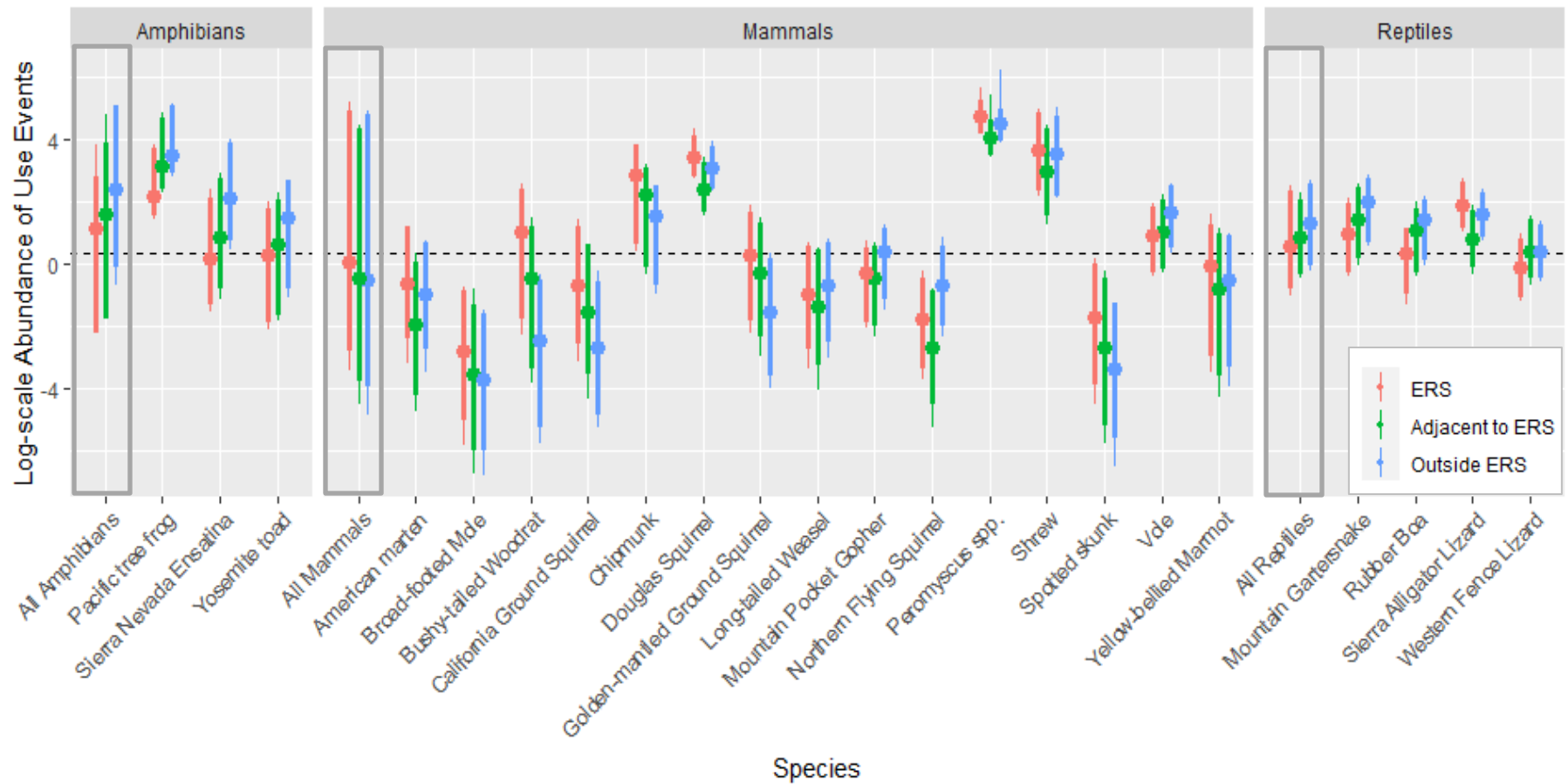

Figure 12. Effect of location on the relative activity of amphibians, small mammals, and reptiles. Mean estimates and 90% confidence intervals are presented for 3 locations: 1) within the underpass (Under ERS-red), 2) immediately adjacent to the underpass and roadway (Adjacent to ERS-green), and 3) in the forest (Outside ERS-blue). Mean estimates are presented as filled circles, 75% confidence intervals as thicker lines and 90% confidence intervals as thin lines. The dotted horizontal line is mean activity for all species at all locations (log scale).

Concept Designs for Elevated Road Segments on Primary Roadways

Dokken Engineering produced four ERS concept designs with renderings and an engineering evaluation for use in planning similar structures on primary roads and highways (Appendix 2). The report includes discussions of design considerations, materials and relative cost considerations.

Discussion

Research to Inform Passage Spacing for Migratory Amphibians: Yosemite Toad

Although the sample size was low due to severe drought conditions in the last two years of the study and sampling constraints, we found similarities between the fence movement behavior of Yosemite toads and other migratory amphibians. On average, Yosemite toads moved a distance of 46 m along barrier fencing before “giving up” and their probability of making it to the crossing decreased rapidly with increasing distance from the ERS. This is close to the ~40 m average give-up distance that Ottberg and van der Grift (2019) reported for common toads that did not find a passage in the Netherlands and the 40 m average we documented for the California tiger salamander in Stanford, CA (Brehme et al. 2021). Many individuals moved back and forth along the fencing. Approximately 90% of toads were estimated to move 20 m or more along the fence, with an average distance of 46 m. Because our cameras were set 20 m apart, we were unable to estimate more specific distances with high confidence. However, these preliminary results suggest that passages spaced within 20 m of one another along Yosemite toad migratory pathways are likely to provide connectivity to 90% of the population.

In addition to distance moved, the direction Yosemite toads turned when reaching the barrier fencing had a large influence on whether they reached the crossing. Toads that reached the barrier fencing and then travelled in the wrong direction (away from the passage) were significantly less likely to reach the passage than toads that made the correct initial direction choice. This was also documented in the only two similar fence movement studies of the common toad and CTS (Ottberg and van der Grift 2019, Brehme et al. 2021)

It is possible that not all Yosemite toads were making migratory movements during our study, as they may have been foraging. However, in that case we would expect to document the same individuals on multiple dates along the fence line which was rare in our study.

The average distances moved by Yosemite toads were significantly greater along solid vs. mesh fencing (1.8 times). These differences were particularly marked for adult toads, whose movement distances averaged 2.7 times greater along the solid fence. Fence type did not significantly predict whether toads reached the underpass system, although estimates were higher along solid fencing, particularly for toads that initially moved away from the passage. There were no significant differences in speed or turnaround rates (moving back and forth) by fence type.

We continue to suggest solid fencing may be more effective if fencing is used for the purpose of leading migrating amphibians and other small animal species to a passage. Other studies have shown that animals interact with transparent fencing with behaviors such as poking, attempting to climb, and moving back and forth (Ruby et al. 1994, Milburn-Rodríguez et al. 2016, Brehme and Fisher 2020, Brehme et al. 2021). The higher energy and time expenditures of these behaviors may have negative impacts on breeding success (Carr 2011, Navas et al. 2016). However, mesh fencing has benefits in ease of installation, increased permeability to wind and water, and reduced temperature and wind differentials from the surrounding environment (Boyle et al. 2019, Langton and Clevenger 2021). In concurrent studies on lizards, snakes and toads, we have found that addition of a 15 cm (6 in.) solid visual barrier along the bottom edge of the fence can reduce these fence interaction behaviors and increase the speed of movement to that comparable to a full solid barrier (Brehme and Fisher 2020). The potential use of visual barriers could allow flexibility in choosing fence materials for amphibian crossing systems. We are currently testing this as part of a Before-After Control-Impact (BACI) study for California tiger salamanders in Stanford, CA. It is important to note that effectiveness of fence materials and designs can vary based on taxon, species, body size and climbing ability (e.g., Woltz et al. 2008, Huijser and Gunson 2019, Langton and Clevenger 2021, Macpherson et al. 2021).

In relation to longevity and maintenance, we have found that different fence types may be more suitable for some habitats than others. For instance, for stand alone fencing (vs. those attached to existing fence), plastic (i.e., Animex®) was more resilient to high snowfall in the winters, whereas mesh fencing (e.g., Ertec® polymer matrix, hardware cloth) was more likely to get flattened between attachment posts from the weight of snow. Alternatively, mesh fencing was more resilient to high winds of desert environments as well areas where substantial water permeability was needed. Use of steel t-posts was best for heavy snow and looser soils (vs. plastic posts or rebar). In our studies, annual maintenance of both types of these temporary/semi-permanent fences was also required. This included straightening fencing, adding posts to less stable areas, and replacement of approximately 20% of the fasteners (fence to post: freeze and solar resistant plastic zip ties and steel zip ties). More permanent solutions include the use of concrete and steel fencing or attaching these types of barriers to existing permanent fencing.

Barrier fencing is an important component of road crossing systems to effectively lead animals to road crossings (e.g., van der Ree et al. 2015). However, without considering animal movements along fencing in planning for distances between crossings, there is a potential for crossing systems to become a barrier to movements necessary for persistence. This is particularly relevant when high connectivity is important for the sustainability of the population, such as for migratory amphibian species that must make movements necessary for population persistence between upland and breeding habitats. With non-migratory species, less frequent cross-road movements could be acceptable if roads do not transect seasonal habitats or vital resources. In these cases, occasional crossings to enable reproductive and genetic connectivity may be sufficient to maintain long term population persistence (e.g., Mills and Allendorf 1996, Crosgrove et al. 2018).

Elevated Road Segment Permeability

Initial results showed that the ERS crossing has a high potential to provide increased connectivity for Yosemite toads and a wide range of other amphibian, reptile, and small mammal species while greatly reducing road mortality. No road mortality of Yosemite toads has been documented in the project footprint since installation of the ERS (C. Vaughan, S. Barnes, USFS, pers. comm). This new prototype crossing can be made to any length, creating a wide passage without constricting migratory movements to small tunnels. The prototype ERS also allows natural light, moisture and rainfall to permeate the length of the passage so that climate and moisture underneath is similar to that outside. The passage did present challenges in monitoring successful crossings due to the wide monitoring area. We are exploring solutions to better monitor movements near and underneath such wide passages in the future.

All small animals species that were detected in the forest habitat were also detected under the ERS structure, with the exception of the broad-footed mole (*Scapanus latimanus*, n = 1) and northern flying-squirrel (*Glaucomys sabrinus*, n = 11). There were no significant differences in activity of amphibian, reptile and small mammal species among camera sites under the ERS and in the surrounding forest habitat. However, amphibian activity generally trended lower under the ERS than in the forest habitat, while small mammals trended higher underneath the ERS structure.

The ERS structure in the Sierra National Forest was set on top of a solid impervious aggregate roadbed. Although activity did not differ significantly under the ERS in relation to adjacent habitat, we postulate that slightly lower general trends in amphibian activity may be associated with lack of natural soil under the ERS and lack of leaf litter and cover in the road edge habitat. Amphibians other than Yosemite toads (e.g., Pacific tree frogs, *Ensatina* salamanders) were likely foraging within their home ranges, rather than migrating, and the natural habitats outside of the open road and verge better support these activities. Potential increased use of the ERS by some small mammals may be due to the ERS offering cover from aerial predators, as well as providing shade during daytime hours. Although competitive and other interactions may occur among taxa, no such interactions were recorded during our camera monitoring and small mammals are not widely known to prey upon reptiles and amphibians.

That said, the permeability of the ERS to individual Yosemite toads was high and the level of activity of all species under the ERS was high, particularly considering that many species are not migratory and likely have small home ranges that do not overlap the roadway. This indicates that the structure is highly effective in maintaining connectivity for a wide variety of small animals while protecting them from mortality from vehicular collisions. The extended 30 m (100 ft.) width and openness of the ERS prototype, as well as its permeability to rainfall and natural light offers a much wider and more natural safe passage for movement of small animals across the road than standard culverts and microtunnels. This is particularly important for species that make regular migratory movements among habitats for breeding and other resources. Planting of shrubs and

maintenance of vegetation up to the opening adjacent to the structure may enhance passage for species that avoid open areas (e.g., Goosem 2001).

Concept Designs for Elevated Road Segments on Primary Roadways

Although they may have a higher initial cost, there are advantages in building elevated road structures in comparison to below grade crossings, including smaller area of impact, less susceptibility to flooding, and greater suitability in areas with challenging topography (flat lands, hilly and extreme terrains). The designs also eliminate or reduce the need for barrier fencing and can theoretically be built to any length depending upon the needs of the species. The ERS system installed in the Sierra National Forest was built to meet USFS, City and County road specifications and can be removed and re-installed as desired. This ERS has been in operation since 2018 with frequent use of off-road vehicles, large recreational vehicles, logging trucks, and fire trucks. Semi-annual to annual checks and maintenance have been required to ensure all bolts and connectors are tight. Replacement of wood mats or portions thereof may be required in the future. However, with ongoing regular maintenance, these may be permanent structures (Jon Fiutak, Anthony Composites, pers. comm). Similar structures fabricated with a steel grated surfaces could also be considered.

For high use primary roads and highways, this level of maintenance may not be desired. Therefore, concept ERS designs generated for these high use roads range from low bridge designs to less costly repeating adjacent passage designs along a raised roadbed. These were all designed so that target species can move along a relatively natural terrain path and cross the roadway with a natural soil bottom similar to the surrounding habitat. Depending upon the specific area, water conveyance structures may be incorporated into or separate from passages to allow for small amounts of water flow through the passages. All passages have a suggested height of at least 1 foot and wide openings to better ensure high permeability to animal movement. They also all contain sections of grated openings to allow natural light and moisture to reach the passage surface during rainfall events when amphibians typically migrate. Although noise from vehicles is not alleviated with these concepts and deserves consideration, the open designs reduce any temperature or moisture differential between the passage and outside environment.

For repeating passage designs, the distance between passages may be informed by fence movement distances of target or similar species, such as those previously demonstrated with California tiger salamanders (Brehme and Fisher 2020, Brehme et al. 2021) and with Yosemite toads in this report. All plans also include smooth solid side walls and overhangs to prevent climbing and keep small animals off of the roadway (where appropriate depending upon design and target species), while barriers for traffic are included to meet all safety standards for vehicles, bicyclists, and pedestrians.

The concept designs, engineering evaluation and guidance document for primary roads and highways provide a starting point for local and DOT engineers to design and build permanent

structure(s) to enhance the movement of small wildlife, particularly for, but not limited to, migrating amphibians over wide stretches of roadway (Appendix 2).

Considerations for Future Studies

To further inform the design of effective barrier and passage systems for migrating amphibians and small animal species, we suggest consideration of the following research:

1. Include one or more new study locations and species to better predict underpass spacing needs for high-risk migratory amphibian species. This would address the question of whether movement distances along barrier fencing are predictable among species groups and size classes.
2. Assess permeability of existing or newly built passages, particularly those incorporating new design elements, to amphibian (and other target species) movements. Concurrent population abundance monitoring would help to inform the responses of populations to increased or decreased connectivity.
3. Study the effects of traffic noise on migratory movements of amphibians (and other target species).
4. Continue research to assess the effectiveness of fence end treatments by studying the effect of turnaround length, materials and configuration on species turnaround rates at fence ends. We have found that turnarounds are highly effective in changing the movement trajectory of reptiles and amphibians (Brehme and Fisher 2020).
5. Work with engineers to design (and test if possible) new options to add to existing best management practice elements for increasing effectiveness of road crossings for herpetofauna such as:
 - a. Artificial lighting in tunnels to simulate natural lighting for diurnal species. This is mainly for long underpasses where grated skylights in the shoulders and median are not feasible or sufficient to illuminate a passage.
 - b. Drip or other drainage systems that deposit a path of moisture in otherwise dry underpasses during rain events.
 - c. Other design modifications to decrease the temperature differential between tunnel interiors and the surrounding environment.
 - d. Design modifications to incorporate cover and ledges for movement of small animal species within larger passages.

These types of studies could further inform transportation and conservation agencies so that they can better evaluate the effectiveness of existing barrier and road crossing systems, increase the ‘toolbox’ of innovative solutions, make more informed decisions on underpass spacing for high-

risk migratory species, and increase the effectiveness of crossing systems for migrating amphibians and other small animal species.

Acknowledgements

We thank the Nevada Department of Transportation, Transportation Pooled Fund Program Project for funding this multi-faceted project in 2022 (P342-20-803). We thank the U.S. Forest Service (USFS) for funding the ERS and for conducting maintenance and camera monitoring in all years of the study. Sterling Walker, Jim Weber, and Jon Fiutak from Anthony Hardwood Composites/EMTEK worked with the authors to design the ERS and turn our vision into reality. ERTEC generously donated water- permeable polymer matrix fencing and materials. We thank USFS for assisting in the installation and maintenance of the fencing. It was a group effort including several of the authors and Denise Clark, Tristan Edgarian, Jennifer Kingston, Devin Adsit-Morris, and Chase Stafford (USGS); Wesley Burton, Tony Borelli, Alonso Ruiz, Mindy McClurg, and Phil Mazon (USFS); Ed Schiedel (Volunteer USFS). We greatly appreciate the work of Dokken Engineering for the ERS design concepts and guidance to include John Klemunes; and associated input and comments from Tom Langton (Herpetofauna Consultants International Ltd), Carl Savage, Lindsay Vivian, Luz Quinzel, Robert Young, Robert Blizzard, Sophie Golding, Arnica McCarthy, Blake Hirara, (Caltrans). Finally, we thank USGS Western Ecological Research Center, USFWS, and Hobbs Ecology for funding and support in 2020, and the California Department of Transportation, Division of Research, Innovation and System Information (DRISI; Agreement 65A0553) for helping to fund the initial stages of the project in 2018–2019.

Literature Cited

- Allaback, M.L., and D.M. Laabs. 2002. Effectiveness of road tunnels for the Santa Cruz long-toed salamander. *Transactions of the Western Section of the Wildlife Society* 38: 5–8.
- Andrews, K.M., P. Nanjappa, and S.P. Riley (eds), 2015a. Roads and ecological infrastructure: concepts and applications for small animals. JHU Press, Baltimore, MD.
- Andrews, K.M., T.A. Langen, and R.P.J.H. Struijk. 2015b. Reptiles: Overlooked but often at risk from roads. *Handbook of Road Ecology*. Wiley, New York, pp. 271–280.
- Boyle, S.P., R. Dillon, J.D. Litzgus, and D. Lesbarrères. 2019. Desiccation of herpetofauna on roadway exclusion fencing. *Can Field Nat.* 133(1), 43–48.
- Brehme, C.S., S.A. Hathaway, and R.N. Fisher. 2018. An objective road risk assessment method for multiple species: ranking 166 reptiles and amphibians in California. *Landscape Ecology* 33(6): 911–935.
- Brehme, C.S., and R.N. Fisher. 2020. Research to Inform Caltrans Best Management Practices for Reptile and Amphibian Road Crossings. USGS Cooperator Report to California Department of Transportation, Division of Research, Innovation and System Information, 65A0553. <https://dot.ca.gov/-/media/dot-media/programs/environmental-analysis/documents/final-caltrans-usgs-report-herproadresearch-rev.pdf>
- Brehme, C.S., J.A. Tracey, B.A. Ewing, M.T. Hobbs, A.E. Launer, T.A. Matsuda, E.M.C. Adelsheim, and R.N. Fisher. 2021. Responses of migratory amphibians to barrier fencing inform the spacing of road underpasses: a case study with California tiger salamanders (*Ambystoma californiense*) in Stanford, CA, USA. *Global Ecology and Conservation*, 31, p.e01857.
- Brown, C., K. Kiehl, and L. Wilkinson. 2012. Advantages of long-term, multi-scale monitoring: assessing the current status of the Yosemite Toad (*Anaxyrus canorus*) in the Sierra Nevada, California, USA. *Herpetological Conservation and Biology*, 7(2), pp.115–131.
- Carr, J.A. 2011. Stress and reproduction in amphibians, in: Norris, D., Lopez, K.H., (Eds.), *Hormones and Reproduction of Vertebrates*. Academic Press. p. 99–116.
- Cosgrove, A.J., McWhorter, T.J. and Maron, M. 2018. Consequences of impediments to animal movements at different scales: a conceptual framework and review. *Diversity and Distributions*, 24(4): 448–459.
- Davidson, C., and G.M. Fellers. 2005. *Bufo canorus*. In: Lannoo M (ed) *Amphibian declines: the conservation status of United States species*. University of California Press, Berkeley, pp. 430–432.
- Denwood, M.J. 2016. “runjags: An R Package Providing Interface Utilities, Model Templates, Parallel Computing Methods and Additional Distributions for MCMC Models in JAGS.” *Journal of Statistical Software*, 71(9), 1–25. doi: 10.18637/jss.v071.i09.
- Drost, C.A., and G.M. Fellers. 1996. Collapse of a regional frog fauna in the Yosemite area of the California Sierra Nevada, USA. *Conservation Biology* 10: 414–425.
- Eigenbrod, F., S.J. Hecnar, and L. Fahrig. 2008. The relative effects of road traffic and forest cover on anuran populations. *Biological Conservation* 141(1): 35–46.

- Forman, R.T., D. Sperling, J.A. Bissonette, A.P. Clevenger, C.D. Cutshall, V.H. Dale, L. Fahrig, R. France, C.R. Goldman, K. Heanue, and J.A. Jones. 2003. Road ecology. Science and Solutions. Island Press, Washington.
- Gilbert, N.A., J.D. Clare, J.L. Stenglein, and B. Zuckerberg. 2021. Abundance estimation of unmarked animals based on camera-trap data. *Conservation Biology* 35(1), 88–100.
- Glista, D.J., T.L. DeVault, and J.A. DeWoody. 2008. Vertebrate road mortality predominantly impacts amphibians. *Herpetological Conservation and Biology* 3(1): 77–87.
- Goosem, M. 2001. Effects of tropical rainforest roads on small mammals: inhibition of crossing movements. *Wildlife Research*, 28(4), pp.351–364.
- Gould, P.R., M.R. Gade, A.J. Wilk, and W.E. Peterman. (in review, *Journal of Wildlife Management*). Short-term responses and Recovery of Riparian Salamanders to Wildfire in the Southern Appalachians.
- Hamer, A.J., and M.J. McDonnell. 2008. Amphibian ecology and conservation in the urbanising world: a review. *Biological Conservation* 141(10): 2432–2449.
- Hammerson, G, R. Grasso, and C. Davidson. 2004. *Anaxyrus canorus*. The IUCN Red List of Threatened Species 2004: e.T3180A9659674. <https://dx.doi.org/10.2305/IUCN.UK.2004.RLTS.T3180A9659674.en>. Downloaded on 28 May 2020.
- Hobbs, M.T., and C.S. Brehme. 2017. An improved camera trap for amphibians, reptiles, small mammals, and large invertebrates. *PLOS ONE* 12(10), p.e0185026.
- Huijser, M.P., and K.E. Gunson. 2019. Road Passages and Barriers for Small Terrestrial Wildlife: Summary and Repository of Design Examples NCHRP 25-25. Research for the AASHTO Committee on Environment and Sustainability. <https://apps.trb.org/cmsfeed/TRBNetProjectDisplay.asp?ProjectID=4337>
- Jennings, M.R., and M.P. Hayes. 1994. Amphibian and reptile species of special concern in California (p. 255). Rancho Cordova, CA: California Department of Fish and Game, Inland Fisheries Division.
- Kellner, K. 2015. jagsUI: a wrapper around rjags to streamline JAGS analyses. R package version, 1(1).
- Kery, M., R.M. Dorazio, L. Soldaat, A. Van Strien, A. Zuiderwijk, and J.A. Royle. 2009. Trend estimation in populations with imperfect detection. *Journal of Applied Ecology*, 46(6), 1163–1172.
- Langton, T.E.S. Ed. 1989 Amphibians and Roads. Proceedings of the Toad Tunnel Conference Rendsburg, Federal Republic of Germany, 7-8 January 1989. ACO Polymer Products Ltd., Shefford.
- Langton, T.E.S., and A.P. Clevenger. 2017. Amphibian and Reptile Highway Crossings: State of the practice, gap analysis and decision support tool. Report prepared for the State of California, Department of Transportation, Division of Research and Innovation, Office of Materials and Infrastructure Research, June 2017.
- Langton, T.E.S., and A.P. Clevenger. 2021. Measures to Reduce Road Impacts on Amphibians and Reptiles in California. Best Management Practices and Technical Guidance. Prepared by

- Western Transportation Institute for California Department of Transportation, Division of Research and Innovation and System Information. <https://dot.ca.gov/-/media/dot-media/programs/research-innovation-system-information/documents/final-reports/ca20-2700-finalreport-a11y.pdf>
- Liang, C.T., and T.J. Stohlgren. 2011. Habitat suitability of patch types: A case study of the Yosemite toad. *Frontiers of Earth Science* 5(2):217–228.
- MacKenzie, D.I., J.D. Nichols, J.A. Royle, K.H. Pollock, L.L. Bailey, and J.E. Hines. 2017. *Occupancy estimation and modeling: inferring patterns and dynamics of species occurrence*. Elsevier. (revision from original publication 2005).
- Macpherson, M.R., J.D. Litzgus, P.J. Weatherhead, and S.C. Lougheed. 2021. Barriers for big snakes: incorporating animal behaviour and morphology into road mortality mitigation design. *Global Ecology Conservation* 26:e01471.
- Milburn-Rodríguez, J.C., J. Hathaway, K. Gunson, D. Moffat, S. Béga, and D. Swensson. 2016. Road mortality mitigation: The effectiveness of Animex fencing versus mesh fencing. <https://animexfencing.com/whyanimex/animex-vs-mesh>.
- Mills, L.S. and Allendorf, F.W. 1996. The one-migrant-per-generation rule in conservation and management. *Conservation biology*, 10(6): 1509-1518.
- Navas, C.A., F.R. Gomes, and E.A. De Domenico. 2016. Physiological ecology and conservation of anuran amphibians. *Amphibian and Reptile Adaptations to the Environment: Interplay Between Physiology and Behavior*. D.V. de Andrade, C.R. Bevier, J.E. de Carvalho, (Eds.), CRC Press, Boca Raton, Florida. p. 155–188.
- Orłowski, G. 2007. Spatial distribution and seasonal pattern in road mortality of the common toad *Bufo bufo* in an agricultural landscape of south-western Poland. *Amphibia-Reptilia* 28(1): 25–31.
- Ottburg, F.G., and E.A. van der Grift. 2019. Effectiveness of road mitigation for common toads (*Bufo bufo*) in the Netherlands. *Frontiers in Ecology and Evolution* 7: 23.
- Pacific Newt Roadkill Main Project. 2022. <https://www.inaturalist.org/projects/pacific-newt-roadkill-main-project-lexington-reservoir> (more references available)
- R Core Team. 2021. R: A language and environment for statistical computing. R Foundation for Statistical Computing, Vienna, Austria. URL <https://www.R-project.org/>.
- Rasband, W.S. 1997–2018. ImageJ,. US. National Institutes of Health, Bethesda, Maryland, USA, <https://imagej.nih.gov/ij/>.
- Royle, J.A. and Dorazio, R.M., 2008. Hierarchical modeling and inference in ecology: the analysis of data from populations, metapopulations and communities. Elsevier.
- Ruby, D.E., J.R. Spotila, S.K. Martin, and S.J. Kemp. 1994. Behavioral responses to barriers by desert tortoises: implications for wildlife management. *Herpetological Monographs* 8: 144–160.
- Rytwinski, T., and L. Fahrig. 2012. Do species life history traits explain population responses to roads? A meta-analysis. *Biological Conservation* 147(1): 87–98.

- Semlitsch, R.D. 2008. Differentiating migration and dispersal processes for pond-breeding amphibians. *Journal of Wildlife Management* 72(1): 260–267.
- Shaffer, H.B., G.M. Fellers, A. Magee, and S.R. Voss. 2000. The genetics of amphibian declines: population substructure and molecular differentiation in the Yosemite toad *Bufo canorus* (Anura, Bufonidae) based on the single-strand conformational polymorphism analysis (SSCP) and mitochondrial DNA sequence data. *Molecular Ecology* 9: 245–257.
- Trenham, P.C., W.D. Koenig, M.J. Mossman, S.L. Stark, and L.A. Jagger. 2003. Regional dynamics of wetland-breeding frogs and toads: turnover and synchrony. *Ecological Applications* 13(6): 1522–1532.
- U.S. Fish and Wildlife Service (USFWS). 2014. Endangered Species Status for Sierra Nevada Yellow-Legged Frog and Northern Distinct Population Segment of the Mountain Yellow-Legged Frog, and Threatened Species Status for Yosemite Toad; Final Rule. *Federal Register*, Vol. 29, No. 82, April 29, 2014. 81 FR 59045 59119.
- van der Ree, R., J.W. Gagnon, and D.J. Smith. 2015. Fencing: a valuable tool for reducing wildlife-vehicle collisions and funneling fauna to crossing structures. *Handbook of road ecology*, pp.159–171.
- Van Tienhoven, A.M., J.E. Den Hartog, R.A. Reijns, and V.M. Peddemors. 2007. A computer-aided program for pattern-matching of natural marks on the spotted ragged tooth shark *Carcharias taurus*. *Journal of Applied Ecology* 44, 273–280. <https://reijns.com/i3s/>.
- Vaughan, C., S. Barnes, C. Brehme, C. Liang, and C. Brown. Manuscript in prep. Spatial Analysis of Yosemite Toad Road Mortality in Sierra National Forest, California. USFS Sierra Nevada Amphibian Monitoring Program, Stanislaus National Forest, Sonora, California. cassie.vaughan@tpwd.texas.gov.
- Wickham, H, R. François, L. Henry, K. Müller. 2022. dplyr: A Grammar of Data Manipulation. <https://dplyr.tidyverse.org>, <https://github.com/tidyverse/dplyr>.
- Woltz, H.W., J.P. Gibbs, and P.K., Ducey. 2008. Road crossing structures for amphibians and reptiles: informing design through behavioral analysis. *Biological Conservation* 141, 2745–2750.
- Yamaura, Y., J.A. Royle, N. Shimada, S. Asanuma, T. Sato, H. Taki, and S.I. Makino. 2012. Biodiversity of man-made open habitats in an underused country: a class of multispecies abundance models for count data. *Biodiversity and Conservation*, 21(6), 1365–1380.
- Young, D.S. 2010. tolerance: An R Package for Estimating Tolerance Intervals, *Journal of Statistical Software*, 36(5), 1–39.

Appendix 1: Supplemental Tables for ERS Activity Analyses

Table 1. Model parameter estimates for Occupancy model community-level effects. BP is the Bayesian p-value derived from model residuals, representing how well the model explains the data, based on a Freeman-Tukey Goodness-of-fit test. Adjacent Bridge and Along Fence correspond to the two factor levels characterizing the difference in use-occurrence probability between cameras in the bridge underpass, adjacent to underpass, and in the forest. Years refer to the community-level mean effect of year on use-occurrence probability during an individual year. Camera effort refers to the effect of the number of days a camera was active on species detection probability. Camera location refers to whether a camera was located along the fence, or positioned in unfenced, underpass habitat. Seasons 2 and 3 represent the effect of whether species detection probability was different in days 1–60 of sampling, as compared to 61–120 and 121–180 respectively.

	mean	sd	L-HDI	U-HDI
BP	0.40	0.49		
<i>Occupancy Model</i>				
Adjacent Bridge	-0.67	0.59	-1.61	0.21
Along Fence	-0.54	0.69	-1.63	0.51
2019	-0.30	1.48	-2.61	1.82
2020	3.30	2.18	0.03	6.34
2021	-0.72	1.13	-2.53	0.99
<i>Detection Model</i>				
Camera Effort	2.29	0.37	1.70	2.87
Season2	0.30	0.29	-0.17	0.76
Season3	0.05	0.58	-0.90	0.94
Camera Location	1.34	0.21	0.99	1.68

Figure 2. Effect of location on the occupancy probability of amphibians, small mammals, and reptiles. Mean estimates and 90% confidence intervals are presented for 3 locations: 1) within the underpass (Under ERS-red), 2) immediately adjacent to the underpass and roadway (Adjacent to ERS-green), and 3) in the forest (Outside ERS-blue). Mean estimates are presented as filled circles, 75% confidence intervals as thicker lines and 90% confidence intervals as thin lines. The dotted horizontal line is mean occupancy for all species at all locations (log scale).

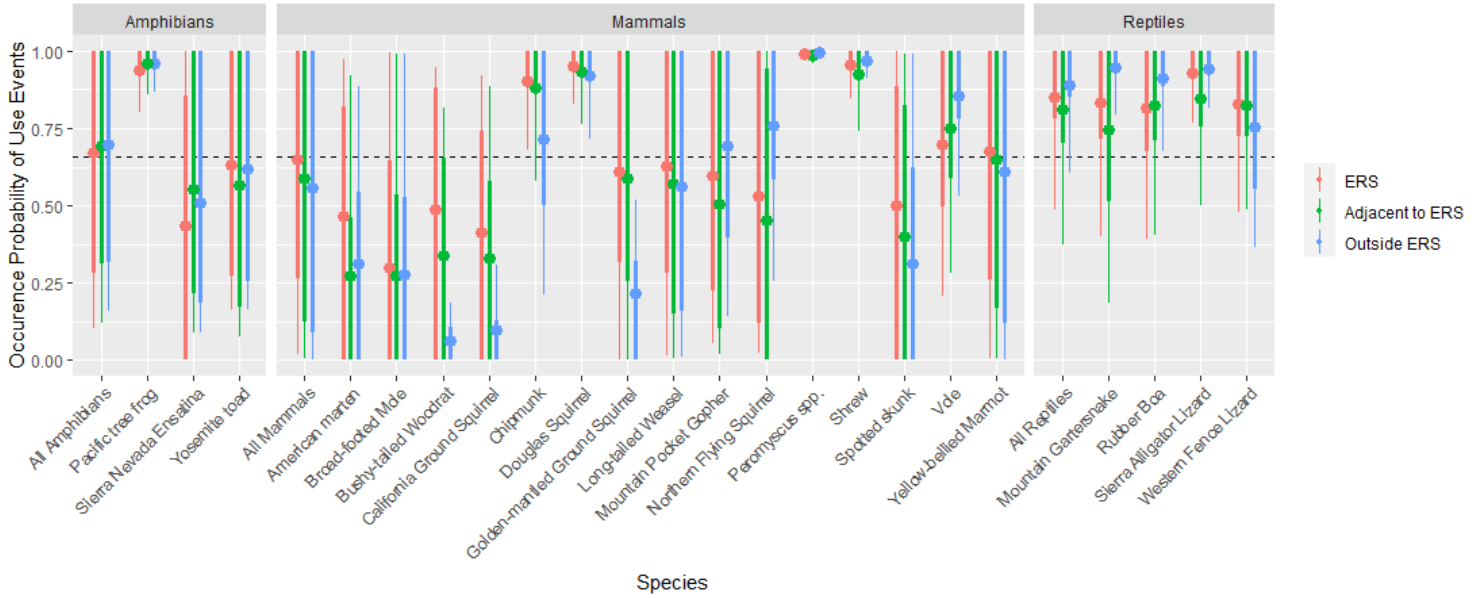

Table 2. Model parameter estimates for N-mixture model community-level effects. BP is the Bayesian p-value derived from model residuals, representing how well the model explains the data, based on a Freeman-Tukey Goodness-of-fit test. Adjacent Bridge and Along Fence correspond to the two factor levels characterizing the difference in abundance between cameras in the bridge underpass, adjacent to underpass, and in the forest. Years refer to the community-level mean effect of year on the abundance of counts during an individual year. Camera effort refers to the effect of the number of days a camera was active on individual detection probability. Camera location refers to whether a camera was located along the fence, or positioned in unfenced, underpass habitat. Seasons 2 and 3 represent the effect of whether individual detection was different in days 1–60 of sampling, as compared to 61–120 and 121–180 respectively.

	mean	sd	L-HDI	U-HDI
BP	0.43	0.50	0.00	1.00
<i>Abundance Model</i>				
Adjacent Bridge	-0.45	0.25	-0.85	-0.07
Along Fence	-0.22	0.33	-0.75	0.29
2019	-0.72	0.26	-1.11	-0.29
2020	-0.28	0.28	-0.73	0.15
2021	-0.67	0.37	-1.25	-0.08
<i>Detection Model</i>				
Camera Effort	1.44	0.28	1.01	1.89
Season2	0.20	0.31	-0.28	0.70
Season3	-0.79	0.66	-1.79	0.28
Camera Location	-0.04	0.17	-0.31	0.23

Appendix 2: Elevated Road Engineering Concept Designs and Guidance for Primary Roads and Highways

USGS WILDLIFE PASSAGE CONCEPTS EVALUATION REPORT

Prepared for:

Western Ecological Research Center
U.S. Geological Survey

Prepared by:



110 Blue Ravine Road, Suite 200
Folsom, CA 95630

Contacts:

Charles Tornaci, PE
Tel: (858) 514-8377 | Email: ctornaci@dokkenengineering.com

Sarah Holm
Tel: (916) 858-0642 | Email: sholm@dokkenengineering.com

Hanna Sheldon
Tel: (916) 858-0642 | Email: hsheldon@dokkenengineering.com

April 2022

Table of Contents

1.0	INTRODUCTION.....	3
1.1	Project Description.....	3
2.0	DESIGN COMPONENTS OF A WILDLIFE CROSSING.....	4
2.1	Main Structure	4
2.2	Turnaround Fencing and Barriers	9
2.3	Grates.....	10
2.4	Jumpouts/Ramps.....	10
2.5	Maintenance	10
3.0	PROJECT APPROVAL	11
3.1	Environmental Approval.....	11
3.2	Engineering Approval.....	13
4.0	COST CONSIDERATIONS	13
4.1	Project Approval	13
4.2	Construction.....	14
4.2.1	Type of Structure.....	15
4.2.2	Roadway Type, Location, and Landscape.....	15
4.2.3	Construction Management	16
4.3	Maintenance	16
5.0	REFERENCES.....	17

List of Appendices

A. ERS Concept Exhibits

- A.1: Pre-Cast Longitudinal Bridge Concept
- A.2: Pre-Cast Horizontal Bridge Concept
- A.3: Repeating Elevated Pre-Cast Box Culvert Concept
- A.4 Repeating Elevated Pre-Cast Abutment Short-Span Concept

List of Acronyms

AASHTO	American Association of State Highway and Transportation Officials
Caltrans	California Department of Transportation
CDFW	California Department of Fish and Wildlife
CESA	California Endangered Species Act
CEQA	California Environmental Quality Act
CFG	California Fish and Game
CFR	California Federal Regulations
Dokken	Dokken Engineering
ERS	Elevated Road Segment
FESA	Federal Endangered Species Act
NEPA	National Environmental Policy Act
NMFS	National Marine Fisheries Service
RWQCB	Regional Water Quality Control Board
USACE	United States Army Corp of Engineers
USGS	United States Geological Survey
USFS	United States Forest Service
USFWS	United States Fish and Wildlife Service

1.0 INTRODUCTION

1.1 Project Description

This Evaluation Report outlines elevated road segment wildlife passage concepts for implementation in the transportation industry. Many wildlife species, particularly migratory amphibians and turtle species, migrate between aquatic and terrestrial habitats. Prolonged lengths of roadways and roadways that intersect wildlife habitat pose a threat to migrating species, and in some cases may be the leading cause of species decline. Wildlife collision “hotspots” have been identified in many locations, both on local roads and state highway systems. This is not only a safety concern for vehicles traveling along the roadway but is greatly reducing some species populations. This increasing issue has caught attention of biologists, wildlife agencies, local Counties and cities, and the California Department of Transportation (Caltrans). A solution for safe wildlife passage is needed as transportation systems continue to be built and improved.

Preliminary studies have revealed that wildlife passages can be successful in safely allowing wildlife to move from one habitat community to another, across a road or highway. However, design of the passage matters. For instance, studies led by United States Geological Survey (USGS) and the U.S. Forest Service (USFS), suggest that tunnel mitigation systems can act to filter migratory movements of species that typically disperse over larger areas. In return, this unintentionally can result in population declines. This discovery has led to the creation of a wildlife passage prototype that consists of an 8” high elevated road segment (ERS) using road mats, typically designed to hold heavy construction equipment. The prototype was installed on top of an existing Sierra USFS Road within the migratory path of the Yosemite toad (*Anaxyrus canorus*), a federally threatened species. The ERS prototype spanned approximately 100 feet to allow for a wide crossing and to accommodate entry of both sunlight and moisture. The ERS prototype was proven to be successful in allowing the Yosemite toad, and many other small wildlife species, to safely cross the road while the road was still open to through traffic by allowing safe passage underneath the roadway along natural terrain paths.

Caltrans and other public agencies have expressed interest in how the ERS prototype concept could be adapted to higher traffic volume roads to meet Caltrans’ most current design standards, and the American Association of State Highway and Transportation Officials (AASHTO) standards, while still provide a passage for wildlife species. Dokken Engineering (Dokken) has produced four design concepts that incorporate a wildlife passage ERS with exhibits showing plans, elevations, and typical sections for the USGS. The four designs including a pre-cast longitudinal road support concept, a pre-cast horizontal road support concept, a pre-cast box culvert, and a precast abutment short span concept. These concepts aim to adapt the ERS prototype currently installed on the Sierra USFS Road to accommodate a similar ERS wildlife passage on primary roads and highways meeting the Caltrans design criteria of extended and open low-elevation passage structures.

This Evaluation Report summarizes the key design elements for the four design concepts, as well as project approval, design cost considerations, and a cost driver matrix. These concepts are intended to provide a starting point for Caltrans and other local agency engineers to design and build structures to enhance small wildlife movement, specifically amphibians, over wide stretches of roadway. These preliminary concepts require tailoring depending on project goals, project location, type of roadway, targeted species, etc. These design considerations are discussed in more detail in Section 4.

2.0 DESIGN COMPONENTS OF A WILDLIFE CROSSING

Depending on the desired height of the subterranean opening and the environmental and/or property constraints at along the proposed improvement road, ERS as presented in this report may be more feasible than an at-grade solution. To build an at-grade crossing, grading/excavation earthwork and earth retaining structures would be required to support the lower crossing elevation. Doing this kind of work would alter drainage patterns, and have a larger overall project footprint on either side of the road, which may become problematic if there are property constraints or other environmental constrictions. With an ERS, any rise in elevation may either be graded, or supported with earth retaining structures to decrease the project footprint (at the increased cost of the structures). ERS would be more prudent for existing roads in poor condition (that could qualify for additional road surface improvement funding), in areas of constrained property, areas that frequently flood, or in areas with challenging topography where excavating beyond the sides of the roads would be difficult. The following section describes the design components and maintenance considerations of the four ERS wildlife crossing concepts developed by Dokken.

2.1 Main Structure

The main structure creates a passageway for safe road crossing opportunities for a wide array of medium to small sized wildlife species. Four structure concepts were developed for wildlife crossings targeted at amphibians and/or small species that incorporate an ERS. Multiple opening points are desirable, as previous studies have indicated that many amphibians may turn away if they don't quickly find an open passageway after encountering road barrier fencing. The ERS concepts described below can be placed back-to-back, separated by at least 30 feet apart to provide either wider passage widths, or multiple entry points. Metal traffic rated bicycle grates (from Caltrans Standard Plans sheets D77A and D77B), or custom fabricated metal grates with bicycle safety features (such as meshing over the bicycle traveled way) are incorporated to allow natural light, air circulation, and moisture during rain events to reach the crossing base when most amphibians make migratory movements. Grates would be designed to the most current AASHTO Bridge Design Specifications and associated Caltrans Amendments and Caltrans Bridge Design Memorandums and guidelines. If the project location is remote, pre-fabricated concrete structural elements are encouraged to take advantage of Accelerated Bridge Construction techniques that can minimize construction duration and heavy construction traffic associated with bringing separate concrete materials and bar reinforcing steel to a project site. Since the ERS is elevated above the road, no additional

barriers are needed within the ERS footprint, although barriers leading to the ERS on either end at the terrain level are encouraged to increase use and prevent animals from accessing the ERS on either side. Addition of small overhands, or lips, on barriers is recommended for target species that may climb barrier walls.

Implementation of the culvert system should consider existing drainage patterns and facilities. This culvert system is not intended to function as a drainage catchment as fast flowing water may be detrimental to amphibian species using the crossing. A summary table listing limitations, advantages, and disadvantages of each concept is provided below the concept descriptions.

Design 1: Pre-Cast Longitudinal Bridge Concept

The pre-cast longitudinal bridge concept would consist of multiple alternating pre-cast concrete slab beams that would be placed parallel to traffic movement along the ERS travelled way to support vehicular, bicycle, and pedestrian traffic over the wildlife crossings. The pre-cast girders would be supported by concrete abutments at the ends and span over existing topography and undisturbed natural terrain. The wildlife opening in the design concept presented would be at least 1.5 feet high but can vary depending on the targeted species. As the width of the opening increases, more extensive foundations would be required.

Vehicular traffic safety barriers can be installed on the pre-cast concrete girders at the edges of travelled way to protect vehicles and bicycles from the vertical drop off between the ERS and wildlife crossing levels. Beyond the abutment supports, concrete wingwalls and earth grading can be utilized to support the elevated vehicular travelled way. Wildlife barriers can be connected to the abutments at the natural terrain level to guide amphibians towards the passageway. Metal grates, rated to support vehicular traffic, can be placed between precast girder segments to allow moisture, air circulation, and natural light to reach the terrain below which would serve as the amphibian crossing.

Pre-cast concrete girders may range anywhere from 30 feet long to 70 feet long to create a customizable opening width for wildlife passage, with an ERS structure depth ranging between 12-inches to 30-inches deep. This concept is considered a bridge by Caltrans standards (as the spans would be greater than 20 feet long), requiring semi-annual inspections by Caltrans. Wider opening widths present minimal barriers to movements along the length of the ERS, allowing for free movement under the roadway. 3-ft wide metal grates placed between the pre-cast concrete girders can be located within the middle of vehicular traffic lanes to minimize road noise caused by tire/grate contact. Due to the orientation of the pre-cast concrete girders and metal grates between girders, it may be more difficult to achieve a continuously wetted passageway for amphibians to cross, as dry spots may occur between the grated openings. However, this option minimizes road noise for highly trafficked roads and highways.

Reference Appendix A.1 for concept exhibit.

This concept has an unlimited opening length capacity and can be installed on high-capacity multi-lane freeways and expressways utilizing stage construction to maintain traffic along the proposed vehicular facility during installation of the ERS. This concept could be repeated in as many increments as desired, depending on the targeted species. The minimum length between openings for consecutive structures is approximately 12 feet, depending on the opening width. Given the pre-cast concrete slabs, this system would be suitable for a straight road alignment.

Design 2: Pre-Cast Horizontal Concept

The Transverse Pre-cast Girder bridge ERS concept would consist of alternating pre-cast concrete slab beams oriented perpendicular to the centerline of the ERS vehicular travelled way to support vehicular, bicycle, and pedestrian traffic over the wildlife crossing. This concept would require longitudinal concrete ledge seat beams at the outer edges of the ERS to support the transversely placed precast concrete girders. The ledge seat beams would be supported by concrete abutments at the ends, and span over existing topography and undisturbed natural terrain. As the width of the opening increases, more extensive foundations would be required.

Vehicular traffic safety barriers can be installed on the pre-cast concrete girders at the edges of travelled way to protect vehicles and bicycles from the vertical drop off between the ERS and wildlife crossing levels. Beyond the abutment supports, concrete wingwalls and earth grading can be utilized to support the elevated vehicular travelled way. Wildlife barriers can be connected to the abutments at the natural terrain level to guide amphibians towards the passageway. 3-ft long metal grates, rated to support vehicular traffic, can be placed between precast girder segments to allow moisture, air circulation, and natural light to reach the terrain below which would serve as the amphibian crossing.

Abutment support heights can be customized to provide as much, or as little vertical space above the natural terrain as desired for a particular wildlife species to cross. With this concept, the wildlife crossing opening width may range between 10 feet wide to 100 feet wide to create a customizable opening width for wildlife passage. Opening widths greater than 20 feet are considered a bridge by Caltrans standards, and would require semi-annual inspections by Caltrans. Wider opening widths present minimal barriers to movements along the length of the ERS, allowing for free movement under the roadway. The ledge beam depth would be dependent upon the opening length and may vary between 2 feet to 4 feet deep. With the transverse orientation of the pre-cast concrete girders, the metal grates placed between the precast concrete girders would allow for continuously wetted passageways under the ERS during rainfall events when most amphibians make migratory movements. Dry spots may occur between the grated openings, which must be spaced approximately 3-4 feet apart. The orientation of the metal grates would create additional traffic noise from vehicular tires transitioning between a concrete surface and the metal grates as vehicles pass above the wildlife crossing. **Reference Appendix A.2 for concept exhibit.**

Pre-cast concrete girders may range anywhere from 30 feet long to 70 feet long to accommodate vehicular and bicycle/pedestrian traffic capacity requirements for the ERS, which can accommodate up to four lanes of vehicular traffic with eight-foot shoulders and a single bike lane. The vehicular road width would be limited to 70 feet due to the structural capacity of pre-cast concrete slabs. For high-capacity multi-lane highways or expressways, this concept can be installed side-by-side to accommodate the required traffic lanes. This concept could be repeated in as many increments as desired, depending on the targeted species. The minimum length between openings for consecutive structures is approximately 12', depending on the opening width. Given the precast concrete slabs, this system would be ideal for a straight road alignment. With the transverse orientation of the precast concrete girders, this concept does not accommodate stage construction on narrow road widths.

Design 3: Repeating Elevated Pre-Cast Box Culvert Concept

In addition, a repeating pre-cast box culvert system can also provide a safe crossing for small wildlife. This system would be ideal on a curved road alignment, compared to the other concepts. The Pre-cast Box Culvert ERS concept would utilize pre-cast concrete box culverts oriented perpendicular to the centerline of the ERS vehicular travelled way to support vehicular, bicycle, and pedestrian traffic over the wildlife crossings. The pre-cast box culverts would be placed on over-excavated and backfilled earthwork along the length of the culvert. 3-ft long traffic-rated metal grates placed along an opening in pre-cast box girders would allow moisture, air circulation, and natural light to reach the culvert invert below which would serve as the amphibian crossing. The invert may be partially filled with soil through the opening in the culvert roof to provide a more natural terrain for wildlife to cross. Vehicular traffic safety barriers can be installed at the ends of the pre-cast concrete box culverts (at the edges of travelled way) to protect vehicles and bicycles from the vertical drop off between the ERS and wildlife crossing levels. Beyond the culvert openings, concrete wingwalls and earth grading can be utilized to support the elevated vehicular travelled way. Wildlife barriers can be connected at the culvert openings at the wildlife crossing level to guide amphibians towards the passageway.

Pre-cast Box Culvert openings can vary from 4-8 feet in width, and 2-8 feet in height to create the desired opening for the for a particular wildlife species to cross. With the transverse orientation of the precast concrete box culverts, the metal grates placed along the culvert roof will allow for a more continuously wetted passageway that would allow animals to pass through with desired level of moisture, though dry spots may occur along wider opening widths along the opening edges. The orientation of the metal grates would create additional traffic noise from vehicular tires transitioning between a concrete surface and the metal grates as vehicles pass above the wildlife crossing. **Reference Appendix A.3 for concept exhibit.**

Precast concrete box culverts are typically fabricated in 4–8-foot pieces and can be placed continuously end-on-end to accommodate any required vehicular and bicycle/pedestrian lane and shoulder configuration for the ERS. This concept allows for stage construction, as the precast box culvert pieces can be placed in single or multiple segments as needed to maintain traffic flow along a given road. Precast concrete box culverts can be placed

either side-by-side to create a wider crossing opening, or spaced as close as 8 feet apart, or as far apart as desired along its length to create multiple wildlife access points and also form a natural barrier wall between passages. The short opening width of this concept is amenable for use along curved roadway facilities.

Design 4: Repeating Elevated Pre-Cast Abutment Short-Span Concept

A short span repeating alternative utilizing pre-cast concrete abutments and a custom fabricated metal grate can be utilized to provide a safe crossing for wildlife. This system would be ideal on a curved road alignment, compared to the long-span alternative concepts. The Pre-cast Abutment ERS concept would utilize pre-cast concrete abutment oriented perpendicular to the centerline of the ERS vehicular travelled way to support a custom fabricated metal grate to support vehicular, bicycle, and pedestrian traffic over the wildlife crossings. The pre-cast abutments would be placed on over-excavated and backfilled earthwork along the width of the vehicular alignment. Custom designed and fabricated metal grates designed to support vehicular traffic placed on top of the pre-cast abutment seats would provide an opening which would allow natural light, air circulation, and moisture from rainfall to reach the natural terrain base below the ERS which would serve as the wildlife crossing. Vehicular traffic safety barriers can be installed along the opening, with the vertical barrier elements attached to pre-cast concrete wingwalls attached to the precast concrete abutments, and horizontal metal railing elements spanning between the vertical supports to provide a continuous vehicular traffic safety barrier across the opening to protect vehicles and bicycles from the vertical drop off between the ERS and wildlife crossing levels. Beyond the precast concrete abutments, precast concrete wingwalls and earth grading can be utilized to support the elevated vehicular travelled way. Wildlife barriers can be connected at the precast abutments at the face of the openings at the wildlife crossing level to guide amphibians and other wildlife towards the passageway.

The pre-cast abutment short span concept openings can vary from 4-6 feet in width, and 2-8 feet in height to create the desired opening for the for a particular wildlife species to cross. The metal grates placed along the abutment seats will allow for a continuously wetted passageway that would allow animals to pass through with the desired level of soil moisture. The orientation of the metal grates across the vehicular road width would create additional traffic noise from tire/grate contact.

Depending on the desired height of the openings, the precast concrete abutments can be fabricated in 4-ft to 8-ft lengths and can be placed continuously end-on-end to accommodate any required vehicular and bicycle/pedestrian lane and shoulder configuration for the ERS. This concept allows for stage construction, as the precast abutment supports can be placed in single or multiple segments as needed to maintain traffic flow along a given road. Precast abutment supports can be spaced as close as 8 feet apart, or as far apart as desired along its length to create multiple wildlife access points and also form a natural barrier wall between passages. The precast concrete support system can also be expanded to include intermediate piers to create a longer opening width if desired. **Reference Appendix A.4 for concept exhibit.**

ERS Concept Summary

ERS Concept Alternative	Features	Advantages	Disadvantages
Longitudinal Precast Girders	<ul style="list-style-type: none"> • 30'-70' Wide Openings • Unlimited Length • Straight Alignment • Natural Terrain Bottom 	<ul style="list-style-type: none"> • Stage Construction Permissible • Minimal Road Noise • Enhanced Variety of Opening Heights 	<ul style="list-style-type: none"> • Increased Cost/SF • Enhanced Foundation Requirements • Non-Continuous Wetted Passageway
Transverse Precast Girders	<ul style="list-style-type: none"> • 10'-100' Openings • 70' Maximum Length (can be placed end to end for additional length) • Straight Alignment • Natural Terrain Bottom 	<ul style="list-style-type: none"> • Continuous Wetted Passageway • Enhanced Variety of Opening Heights 	<ul style="list-style-type: none"> • Increased Cost/SF • Enhanced Foundation Requirements • Increased Road Noise • No Stage Construction
Repeating Elevated Pre-cast Box Culvert	<ul style="list-style-type: none"> • 4'-8' Openings • Unlimited Length • Curved or Straight Alignment • Filled Soil Bottom 	<ul style="list-style-type: none"> • Stage Construction Permissible • Continuous Wetted Passageway • Lower Cost/SF • Lower Foundation Requirements 	<ul style="list-style-type: none"> • Increased Road Noise • Limited Opening Dimensions
Repeating Elevated Pre-cast Abutments with Short Span Metal Grates	<ul style="list-style-type: none"> • 4'-6' Openings • Unlimited Length • Curved or Straight Alignment • Natural Terrain Bottom 	<ul style="list-style-type: none"> • Stage Construction Permissible • Continuous Wetted Passageway • Lower Cost/SF • Lower Foundation Requirements 	<ul style="list-style-type: none"> • Increased Road Noise • Limited Opening Dimensions

2.2 Turnaround Fencing and Barriers

Fencing is a critical component of a successful strategy involving ERS, for the purpose of wildlife crossings, because it deters animals from entering the highway or roadway and directs them toward the undercrossing. In general turnaround fencing runs parallel to the roadway and should be installed at each corner of the ERS. Depending on the targeted species, the fence should be 1' high and may require a lip to deter amphibian species that attempt to climb the fence.

Permanent material options for turnaround fencing include smooth concrete, steel, heavy duty plastic or high-density polyethylene (HDPE) or polyethylene high-density material (PEHD). Plastics would need to be attached to permanent supports. A continuous fence could be placed in between consecutive ERS segments.

Additionally, barrier walls may be required if the ERS results in a vertical drop from the roadway. The barrier must be at least 3' high on a traffic only road to comply with Caltrans' standards (Caltrans Standard Concrete Barriers B11-79/80, and B11-75-80). The type of barrier/guardrail will depend on speed and geometry of the roadway.

In some cases, if the ERS is long enough to encompass the entire migratory pathway, an extra barrier wall on each side of the ERS may not be warranted. If barrier walls are not required, amphibian turnarounds leading to the ERS on each side is preferred. The height of these turnarounds should be between 18"-36" but may vary depending on the species.

2.3 Grates

Light and moisture are key elements required for the ERS design concepts to encourage amphibian species to utilize the crossing. All four design concepts incorporate metal grates on top of the roadway to allow light, air circulation, and moisture to enter the undercrossing. The grates are made of welded steel and are bicycle proof by way of reticulate meshing and/or additional cross bars. Three of the four concepts incorporate Caltrans standard bicycle proof grates (Caltrans Standard Plan D77A/B), while the final concept would utilize a custom designed grate. Several grates would be placed in series along the length or width of the opening (depending on ERS concept). Each grate would provide approximately 3 feet of opening to allow natural light and moisture to reach the crossing. This grate is removable and would allow for access to the crossing level for maintenance purposes, if necessary. Removal of the grates for maintenance work would require partial lane closures.

2.4 Jumpouts/Ramps

Jump-outs are usually integrated with fencing and are designed to allow animals to escape back into habitat if they end up on the wrong side of the fence. Jumpouts and/or ramps could be implanted between ERS concepts as necessary.

2.5 Maintenance

Maintenance is an important consideration when designing an ERS, since each ERS concept allows for natural light and moisture to enter the undercrossing. Overtime, this may result in vegetation growth, which in turn can inhibit the use of the undercrossing by amphibian species. Road debris may also clog the grates, diminishing the passage of moisture, air circulations, and moisture from reaching the base below. Maintenance of the undercrossing, including debris, trash and vegetation removal should be conducted periodically depending on severity of buildup.

Maintenance will be site specific with consideration to traffic volumes, location, type of vegetation, time of year and potential for encountering special status species. Options to deter vegetation growth include use of herbicide (non-toxic to wildlife), placement of wood chips, sand or small gravel, and geotextile fabrics below the passage to deter deep rooting of vegetation. However, maintaining a natural bottom in the undercrossing is vital to promote crossing by amphibian species.

3.0 PROJECT APPROVAL

3.1 Environmental Approval

Appropriate environmental approval would be required prior to construction any of the ERS concepts. Environmental approval may include clearance under the National Environmental Policy Act (NEPA) and the California Environmental Quality Act (CEQA) permits for impacts to waters of the State or U.S. and permits for any potential impacts to state or federally listed species. The following is a brief description of environmental processes to considered before implementation of an ERS.

California Environmental Quality Act

The CEQA is a State law created to inform governmental decision-makers and the public about the potential, significant environmental effects of proposed activities and to work to reduce these negative environmental impacts.

National Environmental Policy Act

The NEPA provides an interdisciplinary framework for environmental planning by Federal agencies and contains action-forcing procedures to ensure that Federal agency decision makers take environmental factors into account. NEPA applies whenever a Federal agency proposes an action, grants a permit, or agrees to fund or otherwise authorize any other entity to undertake an action that could possibly affect environmental resources.

Section 401 Water Quality Certification

The Regional Water Quality Control Board (RWQCB) has jurisdiction under Section 401 of CWA and regulates any activity which may result in a discharge to Waters of the U.S. The RWQCB also asserts authority over “waters of the State” under waste discharge requirements pursuant to the Porter-Cologne Water Quality Control Act.

Section 404 Permit

The United States Army Corp of Engineers (USACE) regulates discharges of dredged or fill material into waters of the U.S., which include those tidal and non-tidal waters listed in 33 Code of Federal Regulations (CFR) 328.3 These waters include wetlands and non-wetland bodies of water that meet specific criteria, including a direct or indirect connection to interstate commerce. USACE regulatory jurisdiction pursuant to Section 404 of the CWA is founded on a connection, or nexus, between the water body in question and interstate commerce. This connection may be direct (through a tributary system linking a stream channel with traditional navigable waters used in interstate or foreign commerce) or may be indirect (through a nexus identified in USACE regulations).

Section 1602: Streambed Alteration Agreement

Under CFG Code 1602, public agencies are required to notify CDFW before undertaking any project that would “divert or obstruct the natural flow of, or substantially change or use any material from the bed, channel, or bank or, any river, stream, or lake, or deposit or dispose of debris, waste, or other material containing crumbled, flaked, or ground pavement where it may pass into any river, stream, or lake.” Preliminary notification and

project review generally occurs following the environmental review phase. When an existing fish or wildlife resource may be substantially adversely affected, CDFW is required to propose reasonable project changes to protect the resources. These modifications are formalized in a Streambed Alteration Agreement that becomes part of the plans, specifications, and bid documents for the project.

Federal Endangered Species Act

The Federal Endangered Species Act (FESA) of 1973 (16 United States Code [U.S.C.] section 1531 et seq.) provides for the conservation of endangered and threatened species listed pursuant to Section 4 of the Act (16 U.S.C. section 1533) and the ecosystems upon which they depend. These species and resources have been identified by the United States Fish and Wildlife Services (USFWS) or the National Oceanic and Atmospheric Administration National Marine Fisheries Service (NMFS).

California Endangered Species Act

The California Endangered Species Act (CESA) (California Fish and Game (CFG) Code Section 2050 et seq.) requires the CDFW to establish a list of endangered and threatened species (Section 2070) and to prohibit the incidental taking of any such listed species except as allowed by the Act (Sections 2080-2089). In addition, CESA prohibits take of candidate species (under consideration for listing).

CESA also requires CDFW to comply with CEQA (Pub. Resources Code Section 21000 et seq.) when evaluating incidental take permit applications (CFG Code Section 2081(b) and California Code Regulations, Title 14, section 783.0 et seq.), and the potential impacts the Project or activity for which the application was submitted may have on the environment. CDFW's CEQA obligations include consultation with other public agencies which have jurisdiction over the Project or activity [California Code Regulations, Title 14, Section 783.5(d)(3)]. CDFW cannot issue an incidental take permit if issuance would jeopardize the continued existence of the species [CFG Code Section 2081(c); California Code Regulations, Title 14, Section 783.4(b)].

Anticipated ERS Improvement Plans and Reports

<u>Discipline</u>	<u>Items</u>
Civil	Typical Sections, Vertical Profiles, Horizontal Alignments, Construction Details, Contour Grading, Utility Plans, Signing and Striping Plans, Traffic Signals and Lighting Plans, Electrical Details, Traffic Management Plan (Caltrans Specific)
Drainage	Drainage Report, Stormwater Pollution and Prevention Plan, Drainage Plans and Profiles, Drainage Details
Landscaping	Landscaping Plans and Irrigation Details
Structures	ERS Crossing Structure Plans, Earth Retaining Walls, Amphibian Barriers
Geotechnical	Geotechnical Design Report, Structure Foundation Report, Log of Test Borings

3.2 Engineering Approval

ERS concept proposed along vehicular traffic infrastructure open to the public will require Engineering Studies, Plans, and Specifications. Engineering Studies and Designs must meet Caltrans' standards for Caltrans facilities and Local Assistance projects. Projects on local roadways, with no Caltrans involvement, must meet the American Association of State Highway and Transportation Officials (AASHTO) standards. Studies may include geotechnical investigations (Geotechnical Design Report or Structures Foundation Report), hydraulics investigations (Location Hydraulic Study or Bridge Design Hydraulics Study), drainage studies (Drainage Report and Stormwater Pollution Prevention Plan), as well as traffic studies and a traffic control plan. Non-Standard ERS concepts will require structural design calculations to support the design of the customizable ERS system. Approval of a Traffic Control Plan (TMP) for construction, whether it be stage construction, or full road closure on Caltrans' facilities, like a highway, requires approval from Caltrans.

4.0 COST CONSIDERATIONS

4.1 Project Approval

Project approval documents, including Environmental Studies and Reports, Engineering Studies, and the preparation of project Plans, Specifications, and Estimates, are dependent upon the funding source, jurisdictional agency, overall project size and location. In general, project administration and approval documents can range between 25% - 35% of the anticipated construction cost. A cost comparison table is provided on the following page detailing cost drivers and project approval components.

Environmental & Design Comparative Project Costs

<u>Factors for Lower End of Cost Range</u>	<u>Factors for Higher End of Cost Range</u>
Larger Project Footprint	Small Project Footprint
Local Funding Only	Whole or Partial Federal Funding
Low Environmental Constraints	Environmental Constraints requiring mitigation and permits
	Sensitive Habitats, Federally Endangered Species
	Presence of Cultural Resources
Short Span ERS Crossings	Long Span ERS Crossings requiring enhanced Foundation Investigations and Structural Design
No Stage Construction/Closed Facility	

<u>Itemized Tasks</u>	<u>Cost Range</u>	<u>Remarks</u>
Local Agency Support	10% - 15% CON	Project Management Costs
Environmental Studies	\$100k - \$400k	Includes Environmental Document, Biological Assessment
Engineering Fee	15% - 20% CON	Includes Topographic Survey, Civil, Geotechnical, Water Quality, Structural Engineering, and Engineering Support During Construction

4.2 Construction

Construction costs for any ERS project will be the main driver for the overall project cost. Larger project footprints will generally have lower construction costs per square foot, as the contractor mobilization, labor, and equipment can be spread out across a larger footprint. Other factors affecting the construction cost are: Length of ERS openings, site geography, location, stage construction, and environmental constraints.

Each ERS concept differs in terms of constructability approach. Accelerated Bridge Construction (ABC) techniques could be implemented for each concept, which is more ideal for a Caltrans highway facility that may require traffic control or temporary closures, as well as remote areas where cast-in-place concrete would not be a feasible solution due to the proximity of nearby concrete batch plants. Utilizing ABC would allow individual ERS structures to be built in 3-5 days given favorable existing soil conditions, site access for construction equipment, and with a full road closure implemented. A table summarizing comparative construction costs is provided below.

Construction Comparative Project Costs

<u>Factors for Lower End of Cost Range</u>	<u>Factors for Higher End of Cost Range</u>
Larger Project Footprint	Small Project Footprint
Shorter ERS Opening Width	Longer ERS Opening
Fill Soils Available on Site	Import-Borrow for Fill Soils
Competent Site Soils	Poor Site Soils
Low Environmental Constraints	Environmental Constraints
Site near Urbanized Location	Remote Site Location
Short Duration Project	Multi-Season Project
No Stage Construction	Stage Construction/Traffic Handling

<u>Itemized Tasks</u>	<u>Cost Range</u>	<u>Remarks</u>
Road Improvements	\$26/SF - \$38/SF (Includes spaces between structures)	Includes Raising Roadway, Traffic Handling/Staging, Drainage, Amphibian Barriers, Lighting/Signals, and Safety Improvements
ERS Bridge Structures	\$250/SF - \$350/SF (Structure only)	Includes Foundation Improvements/Preparation, Structural Concrete Supports and Span Elements, Vehicular Safety Railing, and Steel Grates
ERS Repeating Culvert and Short Span Structures	\$250/SF - \$350/SF (Structure only) \$75/SF - \$100/SF (Structure + Road Improvements with structures spaced at 30 ft apart)	Structure Includes Foundation Improvements/Preparation, Structural Concrete Supports and Span Elements, Vehicular Safety Railing, and Steel Grates
Construction Management	10% - 15% CON	Includes Construction Inspection and Documentation, Materials Submittal Reviews, As-Built Documentation

4.2.1 Type of Structure

Although the ERS concepts are roughly comparable in terms of construction costs per square foot, there are details about each structure, especially size and project extent, which could drive costs up.

Pre-Cast Longitudinal and Horizontal Bridge Concept

For the pre-cast beam concepts, if the structure extends beyond 20' the structure would be considered a bridge per Caltrans' standards, requiring a bridge number and semi-annual inspections. Additionally, for the pre-cast beam concepts as the width of the opening increases, the more extensive the end support foundations will be, which will increase the overall cost of the structure. Longer/Wider pre-cast structural elements will similarly have a greater fabrication and delivery cost. Should only single or limited number of structures be desired, the cost per square foot for ERS improvements will increase.

Repeating Elevated Pre-Cast Box Culvert

Cost drivers for pre-cast box culvert systems include the height of the culvert, the higher the culvert the more material required, which would increase the overall cost of the structure. As with the pre-cast longitudinal and horizontal concepts, shorter or singular culvert lengths will have higher costs per square foot for fabrication and delivery. Costs for improvements between culverts and embankment work beyond culverts are much lower (earthwork and road section improvements only).

Repeating Elevated Pre-Cast Abutment Short-Span Concept

The main cost driver for short span precast abutment systems is the height of the opening. Taller opening heights would require more material for the precast abutment supports, and larger footings to accommodate the horizontal soil loading, which would increase the overall cost of the structure. As with the other feasible concepts, singular openings will have higher costs per square foot for fabrication and delivery. Costs for improvements between culverts and embankment work beyond culverts are much lower (earthwork and road section improvements only).

4.2.2 Roadway Type, Location, and Landscape

Approach road improvements leading up to the ERS structures may require varying amounts of earthwork to facilitate wildlife crossings, based on approach road horizontal alignment, vertical profile, and right-of-way and environmental constraints that may affect construction. Poor existing soil conditions may require additional ground improvements to meet minimum AASHTO vehicular standards. Roads and highways falling within Caltrans jurisdiction will require enhanced design requirements to meet Caltrans standards for Traffic Index (TI) for truck traffic. Local Agencies may additionally have their own criteria for TI based on anticipated traffic volume and makeup.

Approach and decent vertical slopes to and from elevated road segments would need to conform to AASHTO guidelines for vertical profiles, taking into consideration the unique horizontal geometry, design speed, site distances, and existing intersections of connecting roads to the existing road alignment to be modified. Additional road signage may be required to notify vehicular traffic of unfamiliar road features or hazards in conformance to current AASHTO design standards.

Landscaping to repair/supplement natural vegetation disturbed by construction should be considered. Native plants that compliment the target fauna and don't require supplemental irrigation are considered ideal for construction of ERS concepts.

4.2.3 Construction Management

Construction Management supervision, inspections, and documentation are necessary to ensure that the construction activities are in compliance with the environmental documents and supporting project reports, that project elements are built according to project plans and specification, and that any unanticipated site conditions or additional materials and/or labor are appropriately documented for a final reconciliation of the construction cost. Depending on funding source, additional documentation may be required to ensure the construction contractor conforms to local or Federal prevailing wage rates.

4.3 Maintenance

Yearly maintenance of the undercrossing, specifically vegetation and debris removal, would be required to allow access for wildlife species. Maintenance responsibilities would fall on the owner of the facility. Maintenance access would occur from either the sides (ends) of the opening, or roadway by removing the grate systems if necessary. This may require a full or partial road closure depending on the orientation of the grate systems. Application of a non-toxic herbicide, safe for use around aquatic habitat, may help control vegetation growth.

5.0 REFERENCES

- ASSHTO. 2018. Geometric Design of Highways and Streets.
- Brehme, C.S., S.A. Hathaway, and R.N. Fisher. 2018. An objective road risk assessment method for multiple species: ranking 166 reptiles and amphibians in California. *Landscape Ecology* 33(6): 911–935.
- Brehme, C.S., and R.N. Fisher. 2020. Research to Inform Caltrans Best Management Practices for Reptile and Amphibian Road Crossings. USGS Cooperator Report to California Department of Transportation, Division of Research, Innovation and System Information, 65A0553. <https://dot.ca.gov/-/media/dot-media/programs/environmental-analysis/documents/final-caltrans-usgs-report-herproadresearch-rev.pdf>
- Brehme, C.S., J.A. Tracey, B.A. Ewing, M.T. Hobbs, A.E. Launer, T.A. Matsuda, E.M.C. Adelsheim, and R.N. Fisher. 2021. Responses of migratory amphibians to barrier fencing inform the spacing of road underpasses: a case study with California tiger salamanders (*Ambystoma californiense*) in Stanford, CA, USA. *Global Ecology and Conservation*, 31, p.e01857.
- Caltrans. 2018. Standard Plans and Standard Specifications.
<<https://dot.ca.gov/programs/design/ccs-standard-plans-and-standard-specifications>>
- Infrastructure & Ecology Network Europe. 2020. Maintenance of ecological assets on transport linear infrastructure. <https://handbookwildlifetraffic.info/10-maintenance/10-3-maintenance-requirements-for-ecological-asset-and-wildlife-management/>
- Ottburg, F.G., and E.A. van der Grift. 2019. Effectiveness of road mitigation for common toads (*Bufo bufo*) in the Netherlands. *Frontiers in Ecology and Evolution* 7: 23.
- U.S. Department of Transportation Federal Highway Administration. 2008. Wildlife-Vehicle Collision Reduction Study.
<https://www.fhwa.dot.gov/publications/research/safety/08034/08034.pdf>
- Langton, T.E.S. and A.P. Clevenger. 2021. Measures to Reduce Road Impacts on Amphibians and Reptiles in California. Best Management Practices and Technical Guidance. Prepared by Western Transportation Institute for California Department of Transportation, Division of Research, Innovation and System Information.
<https://dot.ca.gov/-/media/dot-media/programs/research-innovation-system-information/documents/final-reports/ca20-2700-finalreport-a11y.pdf>

Appendix A: ERS Concept Exhibits

Appendix A.1: Pre-Cast Longitudinal Bridge Concept

DIST	COUNTY	ROUTE	POST MILES TOTAL PROJECT

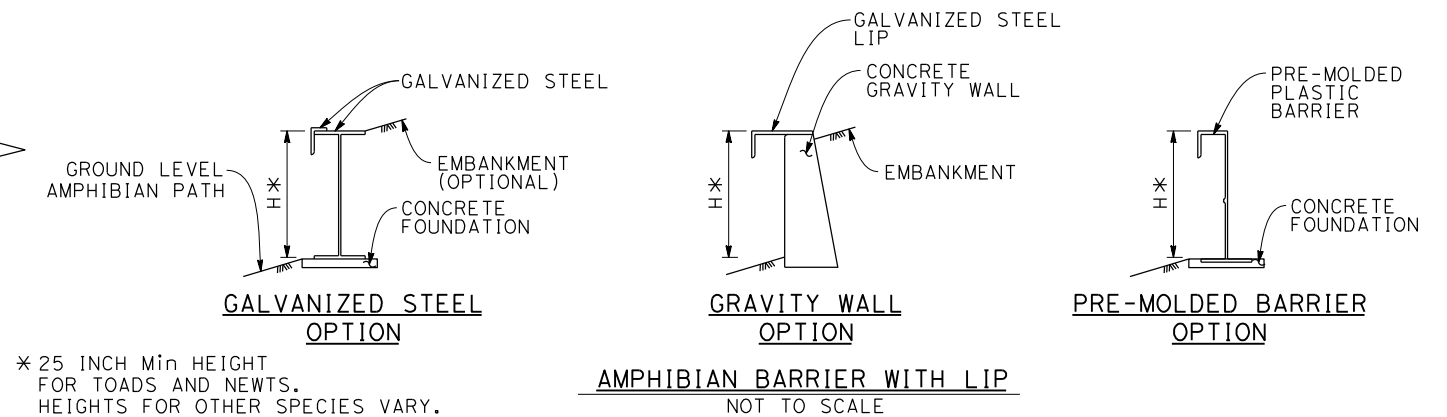
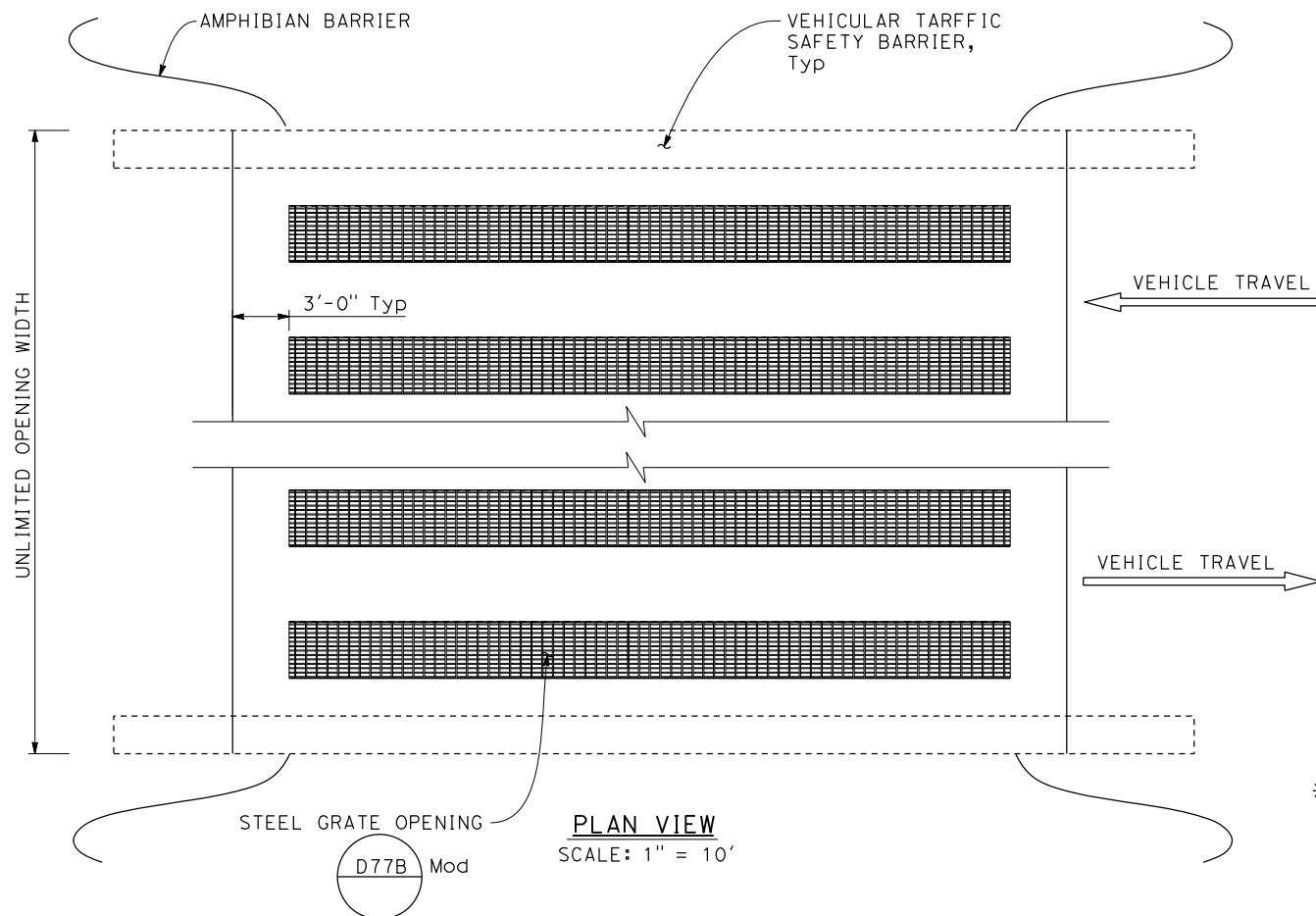
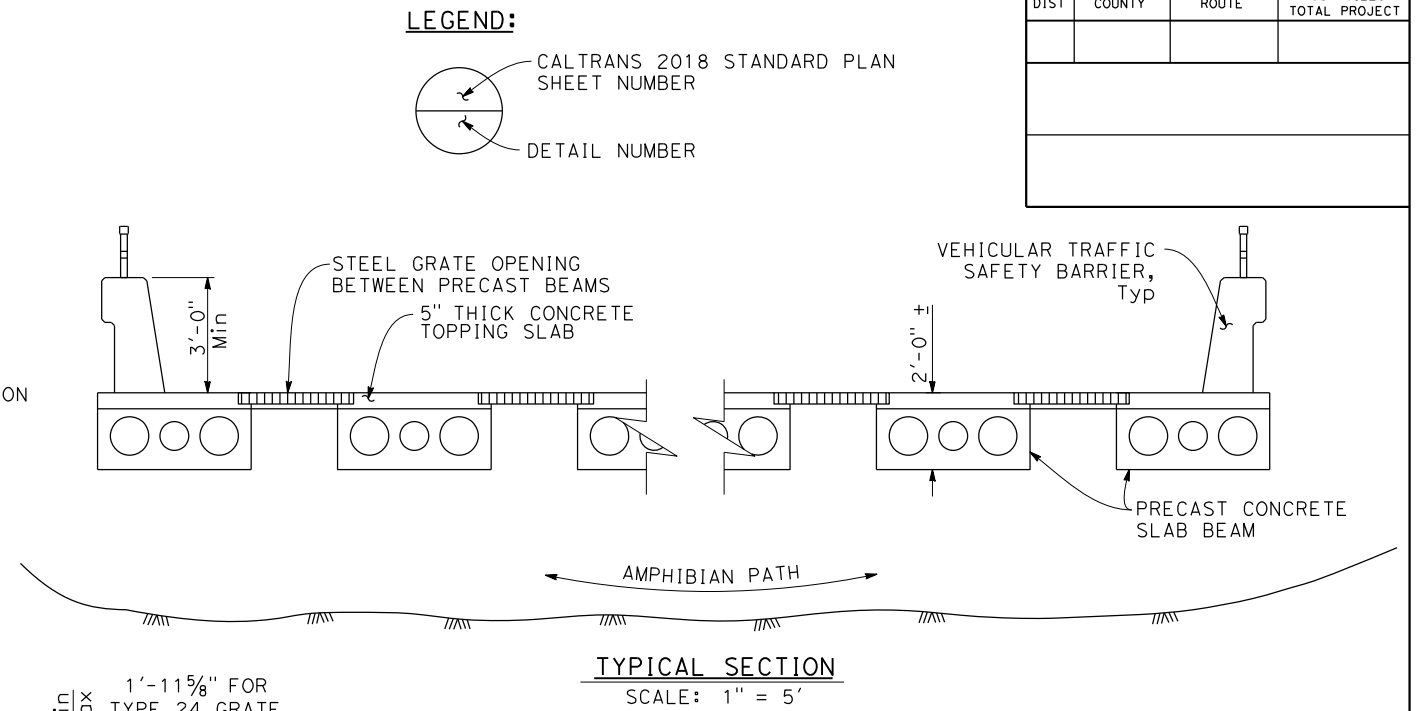
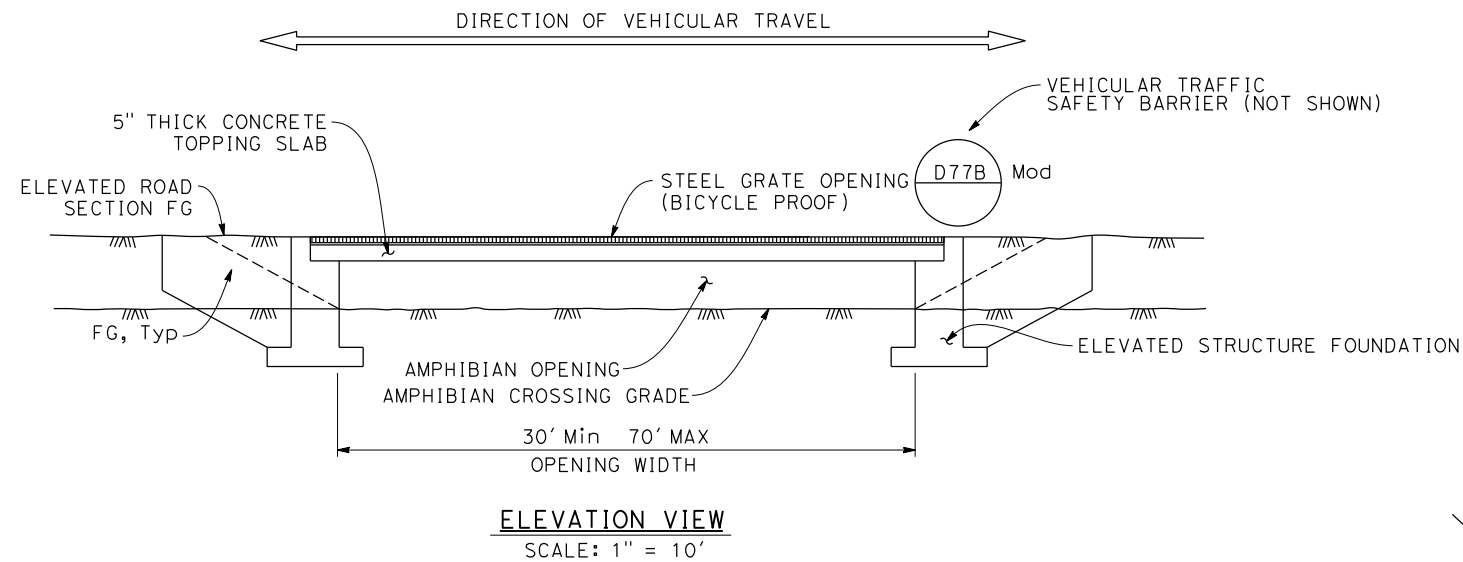

DESIGN OVERSIGHT	
SIGN OFF DATE	

DESIGNED BY	DATE
DRAWN BY	DATE
CHECKED BY	DATE
APPROVED	DATE

PROJECT ENGINEER

PLANNING CONCEPT	
USGS-AMPHIBIAN CROSSING	
BRIDGE NO.	UNIT:
SCALE:	PROJECT NUMBER & PHASE:



Appendix A.2: Pre-Cast Horizontal Bridge Concept

DIST	COUNTY	ROUTE	POST MILES TOTAL PROJECT

LEGEND:

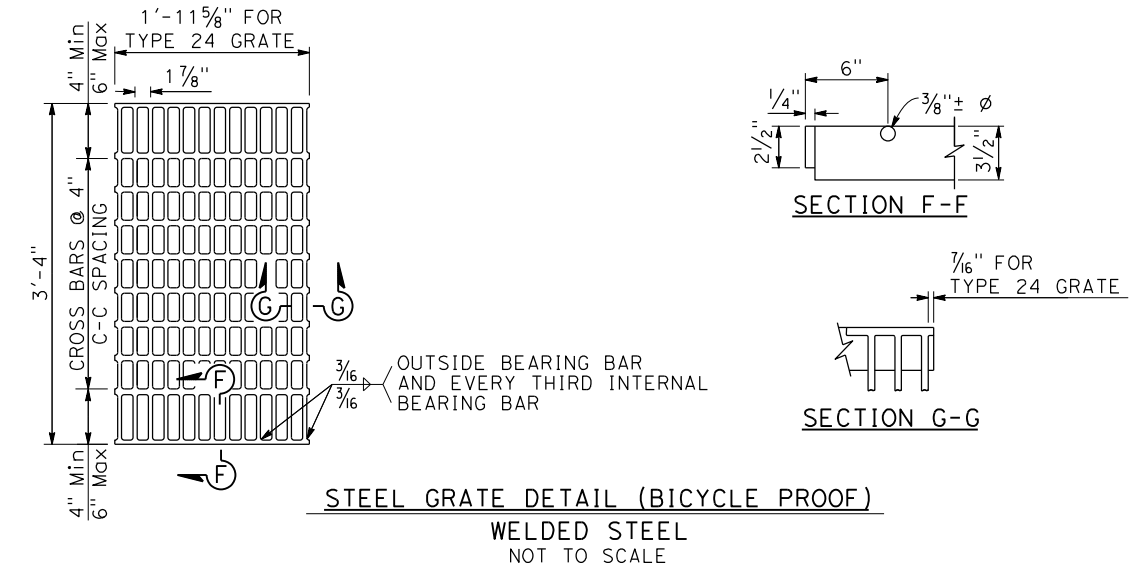
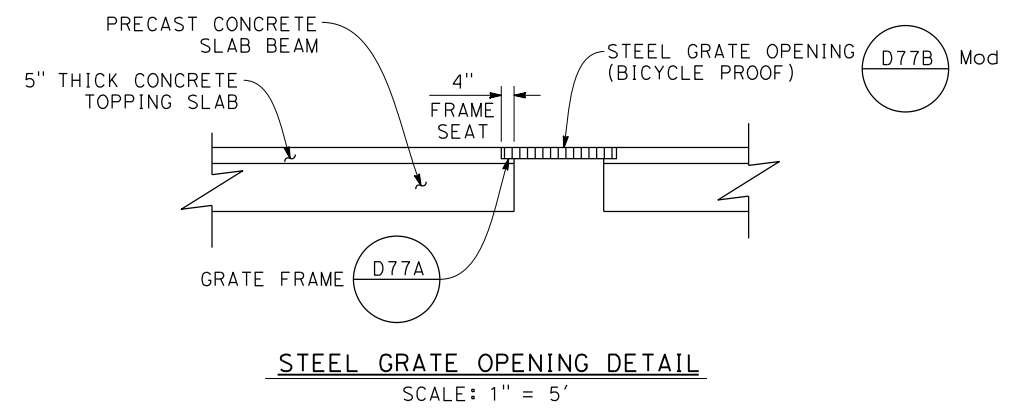
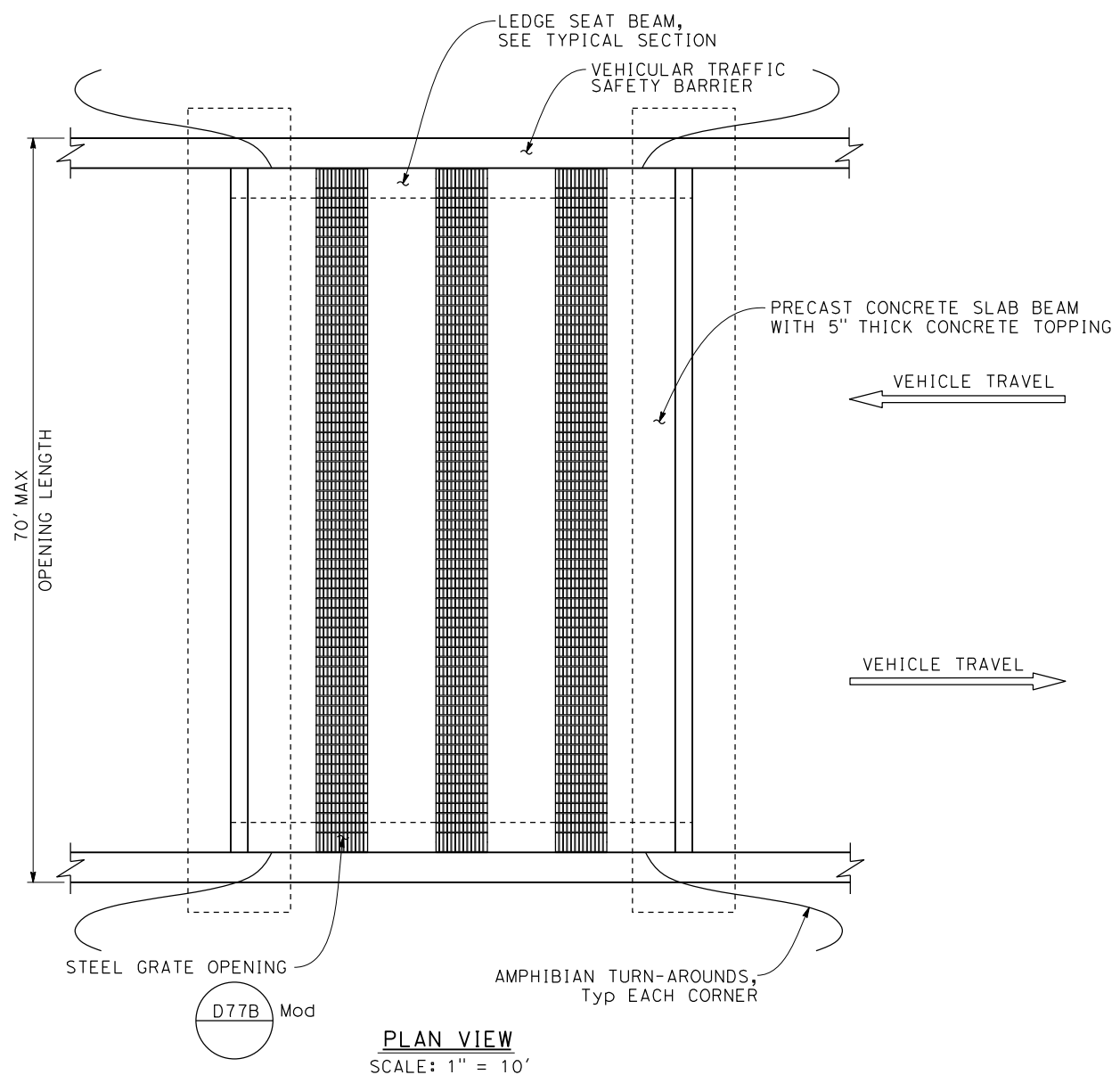
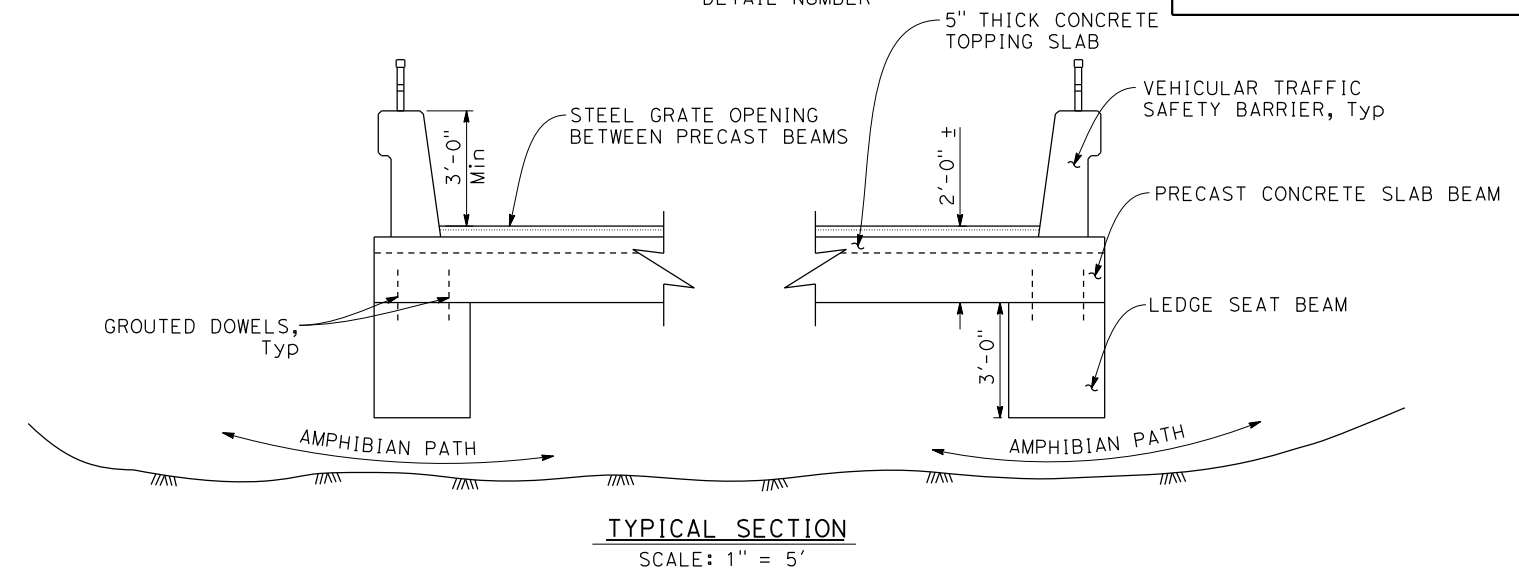
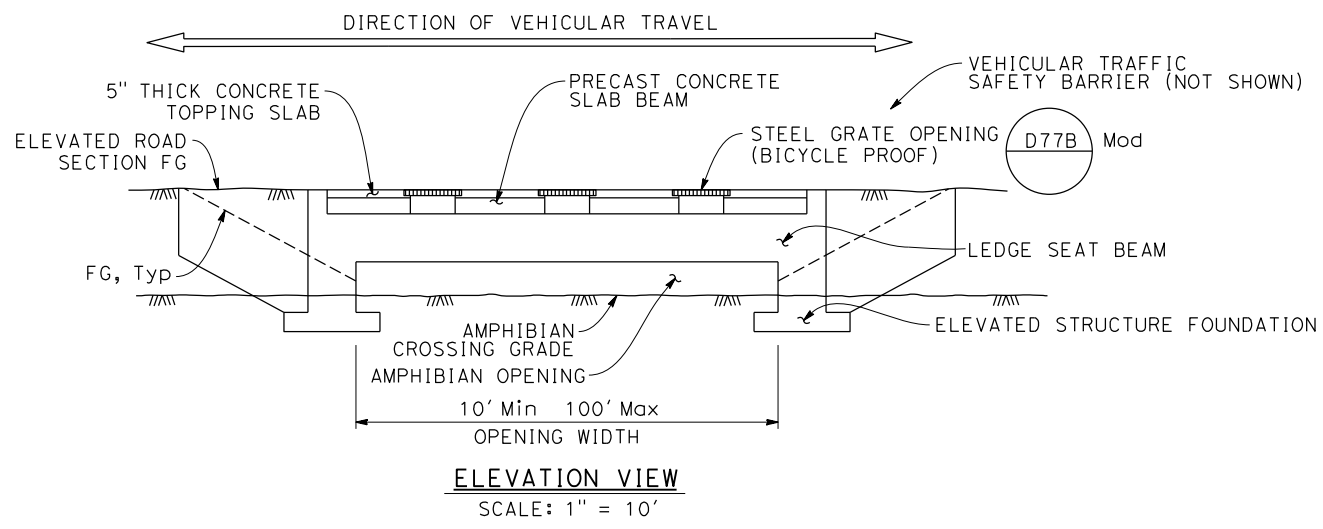
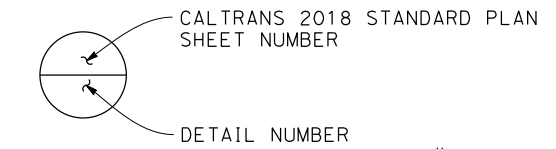

DESIGN OVERSIGHT	
SIGN OFF DATE	

DESIGNED BY	DATE
DRAWN BY	DATE
CHECKED BY	DATE
APPROVED	DATE

PLANNING CONCEPT	
USGS-AMPHIBIAN CROSSING	
BRIDGE NO.	UNIT:
SCALE:	PROJECT NUMBER & PHASE:



Appendix A.3: Repeating Elevated Pre-Cast Box Culvert Concept

DIST	COUNTY	ROUTE	POST MILES TOTAL PROJECT

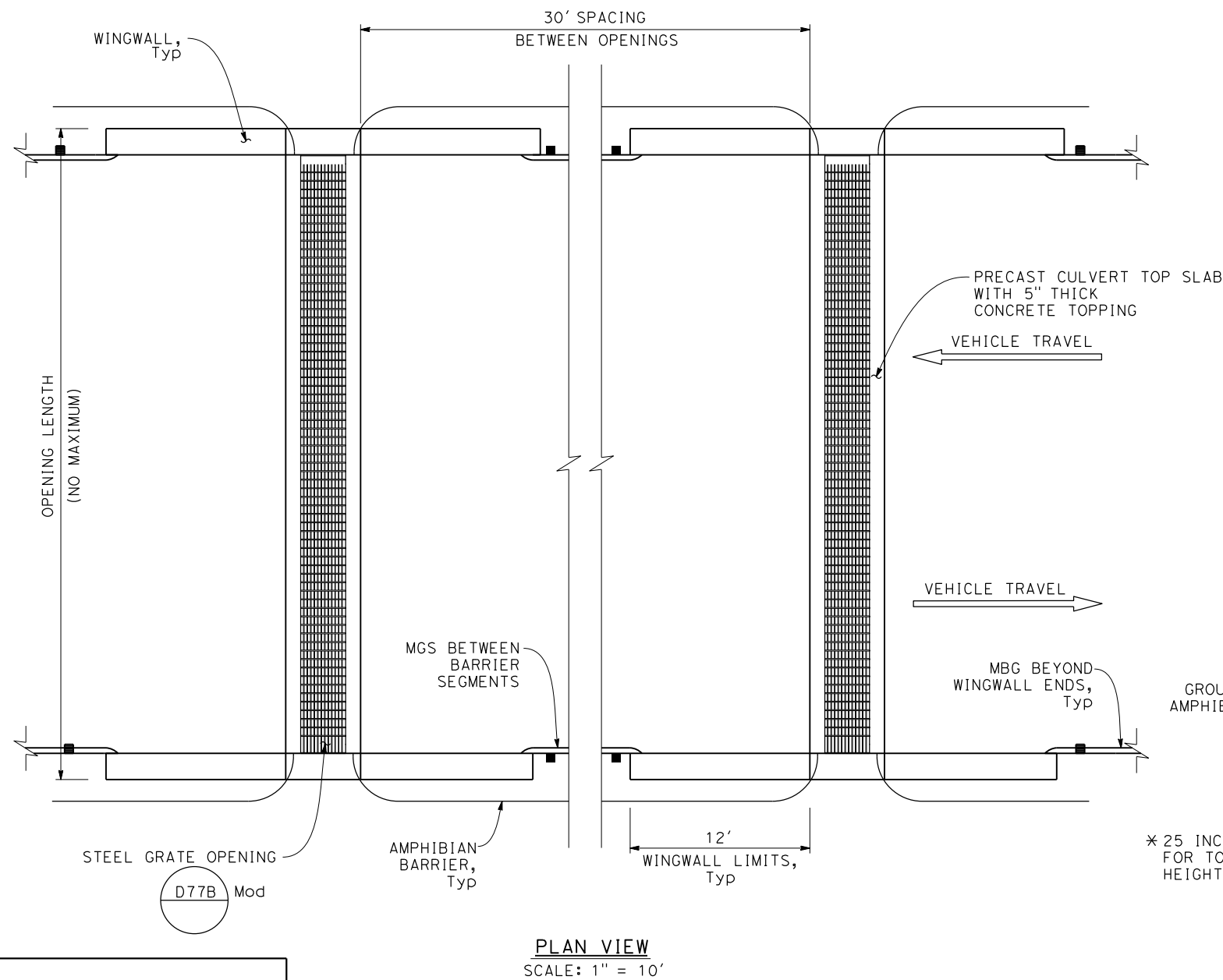
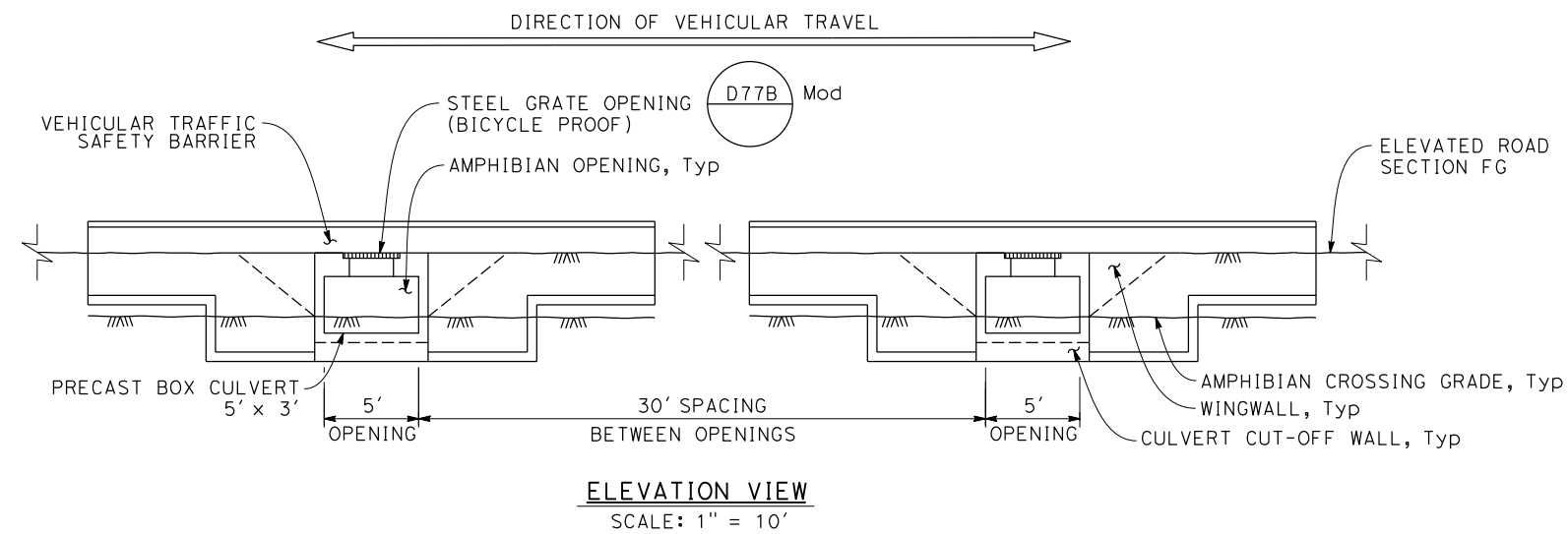

DESIGN OVERSIGHT
SIGN OFF DATE

PLAN VIEW
SCALE: 1" = 10'

LEGEND:

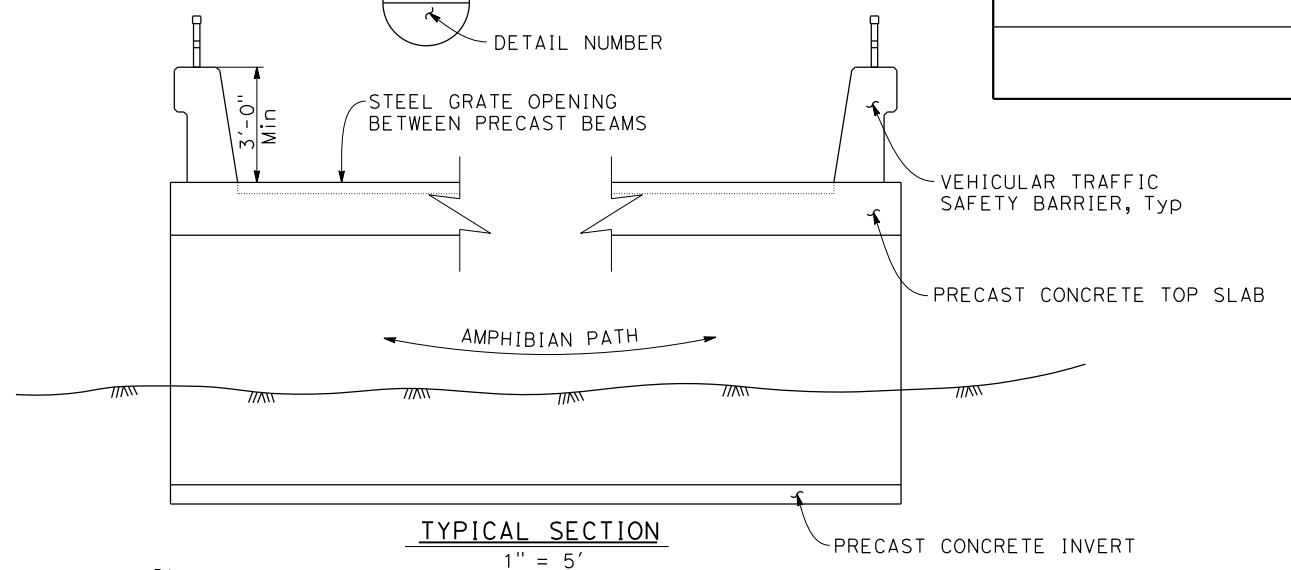
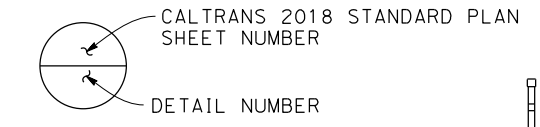

TYPICAL SECTION
1" = 5'

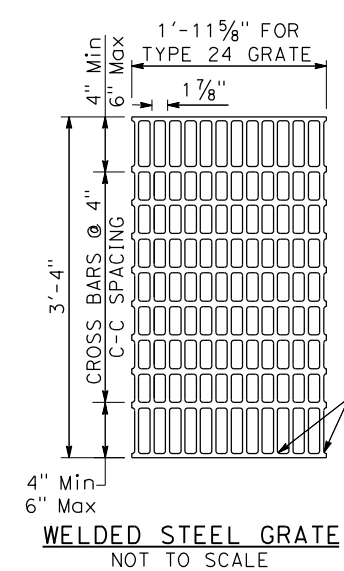

STEEL GRATE DETAILS (BICYCLE PROOF)
NOT TO SCALE

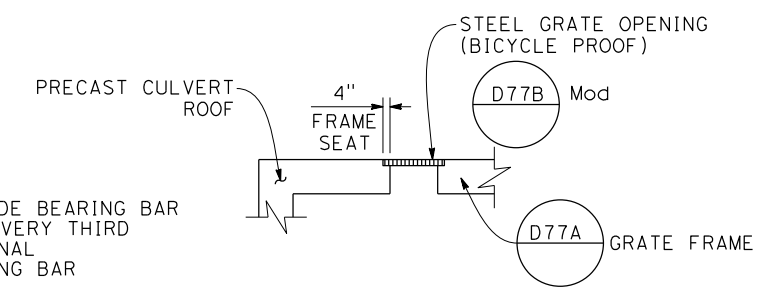

STEEL GRATE OPENING DETAIL

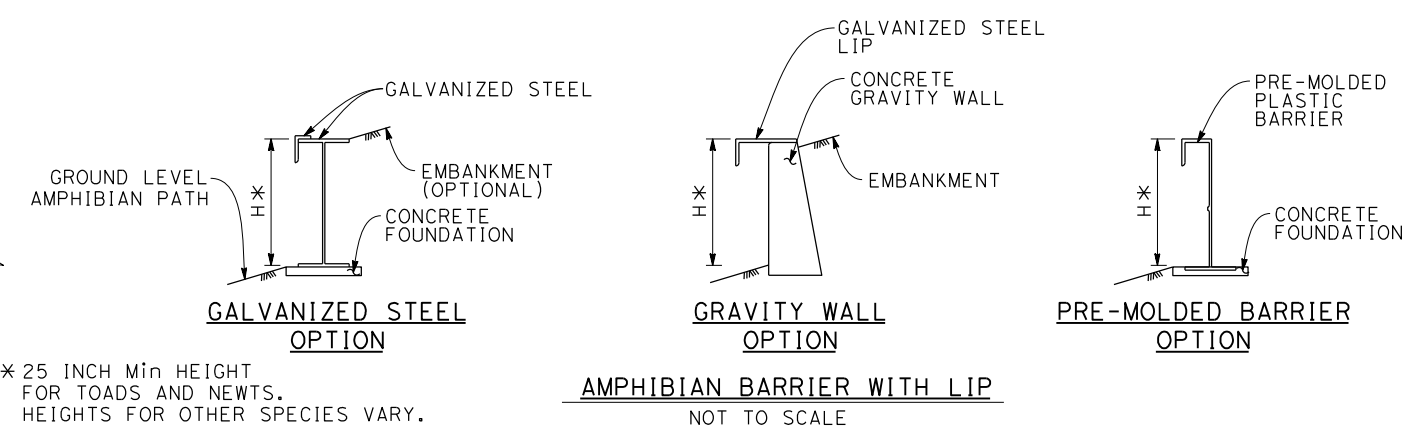

DESIGNED BY	DATE	PROJECT ENGINEER
DRAWN BY	DATE	
CHECKED BY	DATE	
APPROVED	DATE	

PLANNING CONCEPT	
USGS-AMPHIBIAN CROSSING	
BRIDGE NO.	UNIT:
SCALE:	PROJECT NUMBER & PHASE:



Appendix A.4: Repeating Elevated Pre-Cast Abutment Short-Span Concept

DIST	COUNTY	ROUTE	POST MILES TOTAL PROJECT

LEGEND:

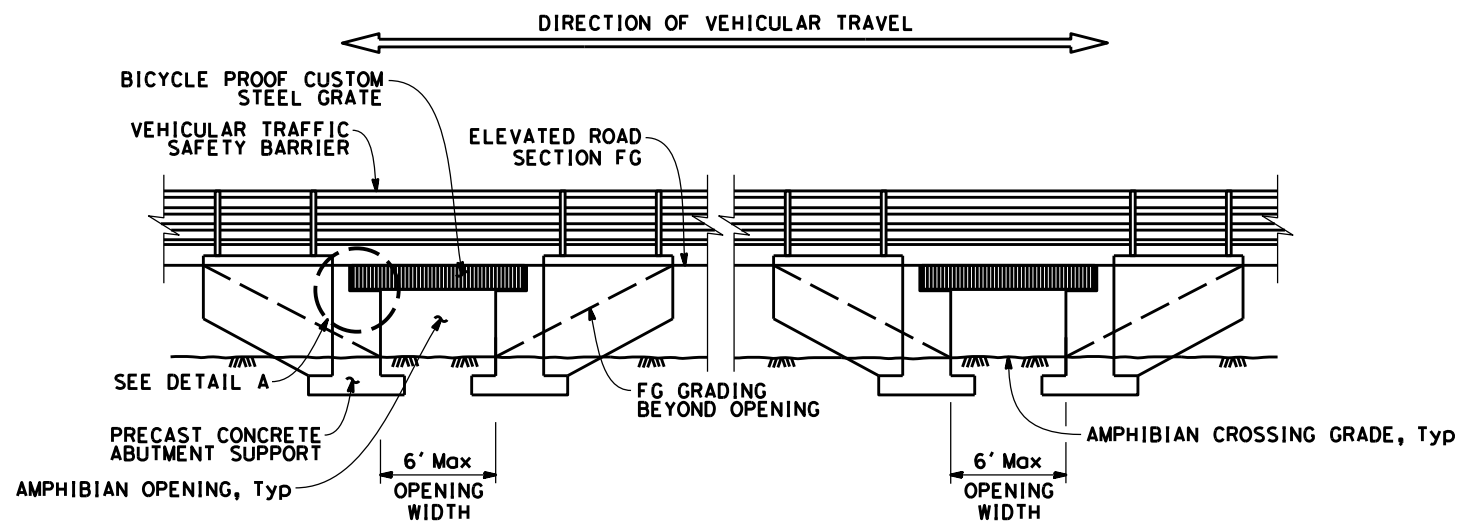
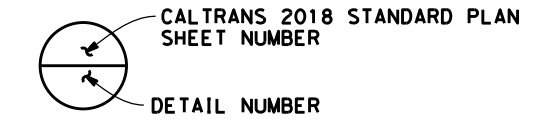

ELEVATION VIEW
SCALE: 1" = 10'

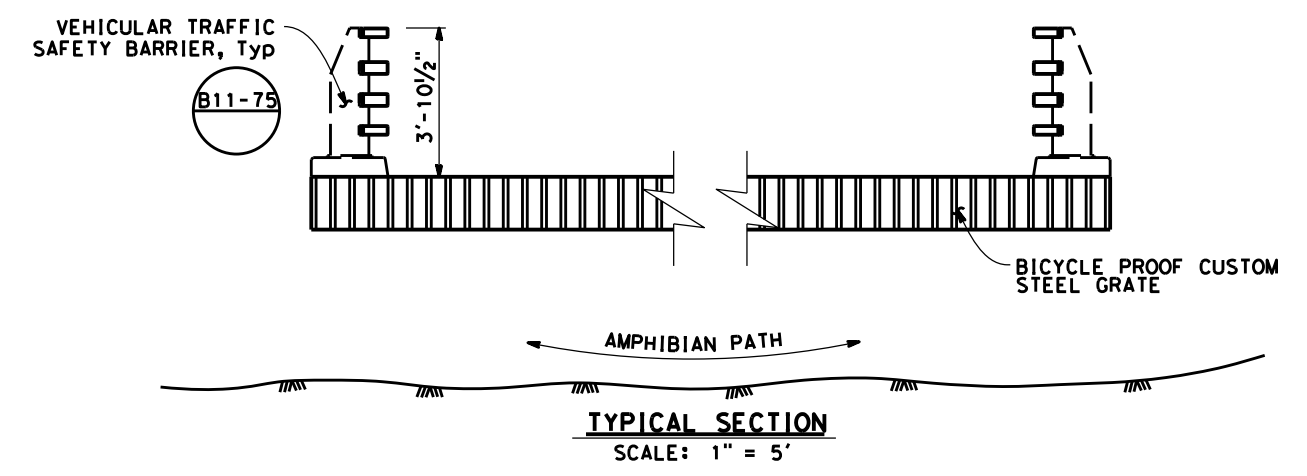

TYPICAL SECTION
SCALE: 1" = 5'

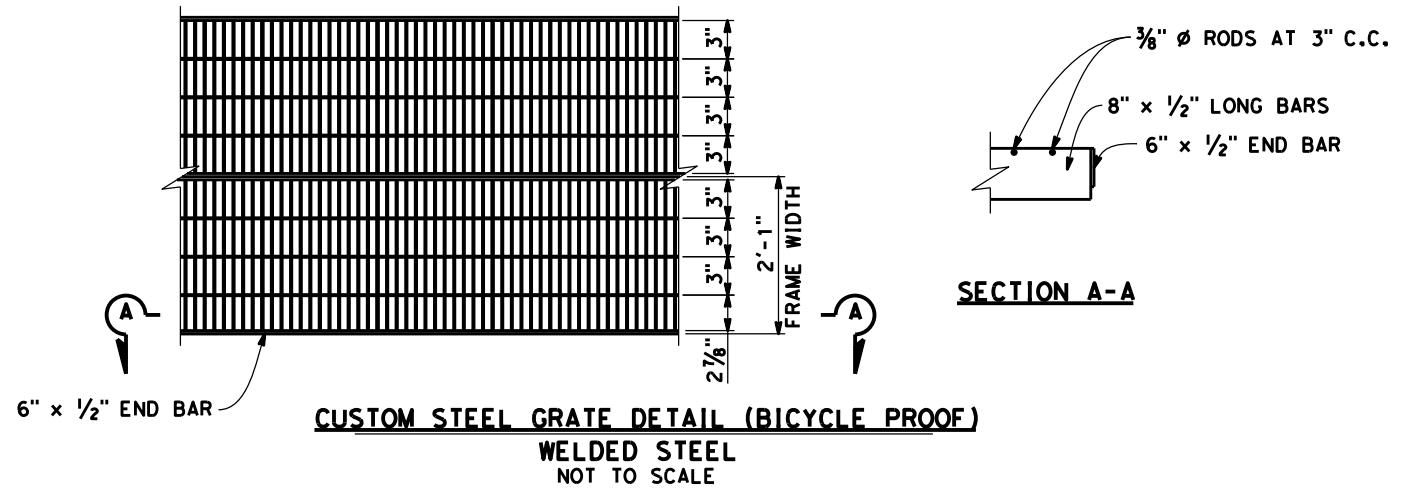
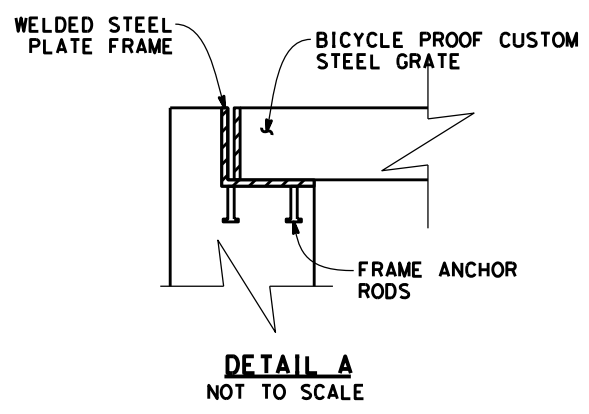

CUSTOM STEEL GRATE DETAIL (BICYCLE PROOF)
WELDED STEEL
NOT TO SCALE

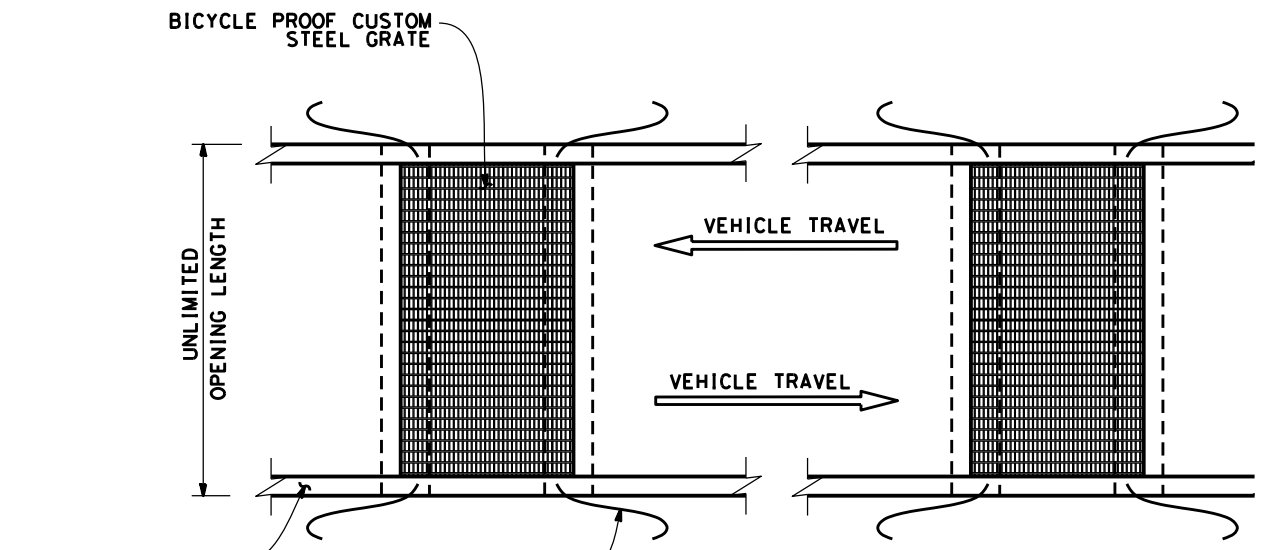

PLAN VIEW
SCALE: 1" = 10'

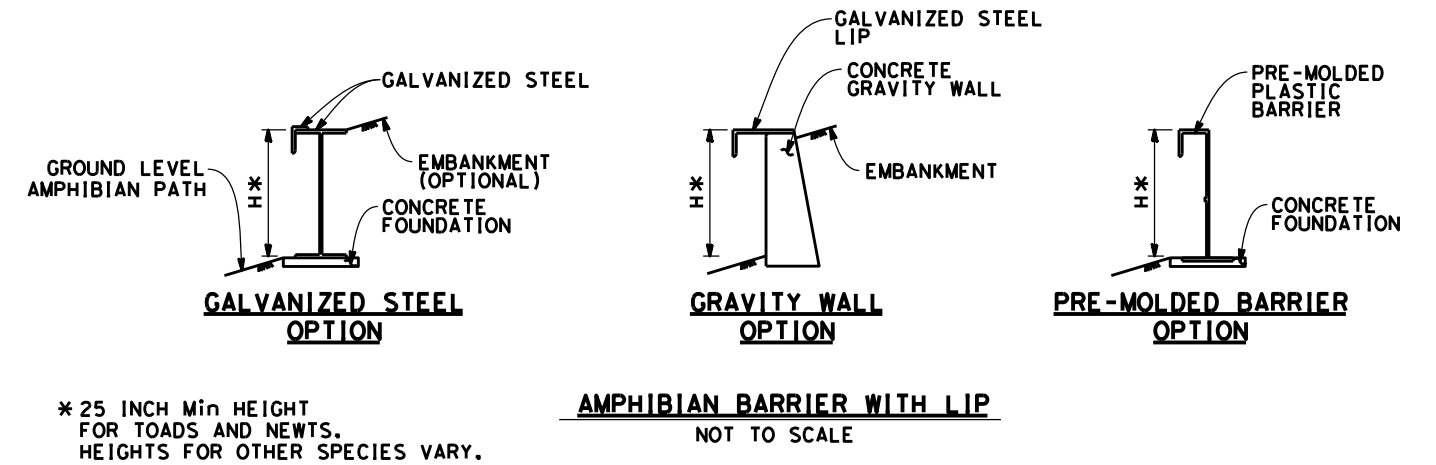

AMPHIBIAN BARRIER WITH LIP
NOT TO SCALE

DESIGN OVERSIGHT _____
SIGN OFF DATE _____

DESIGNED BY	DATE
DRAWN BY	DATE
CHECKED BY	DATE
APPROVED	DATE

PLANNING CONCEPT USGS-AMPHIBIAN CROSSING			
		BRIDGE NO.	UNIT:
PROJECT ENGINEER		SCALE:	PROJECT NUMBER & PHASE:





Nevada Department of Transportation

Kristina L. Swallow, P.E. Director
Ken Chambers, Research Division Chief
(775) 888-7220
kchambers@dot.nv.gov
1263 South Stewart Street
Carson City, Nevada 89712