

State of Nevada
Department of Transportation
Materials Division

METHOD OF TEST FOR DETERMINING THE LIQUID LIMIT OF SOIL

SCOPE

This test method is used to determine the liquid limit of a soil. Liquid limit is defined as the moisture content at which a soil passes from a plastic state to a liquid state.

APPARATUS

1. Porcelain mixing bowl or similar non-absorbent mixing bowl (Figure 4), approximately 115 mm to 150 mm (4.5 in. to 6 in.) in diameter.
2. Spatula or pill knife (Figure 4), having a blade approximately 75 mm to 100 mm (3 in. to 4 in.) in length and 13 mm to 20 mm (½ in. to ¾ in.) in width.
3. Liquid limit device (Figure 4), manual or mechanical.

Manually operated device: A device consisting of a brass dish and carriage, constructed to the plan and dimensions shown in Figure 1. If a manually operated device is used, it shall be noted on the worksheet, [or in the Remarks section of the Agency View](#).

Mechanically operated device: A motorized device equipped to produce the rise and rate of shocks to a brass dish constructed to the plan and dimensions shown in Figure 1.

4. Curved grooving tool, conforming to the critical dimensions shown in Figure 1. The use of a flat grooving tool shall not be permitted in this test procedure.
5. Gage, attached to the grooving tool (Figure 4), shall conform to the critical dimension “d” shown in Figure 1 of this method. If separate, the gage may be a metal bar 10.0 mm ± 0.2 mm (0.394 in. ± 0.008 in.) thick and approximately 50 mm (2 in.) long.
6. Glass beaker (Figure 4), 600 mL or another suitable microwave safe container.
7. Watch glass (Figure 4), approximately 75 mm (3.0 in.) in diameter.

8. Two Balances, one having a 1 g minimum capacity, sensitive to $\pm .01$ g (Figure 4) and the other balance having a 12,000 g capacity, sensitive to 0.1 g.
9. Oven, capable of maintaining a temperature of $110 \pm 5^{\circ}\text{C}$ ($230 \pm 9^{\circ}\text{F}$).
10. Microwave oven.
11. Sieves (Figure 5), woven wire cloth sieves with 2.00 mm (No. 10), 425 μm (No. 40) sieves with square openings, pan and lid.
12. Pulverizing apparatus, a mechanical pulverizing apparatus (MPA) (Figure 6) consisting of a power driven covered muller, a timer and a revolving drum into which the two rubber covered rollers and the soil sample are placed or a metal mortar and rubber-covered pestle (Figure 7).
13. Syringe (Figure 4), reading from 1 to 50 ml.

CALIBRATION OF LIQUID LIMIT DEVICE

1. The manual or mechanical liquid limit device shall be inspected for the following: the pin connecting the cup is not worn sufficiently to permit side play; the screws connecting the cup to the hanger arm are tight; the points of contact on the cup and base are not excessively worn; the lip of the cup is not excessively worn; and a groove has not been worn into the cup through long usage. The grooving tool shall be inspected to determine that the critical dimensions are followed as shown in Figure 1.

Wear is considered excessive when the point of contact on the cup or base exceeds 13 mm ($\frac{1}{2}$ in.) in diameter, or when any point on the rim of the cup is worn to approximately half of the original thickness. Although a slight groove in the center of the cup is noticeable, it is not objectionable. If the groove becomes pronounced before other signs of wear appear, the cup should be considered excessively worn. Excessively worn cups shall be replaced. A base that is excessively worn may be refinished as long as the thickness does not exceed the tolerance shown in Figure 1 by more than -2.5 mm (-0.1 in.), and the distance between the cup at the cam follower and the base is maintained within the tolerances specified in Figure 1.

2. Adjust the height of drop of the cup so that the point on the cup that comes in contact with the base rises to a height of $10.0 \text{ mm} \pm 0.2 \text{ mm}$ ($0.394 \text{ in.} \pm 0.008 \text{ in.}$). See Figure 2 for proper location of the gage relative to the cup during adjustment.

Adjusting the height of the drop is as follows: Place a piece of masking tape across the outside bottom of the cup parallel with the axis of the cup hanger pivot. The edge of the tape away from the cup hanger should bisect the spot on the cup that contacts the base. For new cups, place a piece of carbon paper on the base (or use a marking pen to mark the base where it contacts the cup) and allow

the cup to drop several times to mark the contact spot. Ensure the cup is in contact with the base. Slide the height gage under the cup from the front until the gage contacts the masking tape, see Figure 2. Start the device to verify a slight ringing or clicking sound is heard without the cup rising from the gage. If the masking tape and cup are both contacted, the height of drop is correct. If not, adjust the cup until simultaneous contact is made. Check adjustment by turning the crank at two revolutions per second while holding the gage in position against the tape and cup or turn the automatic L.L. device on. If a slight ringing or clicking sound is heard without the cup rising from the gage, the adjustment is correct. If no ringing is heard or if the cup rises from the gage, readjust the height of the drop. If the cup rocks on the gage during this checking operation, the cam follower pivot is excessively worn. Therefore, the worn parts should be replaced. Always remove the masking tape after completion of the adjustment operation.

SAMPLING

Obtain a representative sample per Test Method Nev. T200.

SAMPLE PREPARATION

1. Obtain a representative sample in accordance with Test Method Nev. T203.

For coarse materials, prepare between a 3,000 g and 6,500 g sample. The sample size shall be sufficient enough to provide a minimum of 85 g oven dried material passing the 425 um (No. 40) sieve. *If a minimum of an 85 g sample of oven dried material passing the 425 um (No. 40) sieve is not obtained, the amount of coarse material processed shall be between 6,000 g and 6,500 g.* Coarse material being defined as 10% or more of the stockpile retained on the 4.75 mm (No. 4) sieve. *Coarse stockpiles will be processed using the Mechanical Pulverizing Apparatus (MPA).*

For fine material, prepare 1,250 g ± 250 g sample. Fine stockpiles will be processed using a mortar and rubber-covered pestle.

Dry the representative sample to a constant weight at a temperature not to exceed 60°C (140°F) and record the “*Total Wt. Processed (g)*” in the appropriate NDOT *Agency View* after drying is complete.

2. The aggregations of soil particles shall then be broken up in the pulverizing apparatus in such a way as to avoid reducing the natural size of individual particles with one of the following procedures:
 - a. Mechanical Pulverizing Apparatus (MPA) – tumbling: When using the MPA, place the two rubber covered rollers into the drum with the entire sample. Attach the lid and make sure the lid is sealed tightly. If a proper seal is not achieved, the replacement of the lid, clamp or drum

may be required. Place the drum on the machines rollers and start the MPA until approximately 420 revolutions (approximately 6 minutes) have been achieved.

NOTE: If the drum has to be rolled at a slower rate so that the drum stays on the rollers, then additional revolutions may be needed. This should be determined during the annual equipment calibration.

- b. Mortar and Pestle: Fill the mortar to no more than three quarters full to allow for the pestle to move around the sample in the mortar. Be careful not to hammer on the sample with the pestle. Move the pestle around the mortar in a grinding and twisting motion so that all the sample is being processed. If the sample contains brittle particles, such as flakes of mica, fragments of seashells, etc., the pulverizing operation shall be done carefully and with just enough pressure to free the finer material that adheres to the coarser particles. Repeat until the entire sample is processed.
3. Place a portion of the tumbled or mortared sample onto the 2.00 mm (No. 10) sieve and the pan, taking care not to overload the sieve and cover with the lid. Shake the material with a side to side and front to back shaking motion for approximately one minute, tapping the bottom of the pan on the counter occasionally. Place the material retained on the 2.00 mm (No. 10) sieve in a pan. Place the minus 2.00 mm (- No. 10) material in a second pan. Repeat this process until all the tumbled or mortared material has been shaken, sieved, and separated over the 2.00 mm (No. 10) Sieve. Once this has been achieved, sieve all the - 2.00 mm (- No. 10) material over the 425 μ m (No. 40) screen. Weigh the material passing the 425 μ m (No. 40) screen. If less than 85 grams of material is obtained, proceed with step a. or b. below.
 - a. If using the MPA process, place the two rollers, followed by all the material retained on the 2.00 mm (No. 10) sieve, back into the drum and reseal the lid. Restart the MPA and let it run an additional 210 revolutions (approximately 3 minutes). Once the MPA is completed, repeat Step #3 for the last time. Once Step #3 is completed for the last time, the material now retained on the 2.00 mm (No. 10) and the 425 μ m (No. 40) sieve shall be discarded.
 - b. If using the Mortar and Pestle process, repeat Step #2b one **more** time with all the material retained on the 2.00 mm (No. 10) sieve and then all the material retained on the 425 μ m (No. 40) sieve until the aggregation of soil particles are sufficiently broken into separate grains without fracturing the aggregate or individual grains. This process of mortaring and sieving shall be repeated until the material is visibly free of clay lumps, clots, and coatings, and until there is no appreciable amount of material passing the 2.00 mm (No. 10) sieve or the 425 μ m (No. 40) sieve. Once that is accomplished, the material now retained on the 2.00 mm (No. 10) and the 425 μ m (No. 40) sieve shall be discarded.

4. If 85 g or more is obtained, proceed with “PROCEDURE – METHOD A (THREE POINT METHOD)”.

If less than 85 g is obtained, the test result shall be documented as “Insufficient Material”. To document “Insufficient Material” a total of 6500 g for coarse material or 1500 g of fine material shall have been processed. It shall be documented under remarks, “Unable to obtain 85 g of material”.

PROCEDURE – METHOD A (THREE POINT METHOD)

1. When referee or dispute testing, the metal mortar and rubber-covered pestle will be used as the pulverizing apparatus. Referee or disputed tests shall be performed using distilled or demineralized water.
2. Use the – 425 μm (– No. 40) material obtained in the “SAMPLE PREPARATION”. Stir the – 425 μm (– No. 40) material until it is blended into a homogenous state. Spoon out a sample weighing 100 g \pm 15 g from the thoroughly mixed portion of the material into the porcelain mixing bowl.

NOTE: If a minimum of 85 g is not obtained from the entire dried sample, [input the weight into the “Wt. of -#40 Obtained \(g\)”](#) and the Agency View will document it as “Insufficient -#40 Material” and no further testing is required. [The “Test Result” field will be a Pass for insufficient material.](#)

3. Weigh and record all four (4) watch glass tare weights to the nearest 0.01 g.
4. Place the 100 \pm 15 g sample in the mixing bowl and thoroughly mix with 15 mL of water by alternately and repeatedly stirring and kneading with a spatula. Tap water may be used for routine testing if comparative tests indicate no differences in results between tap water and distilled or demineralized water. Use sufficient force in the kneading action to allow the moisture to come into contact with as many soil particles as possible. Further additions of water shall be made in increments of 1, 2 or 3 mL. Record the addition of all water increments [in the “Water Added \(mL\)” field in the appropriate NDOT Agency View](#) (this information may be used for comparison test results between testers). Add sufficient water to thoroughly coat and be absorbed into the soil sample uniformly. Each increment of water shall be thoroughly mixed with the soil, as previously described, before another increment is added. **ONCE TESTING BEGINS, NO ADDITIONAL DRY SOIL SHALL BE ADDED TO THE MOISTENED SOIL. THE CUP OF THE LIQUID LIMIT DEVICE SHALL NOT BE USED FOR MIXING SOIL AND WATER.** If too much moisture has been added to the sample, the sample shall either be mixed in the mixing bowl or kneaded until natural evaporation lowers the closure point to an acceptable range.

Some soils are slow to absorb water. It is possible to add increments of water so fast that a false liquid limit value is obtained. This can be avoided if more mixing time is allowed.

5. A sufficient amount of the moistened sample shall be placed in the bottom of the brass cup. Spread the sample with the spatula to where the sample level is trimmed to a depth of 10 mm (0.4 in.) at the point of maximum thickness. **While using the spatula to spread the sample**, use as few strokes as possible taking care to prevent the entrapment of air bubbles within the mass.

Return the excess soil to the mixing dish and cover with a damp rag to retain the moisture in the sample. The soil in the brass cup of the device shall be divided by a stroke of the curved grooving tool along the diameter through the centerline of the brass cup so that a clean sharp groove of the proper dimensions will be formed as shown in Figure 3. To avoid tearing of the sides of the groove or slipping of the soil cake on the cup, use six strokes with a stroke from front to back or back to front counting as one stroke. Start the first stroke from front to back. The depth of the groove should be increased with each stroke and only the last stroke should scrape the bottom of the brass cup.

6. The brass cup containing the sample shall be lifted and dropped, mechanically or manually, at a rate of approximately two revolutions per second until the two sides of the sample come in contact at the bottom of the groove along a distance of about 13 mm (½ in.). The number of shocks required to close this groove distance shall be recorded **in the appropriate NDOT Agency View in the “Blow Count” field**. If using the manual device, **do not hold** the base of the machine with the free hand when turning the crank.

Once the 25 – 35 shock range is achieved, the sample is then hydrated for 30 minutes ± 1 minute in the porcelain mixing bowl under a damp rag. After the sample has been hydrated, add 1 mL of water and mix for 1 minute.

NOTE: If the sample slides on the surface of the cup instead of flowing, add 1 mL more of water to the sample, remix, and retest. If the soil continues to slide on the cup at less than 25 blows, the test is not applicable, and a note **shall** be made in the remarks that the liquid limit could not be determined due to sliding in the brass cup **and the Test Result will be Pass**.

7. Once your initial blow range between the 25 and 35 shock range has been achieved, a slice of soil shall be removed and placed on a pre-weighed watch glass. The slice of soil shall be approximately the width of the spatula, extending across the soil cake perpendicular to the groove and including the portion of the groove in which the soil flowed together. Weigh the watch glass and soil together and record this as the **“Wet + Tare Wt. (g)” field** to the nearest 0.01 g **in the appropriate NDOT Agency View**. After removing the slice of material from the brass cup, the soil remaining in the brass cup shall be transferred back into the porcelain mixing bowl and covered with the damp rag. The brass cup and grooving tool shall then be washed and dried in preparation for the sample in the next shock range. After the 1st shock range is obtained, remove an 8 g representative sample from the porcelain mixing bowl and place under watch glass #4 until Test Method Nev. T211/T212 is ready to be performed.

8. Add 1, 2 or 3 mL of water at a time to the soil remaining in the porcelain mixing bowl until the next shock range is achieved. Thoroughly mix the water into the sample by alternately stirring and kneading with a spatula.
9. Steps # 5, # 6, # 7 and # 8 shall be repeated for at least two additional portions of the sample to which sufficient water has been added to bring the soil to a more fluid condition. The object of this procedure is to obtain samples of such consistency that at least one determination will be made in each of the following shock ranges: 25 – 35, 20 – 30, 15 – 25, and the range between the three determinations is at least 10 shocks between the first and third shock range. If there are not 10 shocks between the first and third shock range, the test is considered invalid and another test shall be performed.
10. Dry all **three** samples, **plus the sample you will obtain from T211K**, using one of the methods in Test Method Nev. T112 or by the following microwave oven procedure: Place a 600 mL glass beaker or other suitable container filled with approximately 300 mL of water (maintain water level during drying) into the microwave oven to prevent over heating during the drying process. Place all four of the watch glasses and soil into the microwave oven. Dry the sample for 5 minutes, then change the water with fresh cool water.

Continue drying at 2 minute intervals until a constant weight is achieved. Drying times may be adjusted based on type and size of microwave oven. Weigh and record the dried and cool samples to the nearest 0.01 g as “Dry + Tare Wt. (g)” field in the appropriate NDOT [Agency View](#).

11. The “**Moisture Content (%)**” will be calculated to the nearest 0.1 percent in the appropriate NDOT [Agency View](#).

REFEREE OR DISPUTE TESTING

Method A shall be used in performing referee or dispute tests. The results of the liquid limit are influenced by the following: the time required to perform the test, the moisture content at which the test begins, and the addition of dry soil to the hydrated sample (**NOT ALLOWED**).

In performing the liquid limit test for referee or dispute purposes, the following time schedule shall replace the time schedule used in “Method A”:

1. Mixing of soils with water: 5 to 10 minutes, the longer period being used for the more plastic soils.
2. Placing in the brass cup and testing: 3 minutes.
3. Adding water and remixing: 3 minutes.

No test requiring more than 35 blows or fewer than 15 blows shall be recorded.

PROCEDURE – METHOD B (*Single point method for the Materials Division Lab only*)

1. The material for the liquid limit test is to be obtained per “SAMPLE PREPARATION”.
2. A sample weighing about 50 g shall be taken from the thoroughly mixed portion of the material passing the 425 μm (No. 40) sieve that has been obtained in accordance with this test method.

NOTE: If 50 g are not obtained, the sample is to be reported as insufficient material and no further testing is required.

3. Use the test procedure from “Method A” except that the initial amount of water to be added will be 8 to 15 mL, and the moisture sample taken shall be only for the one point.
4. Groove closures between 15 and 35 blows may be accepted if variations of ± 5 percent of the true liquid limit are tolerable.
5. Groove closures between 5 and 15 blows may be accepted when testing sand.

CALCULATION

The water content of the soil shall be expressed as the moisture content in percentage of the mass of the oven dried soil and shall be calculated as follows:

$$(\text{Wet} + \text{Tare Weight (g)}) - (\text{Dry} + \text{Tare Weight (g)}) = W$$

$$(\text{Dry} + \text{Tare Weight (g)}) - (\text{Tare Weight (g)}) = D$$

$$(W/D) \times 100 = M$$

W = Weight of water

D = Dry weight of soil

M = Moisture Content (%)

The Moisture Content (%) will be calculated to the nearest 0.1 percent and reported in the appropriate NDOT Agency View.

PREPARATION OF FLOW CURVE

A Flow Curve representing the relationship between Percent Moisture and corresponding No. of Blows shall be plotted on the graph provided in the appropriate NDOT Agency View. The Percent Moisture shall run across the bottom of the graph (x-axis) and the No. of Blows shall be on the left of the graph (y-axis). The flow curve shall be a straight line drawn as nearly as possible through the three plotted points. The difference between the two lines that intersect the 25 shock ordinate shall not be more than 0.3 percent moisture.

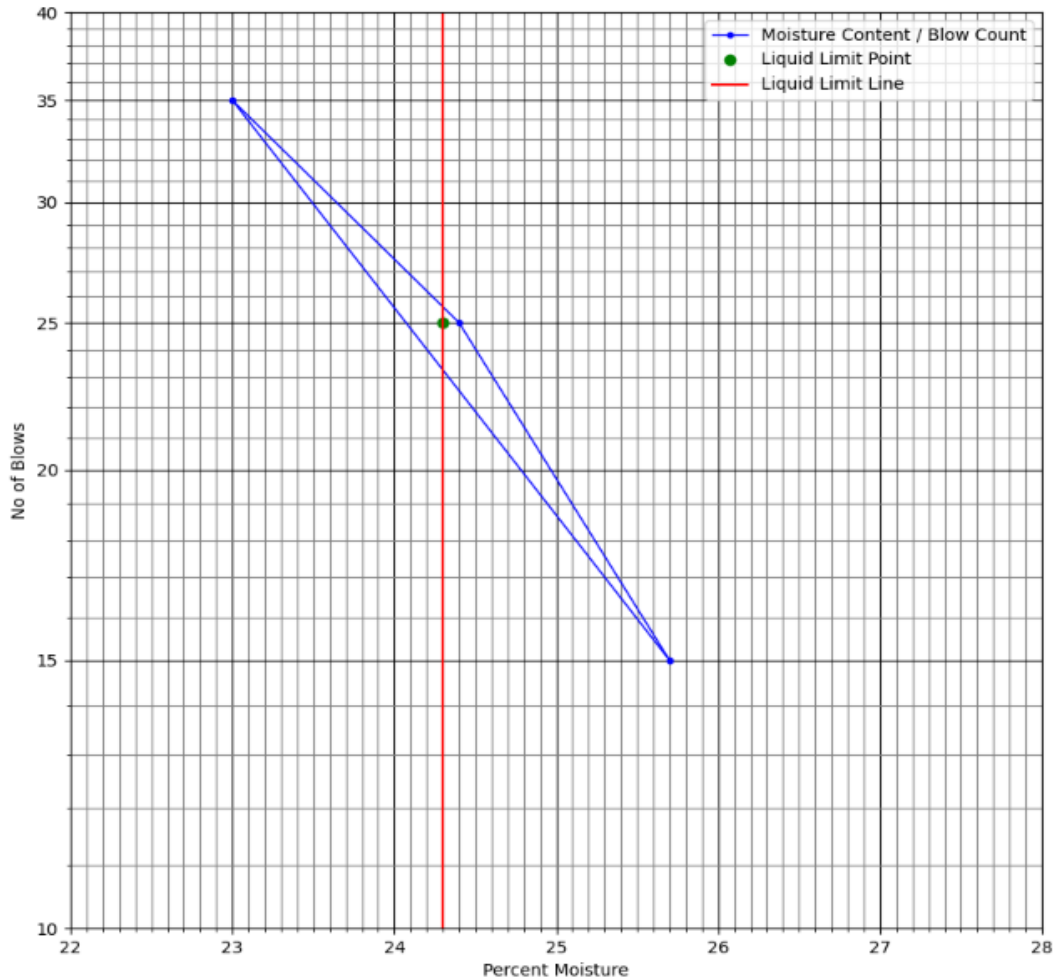

If there is more than 0.3% on the 25 shock ordinate, **DO NOT CHECK THE “At 25 shocks, 0.3% or less?” BOX IN THE AGENCY VIEW.** The Agency View will generate an error in red stating “Test invalid, due to more than 0.3% on the 25 line.” Test must be re-run and submitted.” The test is considered invalid, and another test shall be performed.

When a triangle is formed, calculate the average moisture content of the two lines that intersect the 25 shock ordinate to obtain the **Liquid Limit** value. If the difference is outside of the 0.3 percent range, the test is considered invalid and another test shall be performed.

LIQUID LIMIT

The **Percent Moisture** corresponding to the intersection of the flow curve with the 25 shock ordinate shall be taken as the Liquid Limit of the soil. **Input** the “Liquid Limit” to the nearest 0.1 **in the appropriate NDOT Agency View**. This Liquid Limit value will be utilized for **the** calculation of the “**Plasticity Index**” in Test Method Nev. T211/212.

If unable to obtain a Liquid Limit after running the test in its entirety as described, **check the box “Non-Plastic”** on the appropriate NDOT Agency View and NP will be reported in the “**Reported Plasticity Index**”. Report the “**Test Result**” value as Pass. The Agency View will have an error populate in red stating “**Test invalid, due to more than 0.3% on the 25 line, for “Non-Plastic” this error can be ignored.**”

REPORT

Report the “Liquid Limit” to the 0.1 and the “**Reported Liquid Limit**” **will be reported to the** nearest whole number **on the appropriate NDOT Agency View**.

PRECISION STATEMENT

This precision statement only applies to soils having a liquid limit range from 21 to 67.

1. Repeatability (single operator): Two results obtained by the same operator on the same sample in the same laboratory using the same equipment and on different days, should be considered suspect if they differ by more than 7 percent of their average.
2. Reproducibility (multi-laboratory): Two results obtained by different operators in different laboratories should be considered suspect if they differ from each other by more than 13 percent of their average.

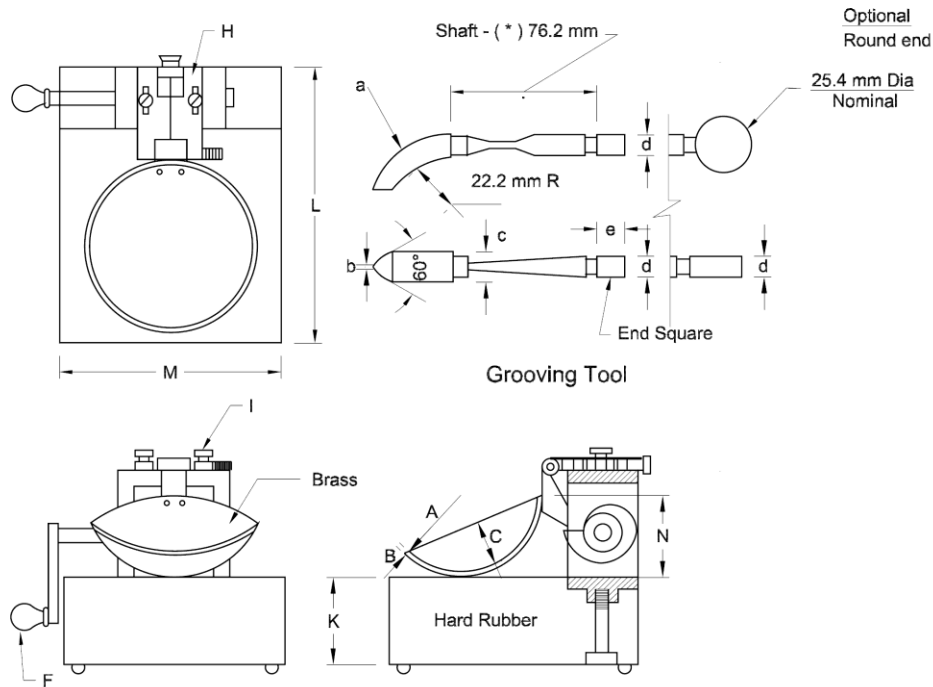

Dimension	Liquid Limit Device							Grooving Tool				
	Cup Assembly				Base			Curved End			Gage	
Description	A	B	C	N	K	L	M	a	b	c	d	*c
Metric, mm	54	2.0	27	47	50	150	125	10.0	2.0	13.5	10.0	15.9
Tolerance, mm	2	0.1	0	1.5	5	5	5	0.1	0.1	0.1	0.2	—

Note: Plate "H" may be designed for using (1) one securing screw (I).
An additional wear tolerance of 0.1 mm shall be allowed for dimension "b" for used grooving tools.
Feet for base shall be of resilient material.
(*) Nominal dimensions.
All tolerances specified are plus or minus (\pm) except as noted above.

Figure 1—Manual Liquid Limit Device

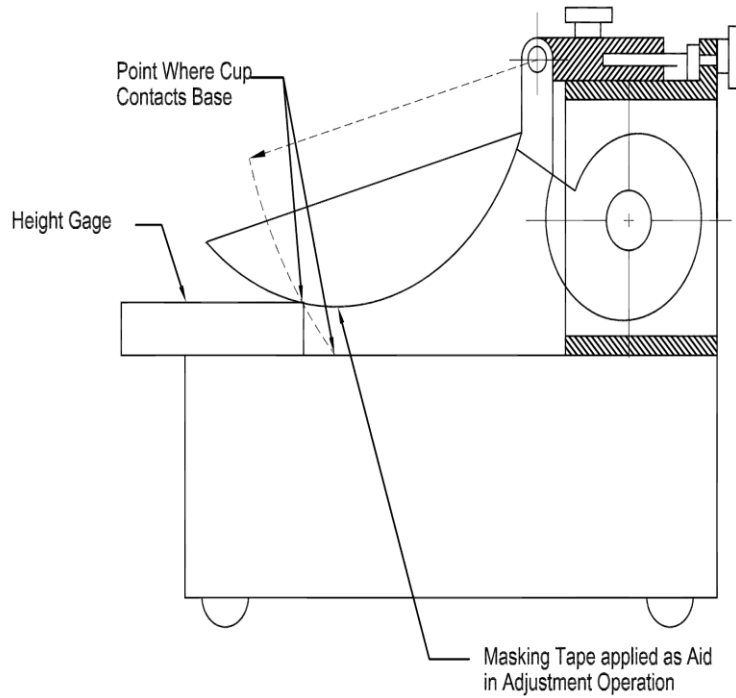

Figure 2—Calibration for Height of Drop

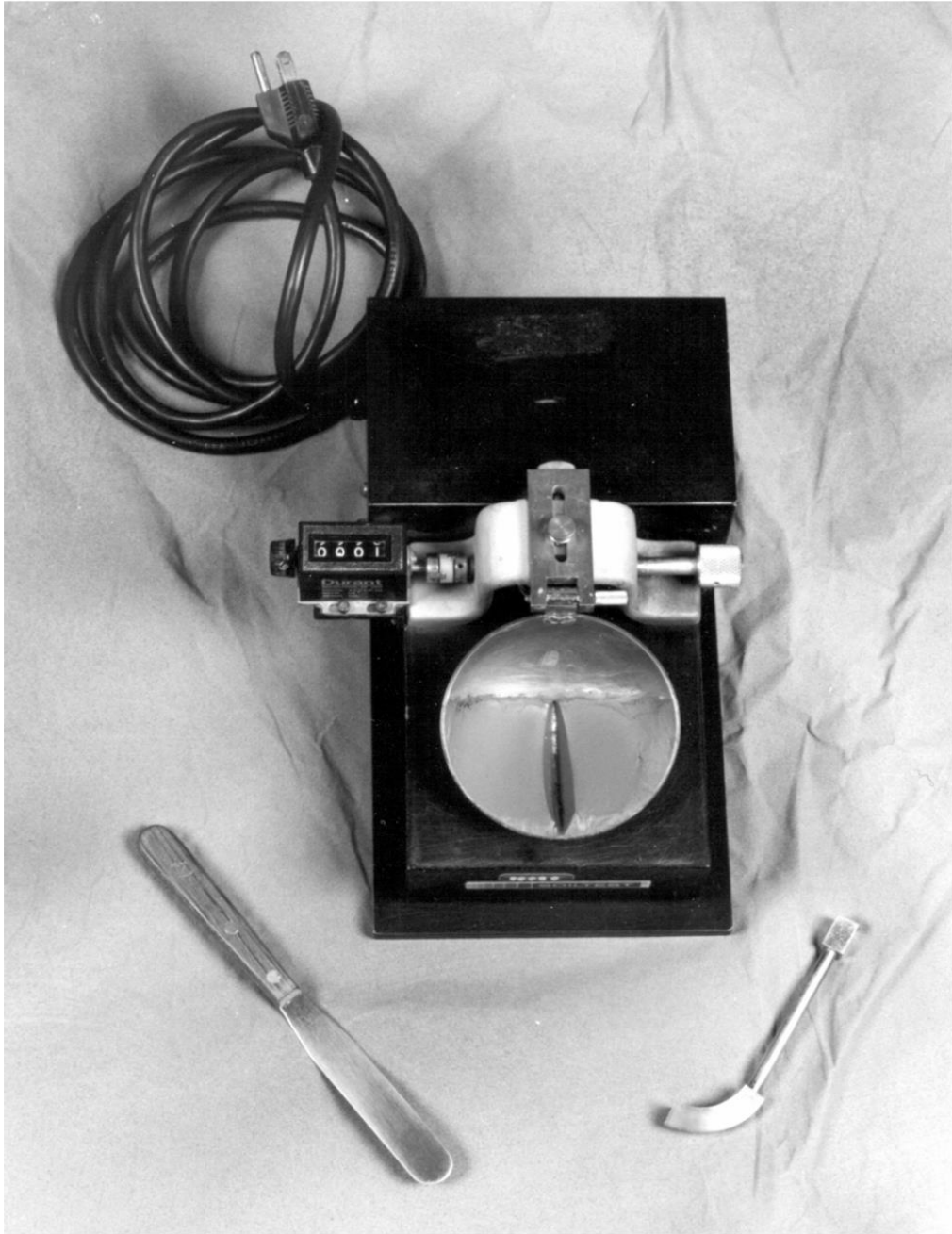

Figure 3—Liquid Limit Device with Soil Sample in Place

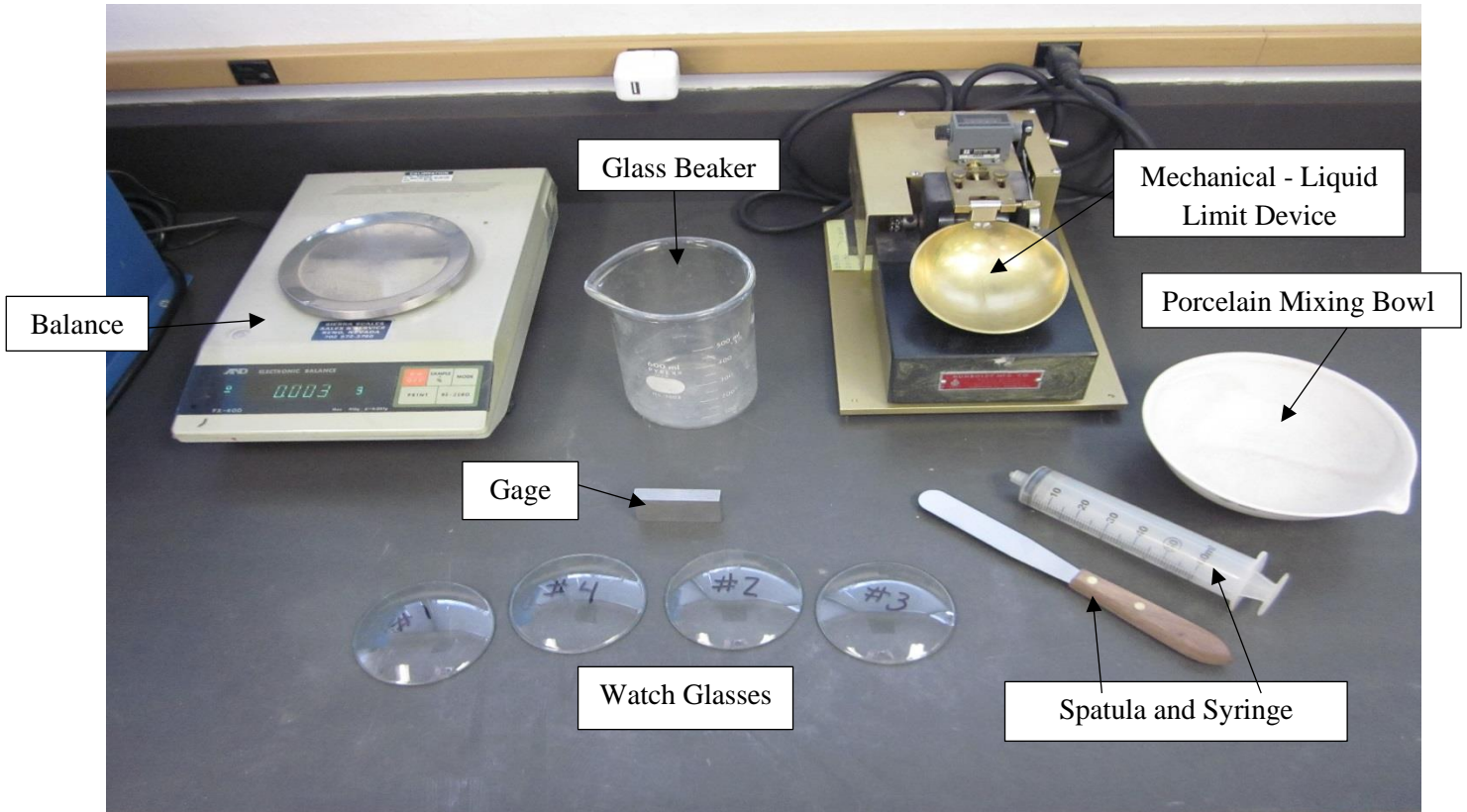

Figure 4



Figure 5
Stack of Sieves



Figure 6
MPA with Revolving Drum



Figure 7
Metal Mortar and Rubber-Covered Pestle