

State of Nevada  
Department of Transportation  
Materials Division

**METHOD OF TEST FOR DETERMINING THE LIQUID LIMIT OF SOIL**

**SCOPE**

The liquid limit of a soil is that water content, as determined in accordance with the following procedure, at which the soil passes from a plastic state to a liquid state.

**APPARATUS**

1. Porcelain mixing bowl or similar non-absorbent mixing bowl (Figure 4), approximately 115 mm to 150 mm (4.5 in. to 6 in.) in diameter.
2. Spatula or pill knife (Figure 4), having a blade approximately 75 mm to 100 mm (3 in. to 4 in.) in length and 13 mm to 20 mm ( $\frac{1}{2}$  in. to  $\frac{3}{4}$  in.) in width.
3. Liquid limit device, manual or mechanical.

Manually operated device: a device consisting of a brass dish and carriage, constructed to the plan and dimensions shown in Figure 1. If a manually operated device is used, it shall be noted on NDOT form 040-014 the worksheet.

Mechanically operated device: a motorized device equipped to produce the rise and rate of shocks to a brass dish, constructed to the plan and dimensions shown in Figure 1.

4. Curved grooving tool, conforming to the critical dimensions shown in Figure 1. The use of a flat grooving tool shall not be permitted in this test procedure.
5. Gage, attached to the grooving tool (Figure 4), shall conform to the critical dimension “d” shown in Figure 1 of this method. If separate, the gage may be a metal bar 10.0 mm  $\pm$  0.2 mm (0.394 in.  $\pm$  0.008 in.) thick and approximately 50 mm (2 in.) long.
6. Glass beaker (Figure 4), 600 mL or other suitable microwave safe container.
7. Watch glass (Figure 4), approximately 75 mm (3.0 in.) in diameter.

8. Two Balances, one having 500 g minimum capacity, accurate to  $\pm .01$  g (Figure 4) and the other balance having a 12,000 g capacity and sensitive to 0.1 g.
9. Oven, capable of maintaining a temperature of  $110 \pm 5^\circ$  C ( $230 \pm 9^\circ$ F).
10. Microwave Oven
11. Sieves (Figure 5), woven wire cloth sieves with 2.00 mm (No. 10), 425  $\mu$ m (No. 40) sieves with square openings, pan and lid.
12. Pulverizing apparatus, a mechanical pulverizing apparatus (MPA) (Figure 6) consisting of a power driven covered muller, a timer and a revolving drum into which the two rubber covered rollers and the soil sample are placed or a metal mortar and rubber-covered pestle (Figure 7).
13. Syringe (Figure 4), reading from 1 to 50 ml.

#### **CALIBRATION OF LIQUID LIMIT DEVICE**

1. The manual or mechanical liquid limit device shall be inspected for the following: the pin connecting the cup is not worn sufficiently to permit side play; the screws connecting the cup to the hanger arm are tight; the points of contact on the cup and base are not excessively worn; the lip of the cup is not excessively worn; and a groove has not been worn in the cup through long usage. The grooving tool shall be inspected to determine that the critical dimensions are followed as shown in Figure 1.

Wear is considered excessive when the point of contact on the cup or base exceeds 13 mm ( $\frac{1}{2}$  in.) in diameter, or when any point on the rim of the cup is worn to approximately half of the original thickness. Although a slight groove in the center of the cup is noticeable, it is not objectionable. If the groove becomes pronounced before other signs of wear appear, the cup should be considered excessively worn. Excessively worn cups shall be replaced. A base that is excessively worn may be refinished as long as the thickness does not exceed the tolerance shown in Figure 1 by more than  $-2.5$  mm ( $-0.1$  in.) and the distance between the cup at the cam follower and the base is maintained within the tolerances specified in Figure 1.

2. Adjust the height of drop of the cup so that the point on the cup that comes in contact with the base rises to a height of  $10.0$  mm  $\pm 0.2$  mm ( $0.394$  in.  $\pm 0.008$  in.). See Figure 2 for proper location of the gage relative to the cup during adjustment.

Adjusting the height of the drop is as follows: Place a piece of masking tape across the outside bottom of the cup parallel with the axis of the cup hanger pivot. The edge of the tape away from the cup hanger should bisect the spot on the cup that contacts the base. For new cups, place a piece of carbon paper on the base (or use a marking pen to mark the base where it contacts the cup) and allow

the cup to drop several times to mark the contact spot. Attach the cup to the device and turn the crank until the cup is raised to its maximum height. Slide the height gage under the cup from the front, and observe whether the gage contacts the cup or the tape, see Figure 2. If the tape and cup are both contacted, the height of drop is correct. If not, adjust the cup until simultaneous contact is made. Check adjustment by turning the crank at two revolutions per second while holding the gage in position against the tape and cup. If a slight ringing or clicking sound is heard without the cup rising from the gage, the adjustment is correct. If no ringing is heard or if the cup rises from the gage, readjust the height of the drop. If the cup rocks on the gage during this checking operation, the cam follower pivot is excessively worn and the worn parts should be replaced. Always remove the tape after completion of the adjustment operation.

## **SAMPLE PREPARATION**

1. Obtain a representative sample per Test Method Nev. T200.
2. Obtain a representative sample in accordance with Test Method Nev. T203. Coarse material shall be  $6250 \text{ g} \pm 250 \text{ g}$ . Coarse material being defined as 10% or more of the stockpile retained on the 4.75 mm (No. 4) sieve. Fine material shall be  $1250 \text{ g} \pm 250 \text{ g}$ . Dry the representative sample at a temperature not to exceed  $60^{\circ}\text{C}$  ( $140^{\circ}\text{F}$ ) and record the dry weight under remarks on NDOT form 040–014 after drying is complete.

Coarse stockpiles will be processed using the Mechanical Pulverizing Apparatus (MPA).

Fine stockpiles will be processed using a mortar and rubber-covered pestle.

3. The aggregations of soil particles shall then be broken up in the pulverizing apparatus in such a way as to avoid reducing the natural size of individual particles with one of the following procedures:
  - a. Mechanical Pulverizing Apparatus (MPA) – tumbling: When using the MPA, place the two rubber covered rollers into the drum with the entire sample. Attach the lid and make sure the lid is sealed tightly. If a proper seal is not achieved the replacement of the lid, clamp or drum may be required. Place the drum on the machines rollers and start the MPA until approximately 420 revolutions (approximately 6 minutes) have been achieved.

NOTE: If the drum has to be rolled at a slower rate so that the drum stays on the rollers then additional revolutions may be needed – this should be determined during the annual equipment calibration.



## PROCEDURE – METHOD A (THREE POINT METHOD)

1. When referee or dispute testing, the metal mortar and rubber-covered pestle will be used as the pulverizing apparatus. Referee or disputed tests shall be performed using distilled or demineralized water.
2. Use the  $-425\ \mu\text{m}$  ( $-$  No. 40) material obtained in the "SAMPLE PREPARATION". Stir the  $-425\ \mu\text{m}$  ( $-$  No. 40) material until it is blended into a homogenous state. Spoon out a sample weighing  $100\ \text{g} \pm 15\ \text{g}$  from the thoroughly mixed portion of the material into the porcelain mixing bowl. NOTE: If a minimum of 85 g are not obtained from the entire dried sample, the sample is to be reported as insufficient material on NDOT form 040-014 and no further testing is required.
3. Weigh and record all four (4) watch glass tare weights to the nearest 0.01 g, on NDOT form 040-014.
4. Place the  $100 \pm 15\ \text{g}$  sample in the mixing bowl and thoroughly mix with 15 mL of water by alternately and repeatedly stirring and kneading with a spatula. Tap water may be used for routine testing if comparative tests indicate no differences in results between tap water and distilled or demineralized water. Use sufficient force in the kneading action to allow the moisture to come into contact with as many soil particles as possible. Further additions of water shall be made in increments of 1, 2 or 3 mL. Record the addition of all water increments on NDOT form 040-014 (this information may be used for comparison test results between testers). Add sufficient water to thoroughly coat and be absorbed into the soil sample uniformly. Each increment of water shall be thoroughly mixed with the soil, as previously described, before another increment is added. Once testing has begun, no additional dry soil shall be added to the moistened soil. The cup of the liquid limit device shall not be used for mixing soil and water. If too much moisture has been added to the sample, the sample shall either be mixed in the mixing bowl or kneaded until natural evaporation lowers the closure point to an acceptable range.

Some soils are slow to absorb water. It is possible to add increments of water so fast that a false liquid limit value is obtained. This can be avoided if more mixing time is allowed. Once the 25 – 35 shock range is achieved, the sample is then hydrated for 30 minutes  $\pm 1$  minute in the porcelain mixing bowl under a damp rag. After the sample has been hydrated, add 1 mL of water and mix for 1 minute.

5. A sufficient amount of the hydrated sample shall be placed in the bottom of the brass cup. Spread the sample with the spatula to where the sample level is trimmed to a depth of 10 mm (0.4 in.) at the point of maximum thickness. As few strokes as possible with the spatula shall be used, and care will be taken to prevent the entrapment of air bubbles within the mass.

Return the excess soil to the mixing dish and cover with a damp rag to retain the moisture in the sample. The soil in the brass cup of the device shall be divided by a stroke of the curved grooving tool along the diameter through the centerline of the brass cup so that a clean sharp groove of the proper dimensions will be formed as shown in Figure 3. To avoid tearing of the sides of the groove or slipping of the soil cake on the cup, use up to six strokes, with a stroke from front to back or back to

front counting as one stroke. Start the first stroke from front to back. The depth of the groove should be increased with each stroke and only the last stroke should scrape the bottom of the brass cup.

6. The brass cup containing the sample shall be lifted and dropped, mechanically or manually, at a rate of approximately two revolutions per second until the two sides of the sample come in contact at the bottom of the groove along a distance of about 13 mm (½ in.). The number of shocks required to close this groove distance shall be recorded on NDOT form 040-014 under on “No. of Blows”. If using the manual device, do not hold the base of the machine with the free hand, when turning the crank.

NOTE: If the sample slides on the surface of the cup instead of flowing, add 1 mL more of water to the sample, remix and retest. If the soil continues to slide on the cup at less than 25 blows, the test is not applicable and a note should be made in the remarks that the liquid limit could not be determined due to sliding in the brass cup and “N/A” should be written on NDOT form 040-014 under “L.L.”.

7. Once your initial blow range between the 25 and 35 shock range has been achieved, a slice of soil approximately the width of the spatula, extending across the soil cake perpendicular to the groove and including that portion of the groove in which the soil flowed together, shall be removed and placed on a pre-weighed watch glass. Weigh the watch glass and soil together and record this as the “Wet Weight” to the nearest 0.01 g on NDOT form 040-014. After removing the slice of material from the brass cup, the soil remaining in the brass cup shall be transferred back into the porcelain mixing bowl and covered with the damp rag. The brass cup and grooving tool shall then be washed and dried in preparation for the sample in the next shock range. After the 1<sup>st</sup> shock range is obtained remove an 8 g representative sample from the porcelain mixing bowl and place under watch glass #4 upside down until Test Method Nev. T211/T212 is ready to be performed.
8. Add 1, 2 or 3 mL of water at a time to the soil remaining in the porcelain mixing bowl until the next shock range is achieved. Thoroughly mix the water into the sample by alternately stirring and kneading with a spatula.
9. Steps # 5, # 6, # 7 and # 8 shall be repeated for at least two additional portions of the sample to which sufficient water has been added to bring the soil to a more fluid condition. The object of this procedure is to obtain samples of such consistency that at least one determination will be made in each of the following shock ranges: 25 – 35, 20 – 30, 15 – 25, and the range between the three determinations is at least 10 shocks between the first and third shock range. If there are not 10 shocks between the first and third shock range the test is considered invalid and another test shall be ran.
10. Dry all four of the samples using one of the methods in Test Method Nev. T112 or by the following microwave oven procedure: Place a 600 mL glass beaker or other suitable container filled with approximately 300 mL of water (maintain water level during drying) into the microwave oven to

prevent over heating during the drying process. Place all four of the watch glasses and soil into the microwave oven. Dry the sample for 5 minutes and change the water with fresh cool water.

Continue drying at 2 minute intervals until a constant weight is achieved. Drying times may be adjusted based on type and size of microwave oven. Weigh and record the dried and cool samples to the nearest 0.01 g as “Dry Weight” on NDOT form 040–014.

11. Report the “% of Moisture” to the nearest 0.1 percent on NDOT form 040–014.

### **REFEREE OR DISPUTE TESTING**

Method A shall be used in making referee or dispute tests. The results of the liquid limit are influenced by: the time required to perform the test; the moisture content at which the test is begun; and the addition of dry soil to the hydrated sample (not allowed).

In making the liquid limit test for referee or dispute purposes, the following time schedule shall replace the time schedule used in “Method A” be used:

1. Mixing of soils with water: 5 to 10 minutes, the longer period being used for the more plastic soils.
2. Placing in the brass cup and testing: 3 minutes.
3. Adding water and remixing: 3 minutes.

No test requiring more than 35 blows or fewer than 15 blows shall be recorded.

### **PROCEDURE – METHOD B** (*Single point method for the Materials Division Lab only*)

1. The material for the liquid limit test is to be obtained per “SAMPLE PREPARATION”.
2. A sample weighing about 50 g shall be taken from the thoroughly mixed portion of the material passing the 425  $\mu\text{m}$  (No. 40) sieve that has been obtained in accordance with this test method.

NOTE: If 50 g are not obtained, the sample is to be reported as insufficient material and no further testing is required.

3. Use the test procedure from “Method A” except that the initial amount of water to be added will be 8 to 15 mL and the moisture sample taken shall be only for the one point.
4. Groove closures between 15 and 35 blows may be accepted if variations of  $\pm 5$  percent of the true liquid limit are tolerable.
5. Groove closures between 5 and 15 blows may be accepted when testing sand.

## **CALCULATION**

The water content of the soil shall be expressed as the moisture content in percentage of the mass of the oven dried soil and shall be calculated as follows:

$$\text{Percentage of Moisture} = \frac{\text{mass of water}}{\text{mass of oven dried soil}} \times 100$$

Calculate the percentage of moisture to the nearest 0.1 percent on NDOT form 040–014.

## **PREPARATION OF FLOW CURVE**

A Flow Curve representing the relations between moisture content and corresponding number of shocks shall be plotted on the graph provided on form NDOT 040–014. The % of moisture shall run across the bottom of the graph and the shocks shall be on the left of the graph. The flow curve shall be a straight line drawn as nearly as possible through the three plotted points. A computer method of best fit straight line regression analysis may be used to determine the liquid limit. If the three points do not form a straight line, connect the points with three lines, forming a triangle. The difference between the two lines that intersect with the 25 shock ordinate shall not be more than 0.3 percent moisture. If this criterion is not met, the test is considered invalid and another test shall be ran.

When a triangle is formed, take the difference between the two lines that intersect the 25 blow line and average that. Then take the averaged difference and add or subtract to a line dissecting the 25 blow line and this is your LL value. If the difference is outside of the 0.3 percent range, the test is invalid and another test shall be ran.

## **LIQUID LIMIT**

The moisture content corresponding to the intersection of the flow curve with the 25 shock ordinate shall be taken as the liquid limit of the soil. Calculate the liquid limit to the nearest 0.1. This liquid limit value will be utilized for calculation of the plasticity index in Test Method Nev. T211/212. If unable to obtain a liquid limit after running the test in its entirety as described, NA will be recorded under LL and NP recorded under PL.

## **REPORT**

Report the liquid limit to the nearest whole number on NDOT form 040–010. Report the liquid limit on NDOT form 040–014 to the 0.1.



**PRECISION STATEMENT**

This precision statement only applies to soils having a liquid limit range from 21 to 67.

1. Repeatability (single operator): Two results obtained by the same operator on the same sample in the same laboratory using the same equipment and on different days, should be considered suspect if they differ by more than 7 percent of their average.
2. Reproducibility (multi-laboratory): Two results obtained by different operators in different laboratories should be considered suspect if they differ from each other by more than 13 percent of their average.

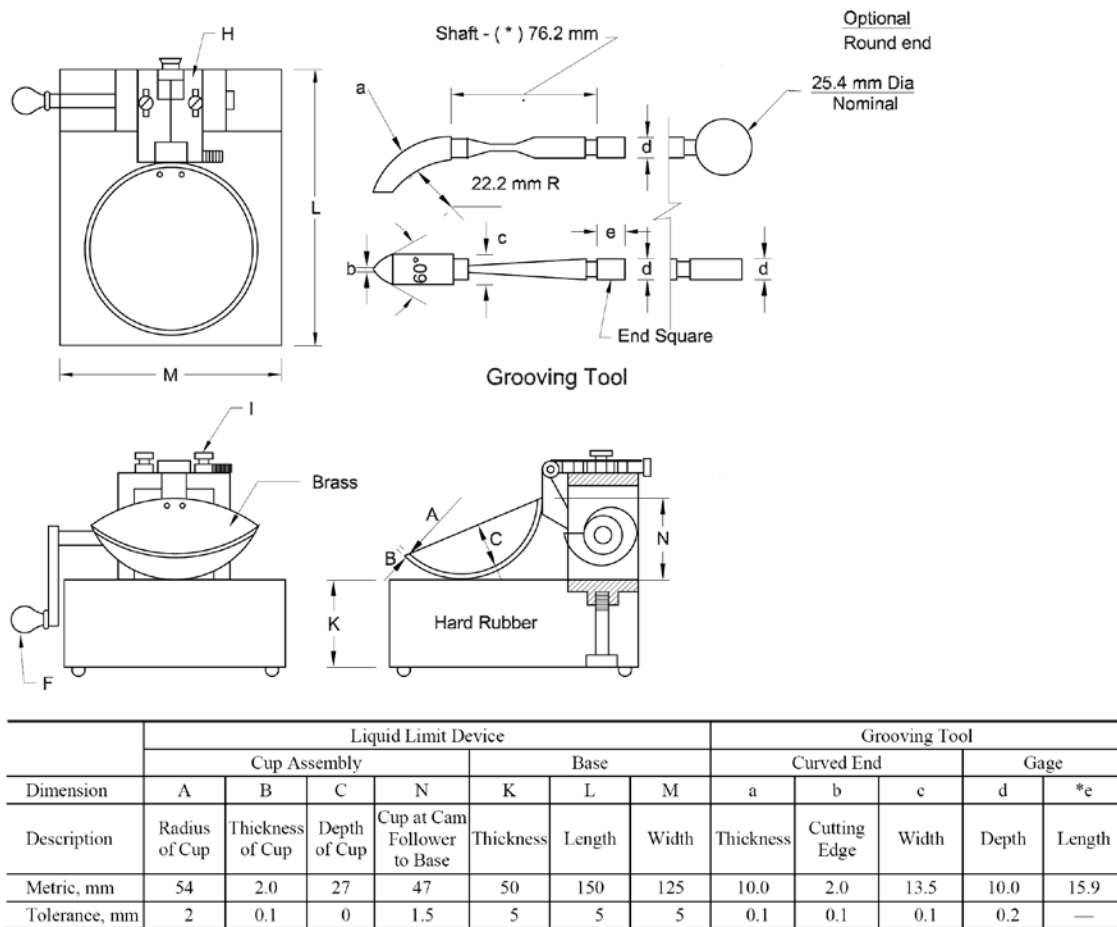

Note: Plate "H" may be designed for using (1) one securing screw (I).  
An additional wear tolerance of 0.1 mm shall be allowed for dimension "b" for used grooving tools.  
Feet for base shall be of resilient material.  
(\* ) Nominal dimensions.  
All tolerances specified are plus or minus (±) except as noted above.

**Figure 1**—Manual Liquid Limit Device

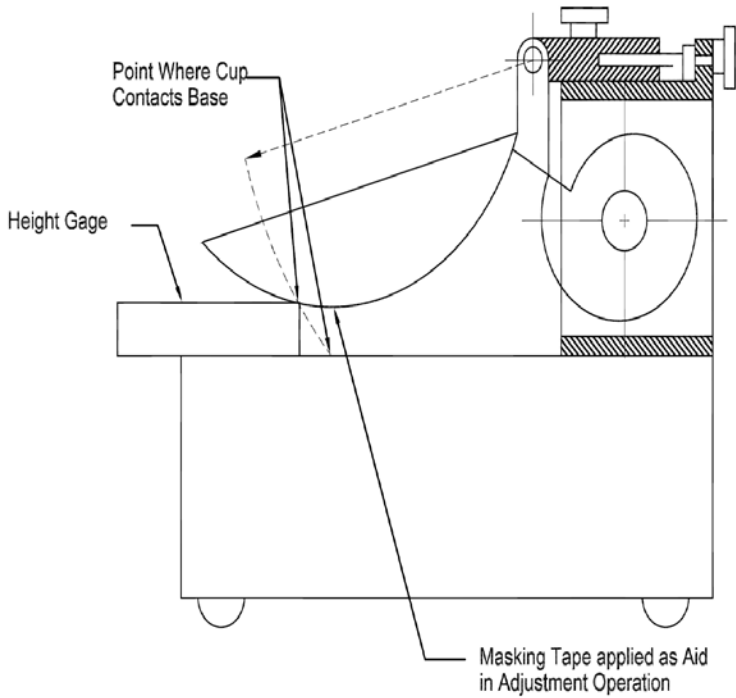

**Figure 2**—Calibration for Height of Drop

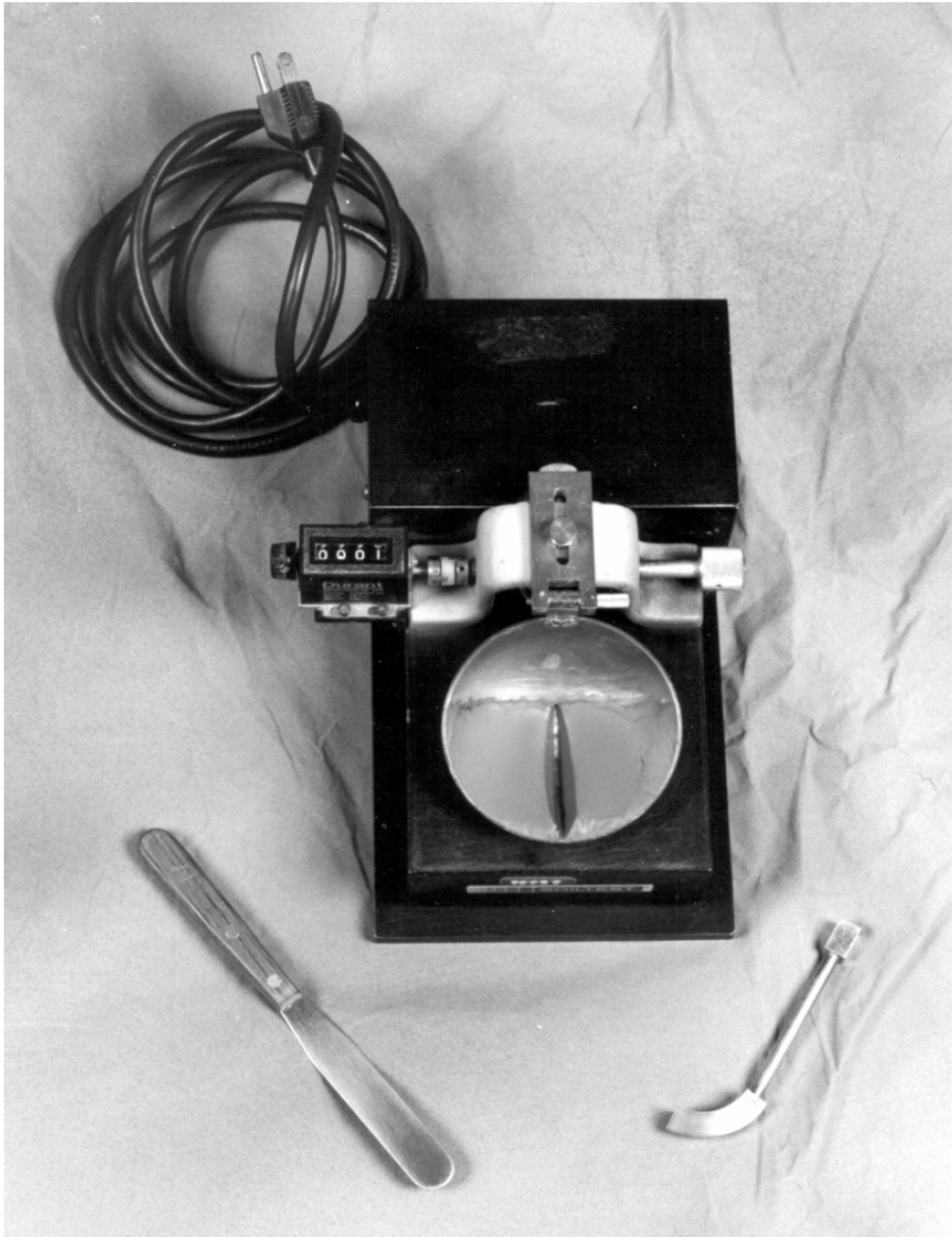

**Figure 3**—Liquid Limit Device with Soil Sample in Place

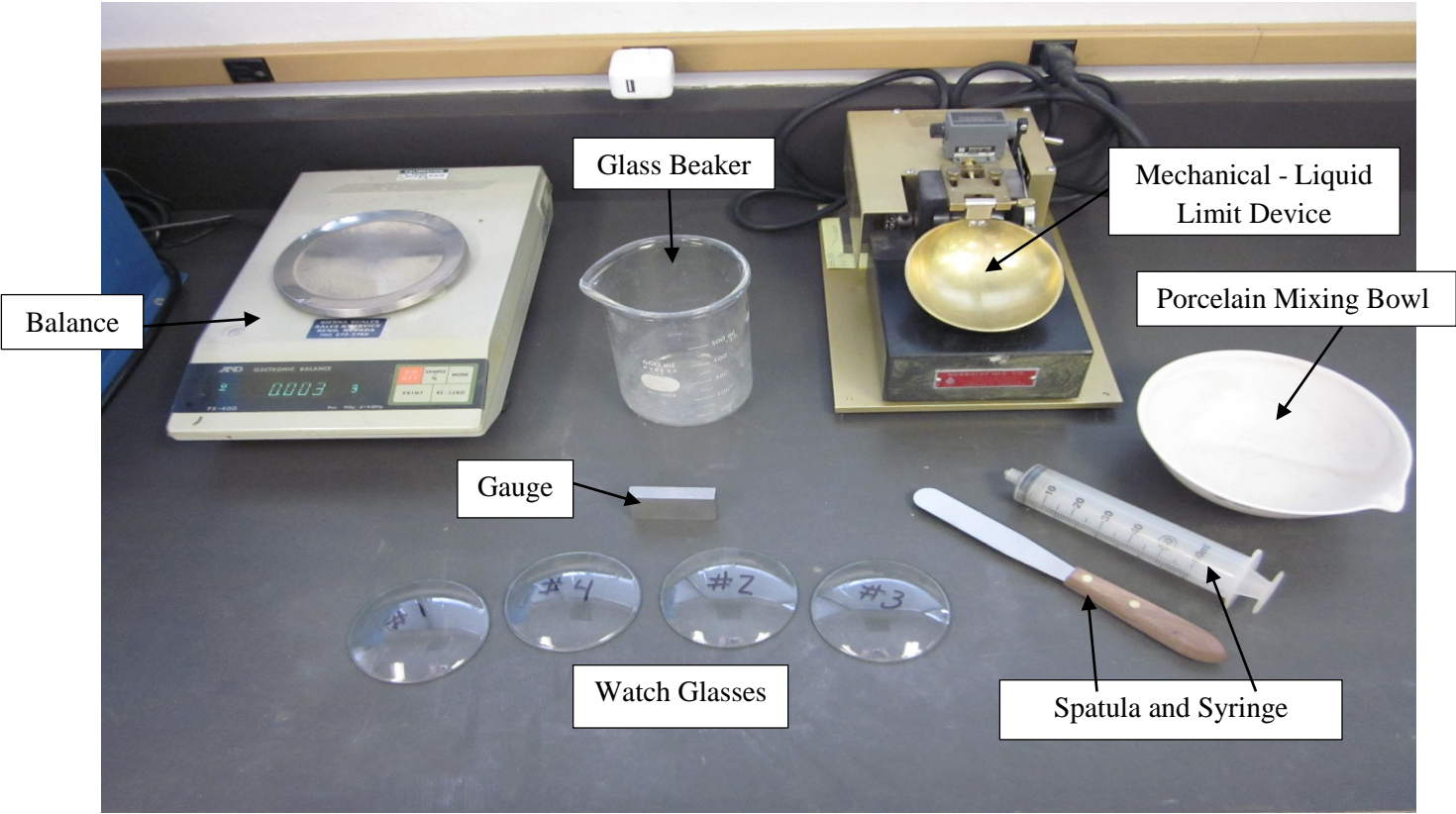

Figure 4



Figure 5  
Stack of Nested Sieve



Figure 6  
MPA with Revolving Drum



Figure 7  
Metal Mortar and Rubber-Covered Pestle