

SOLARIS Consortium

Final Project Report

**High-Early-Strength High-Performance Concrete for Rapid
Pavement Repair**

Prepared by:

Nader Ghafoori, Ph.D., P.E.

Meysam Najimi, Ph.D.

Matthew Maler, MS Student

Department of Civil and Environmental Engineering and Construction
University of Nevada Las Vegas
4505 Maryland Parkway
Box 454015
Las Vegas, Nevada 89154-4015



Final Report

January 16, 2017

TITLE

High-Early-Strength High-Performance Concrete for Rapid Pavement Repair



SOLARIS Consortium, Tier 1 University Transportation Center
Center for Advanced Transportation Education and Research
Department of Civil and Environmental Engineering
University of Nevada, Reno
Reno, NV 89557

Nader Ghafoori, Ph.D., P.E.
Professor of Civil Engineering
Department of Civil and Environmental Engineering and Construction
University of Nevada Las Vegas
4505 Maryland Parkway- Box 454015
Las Vegas, Nevada 89154-4015
Phone: (702)895-2531
Fax: (702) 895-3936
E- mail: nader.ghafoori@unlv.edu

DISCLAIMER:

The contents of this report reflect the views of the authors, who are responsible for the facts and accuracy of the information presented herein. This document is disseminated under the sponsorship of the U.S. Department of Transportation's University Transportation Centers Program, in the interest of information exchange. The U.S. Government assumes no liability for the contents or use thereof.

Table of Contents

List of Tables	VIII
List of Figures	XI
Chapter 1  Introduction, Economic Impacts, National Survey, and Literature Review .	1
1.1 Introduction	1
1.2 Economic Impacts	2
1.3 Background	4
1.3.1 National Survey.....	5
1.3.2 Literature Review	8
1.4 Cement Types in HES Concrete.....	17
1.4.1 Portland Cement.....	17
1.4.2 Proprietary Rapid Setting Cements.....	19
1.5 Typical HES Concrete Production Cost.....	20
Chapter 2  Materials, Mixture Design, Curing, and Testing Methods.....	22
2.1 Materials	22
2.1.1 Laboratory Temperature and Humidity.....	22
2.1.2 Water.....	22
2.1.3 Fine Aggregate	23
2.1.4 Coarse Aggregate	24
2.1.5 Cement Types	25
2.1.6 Admixtures	25
2.2 Batch Design.....	26
2.3 Curing Methods	26
2.3.1 Opening Time Curing.....	26
2.3.2 24-Hour Curing	29
2.3.3 28-Day Moist Curing.....	29
2.4 Testing Equipment & Methods	30
2.4.1 Mixing.....	30
2.4.1.1 Mixer.....	30
2.4.1.2 Mixing Time and Procedure.....	30
2.4.1.3 Consolidation.....	31
2.4.2 Fresh Properties of HES Concretes.....	32
2.4.2.1 Workability.....	32

2.4.2.2	Setting Times	32
2.4.2.3	Air Content and Unit Weight	33
2.4.2.4	Heat of Hydration	34
2.4.3	Hardened Properties of HES Concretes	35
2.4.3.1	Mechanical Properties.....	35
2.4.3.1.1	<i>Compression Test</i>	35
2.4.3.1.2	<i>Bending Test</i>	36
2.4.3.2	Volumetric Change Properties.....	36
2.4.3.2.1	<i>Drying Shrinkage</i>	36
2.4.3.3	Transport Properties	38
2.4.3.3.1	<i>Absorption</i>	38
2.4.3.3.2	<i>Water Permeability</i>	40
2.4.3.3.3	<i>Rapid Chloride penetration Test</i>	40
2.4.3.3.4	<i>Rapid Migration Test</i>	42
2.4.3.3.5	<i>Corrosion</i>	42
2.4.3.4	Durability Properties	46
2.4.3.4.1	<i>Abrasion Resistance</i>	46
2.4.3.4.2	<i>Resistance to Freezing and Thawing</i>	48
2.5	Summary of Experimental Program	51
Chapter 3	☐ Fresh Properties of HES Concretes	52
3.1	Required HRWR to Maintain Uniform Workability	52
3.2	Workability.....	53
3.3	Setting.....	54
3.4	Air Content and Unit Weight.....	57
3.5	Heat of Hydration.....	57
3.5.1	Opening Time Heat of Hydration.....	59
3.5.2	Maximum Heat of Hydration	62
Chapter 4	☐ Hardened Properties of HES Type V Portland Cement Concretes.....	67
4.1	Introduction	67
4.2	Results and Discussion	68
4.2.1	Compressive Strength.....	68
4.2.1.1	Effects of Cement Content.....	70
4.2.1.2	Effects of Accelerator Dosage.....	72
4.2.1.3	Effects of Air-Entraining Admixture	73

4.2.1.4. Effects of Hot Water Usage.....	74
4.2.1.5. Effects of Curing Age.....	75
4.2.2. Flexural Strength.....	75
4.2.3. Absorption and Volume of Permeable Voids.....	77
4.2.3.1. Effects of Cement Content.....	79
4.2.3.2. Effects of Accelerator Dosage.....	81
4.2.3.3. Effects of Air-Entraining Admixture.....	81
4.2.3.4. Effects of Hot Water Usage.....	82
4.2.3.5. Effects of Curing Age.....	82
4.2.4. Rapid Chloride Penetration Test.....	83
4.2.4.1. Effects of Cement Content.....	84
4.2.4.2. Effects of Accelerator Dosage.....	85
4.2.4.3. Effects of Air-Entraining Admixture.....	85
4.2.4.4. Effects of Hot Water Usage.....	86
4.2.4.5. Effects of Curing Age.....	86
4.2.5. Rapid Chloride Migration Test.....	86
4.2.5.1. Effects of Cement Content.....	88
4.2.5.2. Effects of Accelerator Dosage.....	89
4.2.5.3. Effects of Air-Entraining Admixture.....	89
4.2.5.4. Effects of Curing Age.....	90
4.2.6. Water Permeability.....	90
4.2.7. Drying Shrinkage.....	92
4.2.7.1. Effects of Cement Content.....	92
4.2.7.2. Effects of Accelerator Dosage.....	95
4.2.7.3. Effects of Hot Water Usage.....	96
4.2.7.4. Effects of Curing Age.....	96
4.2.7.5. Comparison with NDOT Specification.....	96
4.2.8. Corrosion Resistance.....	97
4.2.9. Frost Resistance.....	99
4.2.10. Abrasion.....	102
Chapter 5  Hardened Properties of HES Type III Portland Cement Concretes.....	104
5.1. Introduction.....	104
5.2. Results and Discussion.....	105
5.2.1. Compressive Strength.....	105
5.2.1.1. Effects of Cement Content.....	105

5.2.1.2. Effects of Air-Entraining Admixture	108
5.2.1.3. Effects of Curing Age	109
5.2.2. Flexural Strength	109
5.2.3. Absorption and Volume of Permeable Voids	111
5.2.3.1. Effects of Cement Content.....	112
5.2.3.2. Effects of Air-Entraining Admixture	114
5.2.3.3. Effects of Curing Age.....	114
5.2.4. Rapid Chloride Penetration Test	114
5.2.4.1. Effects of Cement Content.....	116
5.2.4.2. Effects of Air-Entraining Admixture	116
5.2.4.3. Effects of Curing Age.....	117
5.2.5. Rapid Chloride Migration Test	117
5.2.5.1. Effects of Cement Content.....	118
5.2.5.2. Effects of Air-Entraining Admixture	119
5.2.5.3. Effects of Curing Age.....	119
5.2.6. Water Permeability	120
5.2.7. Drying Shrinkage.....	121
5.2.7.1. Effects of Cement Content.....	122
5.2.7.2. Effects of Curing Age	123
5.2.7.3. Comparison with NDOT Specification	124
5.2.8. Corrosion Resistance.....	125
5.2.9. Frost Resistance	127
5.2.10. Abrasion.....	129
Chapter 6  Hardened Properties of HES Rapid Set Cement Concretes.....	131
6.1. Introduction	131
6.2. Results and Discussion	132
6.2.1. Compressive Strength.....	132
6.2.1.1. Effects of Cement Content.....	132
6.2.1.2. Effects of Air-Entraining Admixture	135
6.2.1.3. Effects of Curing Age.....	135
6.2.2. Flexural Strength	136
6.2.3. Absorption and Volume of Permeable Voids	137
6.2.3.1. Effects of Cement Content.....	138
6.2.3.2. Effects of Air-Entraining Admixture	140
6.2.3.3. Effects of Curing Age.....	140

6.2.4. Rapid Chloride Penetration Test	140
6.2.4.1. Effects of Cement Content.....	142
6.2.4.2. Effects of Air-Entraining Admixture	142
6.2.4.3. Effects of Curing Age.....	142
6.2.5. Rapid Chloride Migration Test	143
6.2.6. Water Permeability	144
6.2.7. Drying Shrinkage.....	145
6.2.7.1. Effects of Cement Content.....	146
6.2.7.2. Effects of Curing Age.....	148
6.2.7.3. Comparison with NDOT Specification	149
6.2.8. Corrosion Resistance.....	149
6.2.9. Frost Resistance	150
6.2.10. Abrasion.....	153
6.3. Concluding Remark	154
 Chapter 7  Comparison of HES Concretes.....	 155
7.1. Introduction	155
7.2. Properties.....	157
7.2.1. Compressive strength.....	157
7.2.2. Flexural strength	159
7.2.3. Absorption and Volume of Permeable Voids	160
7.2.4. Rapid Chloride Penetration Test	162
7.2.5. Rapid Chloride Migration Test	163
7.2.6. Water Permeability	165
7.2.7. Drying Shrinkage.....	166
7.2.8. Corrosion Resistance.....	167
7.2.9. Frost Resistance	168
7.2.10. Abrasion.....	170
7.3. Concluding Remarks	171
 References.....	 173
 Appendix A	 177

List of Tables

Table 1-1: America’s ASCE Infrastructure Report Card grades 1998-2013 (ASCE, 1998, 2001,2005,2009, 2013)	3
Table 1-2: Literature Review - Projects Table 1 of 3	9
Table 1-3: Literature Review - Projects Table 2 of 3	10
Table 1-4:Literature Review - Projects Table 3 of 3	11
Table 1-5: Literature Review - Laboratory Research Table 1 of 5	12
Table 1-6: Literature Review - Laboratory Research Table 2 of 5	13
Table 1-7: Literature Review - Laboratory Research Table 3 of 5	14
Table 1-8: Literature Review - Laboratory Research Table 4 of 5	15
Table 1-9: literature Review - Laboratory Research Table 5 of 5	16
Table 1-10: Cement Composition at a glance	18
Table 1-11: Literature Review - Project Cost	21
Table 2-1: Size Gradation of Coarse Aggregate.....	25
Table 2-2: Concrete Constituents and Proportioning Using Metric Units	27
Table 2-3: Concrete Constituents and Proportions Using British Units	28
Table 2-4: Experimental Program	51
Table 3-1: Water-to-Cement Ratio, HRWR Used, and Resulting Slump	54
Table 3-2: Initial and Final Setting Times for Type III and Type V Cement Concretes.	56
Table 3-3: Results for Unit Weight, Amount of Air-Entrainment Used, Change in HRWR, and Resulting Air Content	58
Table 3-4: Heat of Hydration at Opening Time and Maximum Heat of Hydration Including Elapsed Time	61
Table 4-1: Compressive Strength of Type V-HES Concretes (psi)	69
Table 4-2: Opening Time of Type V-HES Concretes and Range of Compressive Strengths at Opening Time	69
Table 4-3: Flexural Strength of Type V-HES Concrete.....	76
Table 4-4: Results of Absorption Test for Type V-HES Concretes Containing 2% Accelerator.....	78
Table 4-5: Results of Absorption Test for Type V-HES Concretes containing 2.8% Accelerator.....	79

Table 4-6: Passing Charges of Type V-HES Concretes.....	84
Table 4-7: Chloride Penetration Depth of Type V-HES Concretes.....	87
Table 4-8: Water Penetration Depth of Type V-HES Concretes.....	92
Table 4-9: Time to Failure for Type V-HES Concretes in Corrosion Test.....	98
Table 4-10: Abrasion Depth of Type V-HES Concretes.....	103
Table 5-1: Compressive Strength of Type III-HES Concretes (psi).....	106
Table 5-2: Opening Time of Type III-HES Concretes and Range of Compressive Strengths at Opening Times.....	107
Table 5-3: Flexural Strength of Type III-HES Concretes.....	110
Table 5-4: Results of Absorption Test for Type III-HES Concretes.....	112
Table 5-5: Passing Charge of Type III-HES Concretes.....	115
Table 5-6: Chloride Penetration Depth of Type III-HES Concretes.....	117
Table 5-7: Water Penetration Depth of Type III-HES Concretes.....	120
Table 5-8: Time to Failure of Type III-HES Concretes in Corrosion Test.....	126
Table 5-9: Abrasion Depth of Type III-HES Concretes.....	130
Table 6-1: Compressive Strength of Rapid Set HES Concretes (psi).....	133
Table 6-2: Opening Time of Rapid Set HES Concretes and Range of Compressive Strengths at Opening Times.....	133
Table 6-3: Flexural Strength of Rapid Set HES Concretes.....	136
Table 6-4: Results of Absorption for Rapid Set HES Concretes.....	138
Table 6-5: Passing Charge of Rapid Set HES Concretes.....	141
Table 6-6: Water Penetration Depth of Rapid Set HES Concretes.....	144
Table 6-7: Time to Failure of Rapid Set HES Concretes in Corrosion Test.....	149
Table 6-8: Abrasion Depth of Rapid Set HES Concretes.....	153
Table 7-1: Key Elements of Mixture Design, Fresh Properties, and Opening Time of the Selected HES Concretes.....	156
Table 7-2: Results of Absorption Test for the Selected HES Concretes.....	161
Table 7-3: Ultimate Mass Loss of the Selected HES Concretes Subjected to 25 Freezing and Thawing Cycles.....	169
Table 7-4: Ranking of the Selected HES Concretes for Different Properties.....	172

Table A- 1: Survey Responses for Massachusetts, Kentucky, Nebraska, and Florida ...	179
Table A- 2: Survey Responses for Massachusetts, Kentucky, Nebraska, and Florida ...	180
Table A- 3: Survey Responses for Alabama, Arkansas, Indiana, and California	181
Table A- 4: Survey Responses for Alabama, Arkansas, Indiana, and California	182
Table A- 5: Survey Responses for Kansas, Louisiana, Connecticut, and Illinois	183
Table A- 6: Survey Responses for Kansas, Louisiana, Connecticut, and Illinois	184
Table A- 7: Survey Responses for Iowa, Hawaii, Virginia, and Arizona.....	185
Table A- 8: Survey Responses for Iowa, Hawaii, Virginia, and Arizona.....	186
Table A- 9: Survey Responses for Idaho and Vermont	187
Table A- 10: Survey Responses for Idaho and Vermont	188

List of Figures

Figure 1-1: Spending for America’s Infrastructure 1945-2014 (CBPP.org).....	4
Figure 1-2: U.S. Map Showing Cements Used by State. (Information Via Survey.)	7
Figure 2-1: Sieve Analysis for the Fine Aggregate.....	23
Figure 2-2: Rotating Pan Mixer.....	31
Figure 2-3: Mechanical Consolidation Table.....	32
Figure 2-4: (Left) Abrams Slump Cone; (Right) Acme Penetrometer	33
Figure 2-5: Air Content Meter - Pressure Type.....	34
Figure 2-6: Heat of Hydration Set-Up	35
Figure 2-7: Compression Loading Machine.....	37
Figure 2-8: Flexure Schematic for 4-Point Loading (a.k.a. 1/3 Point Loading)	37
Figure 2-9: Dry Shrinkage Length Indicator	38
Figure 2-10: Absorption Equipment; Oven, Boiling Pot, and Balance with Buoyancy Basket	39
Figure 2-11: Water Permeability Test Apparatus	41
Figure 2-12: RCPT Set-Up and Schematic	43
Figure 2-13: RMT Set-Up and Schematic	44
Figure 2-14: Corrosion Set-Up and Schematic.....	45
Figure 2-15: Abrasion Resistance Testing Machine.....	47
Figure 2-16: Typical Trend for the Cooling of the Freeze/Thaw Samples	49
Figure 2-17: Cooler Used for Pre-Cooling of Freeze/Thaw Samples.....	50
Figure 2-18: Freezer Used to Freeze the Freeze/Thaw Samples.....	50
Figure 3-1: Initial and Final Setting Times for Type III and Type V	56
Figure 3-2: Air Content of Rapid Set concrete as a Function of Air-Entraining Admixture, Cement Factor 650 lb/yd ³	59
Figure 3-3: Heat of Hydration at Opening Time.....	64
Figure 3-4: Typical Heat of Hydration Trends for Non-Air-Entrained HES Concretes (650 lb/yd ³).....	65
Figure 3-5: Typical Heat of Hydration Trend for Air-Entrained HES Concretes (650 lb/yd ³).....	65

Figure 3-6: Maximum Heat of Hydration Temperature.....	66
Figure 4-1: Opening Time of Type V-HES Concretes.....	71
Figure 4-2: Compressive Strength of Type V-HES Concretes at 24 Hrs and 28 Days....	72
Figure 4-3: Flexural Strength of Type V-HES Concretes.....	77
Figure 4-4: Absorption and Volume of Permeable Void for Type V-HES Concretes.....	80
Figure 4-5: Passing Charges of Type V-HES Concretes.....	83
Figure 4-6: Chloride Penetration Depth of Type V-HES Concretes.....	88
Figure 4-7: Water Penetration Depth of Type V-HES Concretes.....	91
Figure 4-8: Drying Shrinkage of Type V-HES Concretes Transferred to Shrinkage Room at Opening Time.....	93
Figure 4-9: Drying Shrinkage of Type V-HES Concretes Transferred to Shrinkage Room at the Age of 24 Hrs.....	94
Figure 4-10: Drying Shrinkage of Type V-HES Concretes Transferred to Shrinkage Room at the Age of 28 Days.....	94
Figure 4-11: The Ultimate Shrinkage (1-Year) of Type V-HES Concretes.....	95
Figure 4-12: Drying Shrinkage of Type V-HES Concretes After 28 Days in Shrinkage Room.....	97
Figure 4-13: Time to Failure for Type V-HES Concretes in Corrosion Test.....	99
Figure 4-14: Mass Loss of Type V-HES Concretes Tested at the Age of 24 Hrs.....	101
Figure 4-15: Mass Loss of Type V-HES Concretes Tested at the Age of 28 Days.....	101
Figure 4-16: Ultimate Mass Loss of Type V-HES Concretes Subjected to 25 Freezing and Thawing Cycles.....	102
Figure 5-1: Opening Time of Type III-HES Concrete.....	107
Figure 5-2: Compressive Strength of Type III-HES Concretes at 24 Hrs and 28 Days.	108
Figure 5-3: Flexural Strength of Type III-HES Concretes.....	111
Figure 5-4: Absorption and Volume of Permeable Voids of Type III-HES Concretes.	113
Figure 5-5: Passing Charge of Type III-HES Concretes.....	115
Figure 5-6: Chloride Penetration Depth of Type III-HES Concretes.....	118
Figure 5-7: Water Penetration Depth of Type III-HES Concretes.....	121
Figure 5-8: Drying Shrinkage of Type III-HES Concretes Transferred to Shrinkage Room at Opening Time.....	122

Figure 5-9: Drying Shrinkage of Type III-HES Concretes Transferred to Shrinkage Room at the Age of 24 Hrs.....	123
Figure 5-10: Drying Shrinkage of Type III-HES Concretes Transferred to Shrinkage Room at the Age of 28 Days.....	124
Figure 5-11: The Drying Shrinkage of Type III-HES Concretes After 28 Days and 7.5 Months in Shrinkage Room.....	125
Figure 5-12: Failure Time of Type III-HES Concretes in Corrosion Test.....	126
Figure 5-13: Mass Loss of Type III-HES Concretes tested at the Age of 24 Hrs.....	128
Figure 5-14: Mass Loss of Type III-HES Concretes tested at the Age of 28 Days	128
Figure 5-15: Ultimate Mass Loss of Type III-HES Concretes Subjected to 25 Freezing and Thawing Cycles.....	129
Figure 5-16: Abrasion Depth of Type III-HES Concretes	130
Figure 6-1: Opening Time of Rapid Set HES Concretes.....	134
Figure 6-2: Compressive Strength Rapid Set HES Concretes at 24 Hrs and 28 Days ...	134
Figure 6-3: Flexural Strength of Rapid Set HES Concretes	137
Figure 6-4: Absorption and Volume of Permeable Voids Rapid Set HES Concretes	139
Figure 6-5: Passing Charge of Rapid Set HES Concretes	141
Figure 6-6: Rapid Set HES Concrete Samples Subjected to Rapid Chloride Migration Test (After Spraying Silver Nitrate).....	143
Figure 6-7: Water Penetration Depth of Rapid Set HES Concretes.....	145
Figure 6-8: Drying Shrinkage of Rapid Set HES Concretes Transferred to Shrinkage Room at Opening Time.....	146
Figure 6-9: Drying Shrinkage of Rapid Set HES Concretes Transferred to Shrinkage Room at the Age of 24 Hrs.....	147
Figure 6-10: Drying Shrinkage of Rapid Set HES Concretes Transferred to Shrinkage Room at the Age of 28 Days.....	147
Figure 6-11: The Drying Shrinkage of Rapid Set HES Concretes After 28 Days and 7.5 Months in Shrinkage Room.....	148
Figure 6-12: Time to Failure of Rapid Set HES Concretes in Corrosion Test	150
Figure 6-13: Mass Loss of Rapid Set HES Concretes Tested at the Age of 24 Hrs.....	151
Figure 6-14: Mass Loss of Rapid Set HES Concretes Tested at the Age of 28 Days.....	152

Figure 6-15: Ultimate Mass Loss of Rapid Set HES Concretes Subjected to 25 Freezing and Thawing Cycles.....	152
Figure 6-16: Abrasion Depth of Rapid Set HES Concretes.....	154
Figure 7-1: Compressive Strength of the Selected HES Concretes at 24 hrs	158
Figure 7-2: Compressive Strength of the Selected HES Concretes at 28 Days	158
Figure 7-3: Flexural Strength of the Selected HES Concretes	159
Figure 7-4: Void Contents of the Selected HES Concretes	162
Figure 7-5: Passing Charges of the Selected HES Concretes	163
Figure 7-6: Chloride Penetration Depth of the Selected HES Concretes	164
Figure 7-7: Water Penetration Depth of Selected HES Concretes.....	165
Figure 7-8: Drying Shrinkage of HES Concretes After 28 Days in Shrinkage Room ...	166
Figure 7-9: Drying Shrinkage of HES Concretes After 7.5 Months in Shrinkage Room	167
Figure 7-10: Failure Time of HES Concretes in Corrosion Test.....	168
Figure 7-11: Ultimate Mass Loss of the Selected HES Concretes Subjected to 25 Freezing and Thawing Cycles	169
Figure 7-12: Abrasion Depth of the Selected HES Concretes.....	170

Chapter 1 Introduction, Economic Impacts, National Survey, and Literature Review

1.1 Introduction

In the construction industry, High Early-Age Strength (HES) concrete was traditionally regarded as a concrete that achieves a loading strength in matter of days rather than weeks. However, in the last 10-15 years, this time has been reduced down to a matter of hours. The required minimum compressive strength is determined on a case-by-case basis depending on the project. In construction applications for structures and dwellings the minimum allowed by the International Building Code is 2500 psi (IBC 2012), while in road and bridge construction the minimum requirement is typically 3000 psi, and for airport construction is typically 4000 psi. Due to the accelerated strength gain of HES provided by chemical admixtures, the minimum opening strengths are often reduced since it is expected that the concrete continues to gain strength after the traffic load is introduced. Since the target of this investigation is high early-age strength concrete for the purposes of road and bridge deck repairs, this will be the main focus from this point on.

In this chapter, economic impacts associated with the extended lane closures and road construction will be discussed along with the past 30 years studies conducted on high early-age strength concrete, a national survey, and a brief discussion of ASTM types and proprietary rapid setting cements will also be provided.

The following chapters will discuss materials and methods, fresh properties, mechanical properties, transport properties, durability, and dimensional stability

properties of the studied high early-age strength concretes using different cement types and parametric variables, such as cement factor, accelerator dosage, air-entrainment, and age.

1.2 Economic Impacts

In the last 30 years the United States experienced two economic recessions. The First occurred in the mid-part of the 1980s whereas; the second occurred approximately 2008 to 2012. These recessions have caused highway and bridge maintenance programs to be deferred to a future date or to be neglected altogether. This combined with an infrastructure that was already aging and in need of repair, coupled with an over-burden in usage due to under predicted increases in population over time for some areas, is now leading to a highway infrastructure system that is literally crumbling. In 2013, the ASCE Report Card reported that at least one out of ten bridges in America fell in the “*Structurally Deficient*” category, thus receiving a grade of C+. This category implies that major maintenance, or rehabilitation, or in some cases replacement is required. The average age of U.S. bridges in use is 42 years old. It was also reported that about one-third United States highway system, approximately 1.3 million miles, received a grade of D (Poor condition or worse) (ASCE). Table 1-1 shows that while a minor improvement has occurred in the “Bridge” category of the report card over the last 18 years, the quality of roads has been fluctuating between D- and D+. For the last 18 years the overall grade for America’s infrastructure (all 16 categories) has been between D and D+.

Table 1-1: America’s ASCE Infrastructure Report Card grades 1998-2013 (ASCE, 1998, 2001,2005,2009, 2013)

ASCE Report Cards for America's Infrastructure							
Category	1998	2001	2005	2009	2009 Notes	2013	2013 Notes
Bridges	C-	C	C	C	<ul style="list-style-type: none"> Over 25% of America's bridges are borderline unsafe or severely outdated. 	C+	<ul style="list-style-type: none"> Over 10% (> 600,000) of America's bridges are "structurally deficient". The cost to repair ≈ \$75 billion.
Roads	D-	D+	D	D-	<ul style="list-style-type: none"> Over 4 billion hours lost per year due to traffic congestion. Estimated value ≈ \$78 billion. Estimated over \$185 billion needed to improve America's highways. 	D	<ul style="list-style-type: none"> Over 40% of America's urban highways suffer congestion. Estimated cost ≈ \$101 billion in lost time and fuel per year. Estimated ≈ \$170 billion needed yearly for major improvements.
Overall for all Categories ¹	D	D+	D	D		D+	

1 - Not all categories are shown in this table.

The report also gives a financial estimate of \$101 billion dollars spent on additional fuel and lost time due to traffic congestion and delays stemming from road and bridge repairs. This estimated amount is in addition to the cost of repairs which are budgeted from the local, state, and federal tax bases. These cost are covered by the general public and businesses alike, and in many cases these economic impacts cannot be deferred until a more convenient time. Excess gas consumption and commercial services are not the only things impacted; core infrastructure systems such as public transportation, school buses, and emergency responders are also impacted. For these, the end result is again excess gas consumption, plus increased vehicle maintenance, and

decreased productivity. Thus, tax payers now see a third, albeit discrete, financial burden that must be paid through the tax base. These over-burdens are essentially bleeding the budget of valuable funds that could be better spent on longer lasting repairs with shorter closure times. Figure 1-1 shows that the United States is at a 30 year low with respect to allocating funds to infrastructure repair and maintenance. These low points (1984 and 2014) coincide with the previously mentioned economic recession periods. The ASCE report card for 2013 is also a reflection of this trend.

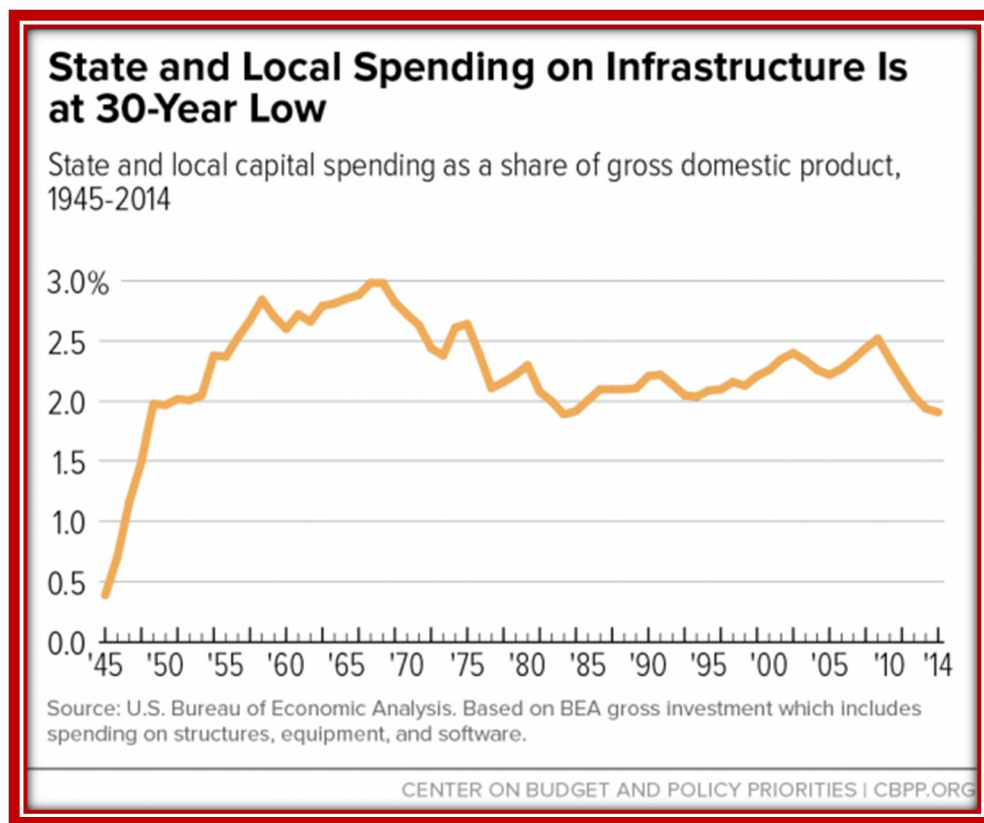

Figure 1-1: Spending for America's Infrastructure 1945-2014 (CBPP.org)

1.3 Background

The following is a review of the responses to a questionnaire to the U.S. Departments of Transportation and a literature review of studies into high early-age strength concrete dating back 30 years.

1.3.1 National Survey

In the Fall of 2015, and again in the Spring 2016, a survey was sent out to State Departments of Transportation (DOTs) and regional offices of the Federal Highway Administrations (FHWA). The focus of the survey was to obtain information on the high early-age strength repairs used by different state agencies. The survey questions and results listed by State can be found in Appendix A. The survey provided the following keys pieces of information that were used for material selection and proportioning of this study:

- ◆ All States used/allowed high early-age strength concrete for pavement repairs, and almost all used/allowed high early-age strength concrete for bridge deck repairs.
- ◆ Opening times vary with geographic location and cement type used. Times as low as 4-6 hrs have been documented using Type-III PC and 8-10 hrs using Type-I PC during summer placement. Opening times as low as 2.5 hours have been seen using rapid setting cements. Some States base opening time on compressive or flexural strength, while some impose a 4-6 hr minimum (at least one cold weather State has a 12 hr min). Typical max opening times are 24, 48, and some cases 72 hrs (at least one hot weather State has a 12 hr max.) Many States require strength testing at intervals of 24, 48, and/or 72 hrs regardless of opening time.
- ◆ The required compressive strength at opening to traffic ranged between 1500–3500 psi (4000 psi for deep repairs), with the majority being 3000 psi.
- ◆ Many States do not have flexural strength requirements. When required, the range is 380-600 psi.

- ◆ Few States have a specification for drying shrinkage. When specified the range is 0.03-0.05 % at 28-days after placement.
- ◆ Type(s) I, II, III Portland Cement, and in some cases proprietary bag mixes such as Rapid Set, are the most prevalently used for high early-age strength concrete in bridge and road repair. See Figure 1-2 for a graphic representation.
- ◆ The cement factors used for HES repairs ranged between 600-900 lb/yd³, with the lower values 600-750 lb/yd³ being more favorable due to economics.
- ◆ Most States allow for the use of alternate/supplementary cementitious materials within specified limits. Some States do not allow silica fume.
- ◆ Most states do not specify minimum water-to-cement ratios. They do, however, specify a maximum value of 0.40-0.45.
- ◆ All States have some form of curing method involving curing compounds, wet burlap, wet plastic, or curing blankets.
- ◆ Minimum R-value for curing blanket not generally specified, the value ranged from 1-5.
- ◆ Nearly all States allowed for the use or accelerating admixtures for pavement and bridge deck repairs. Some allowed the use for pavement only. Nearly all States require non-chloride accelerators when used.
- ◆ Nearly all States allowed for the use of retarding admixtures – although not typically needed with high early-age strength concrete using Portland cement.
- ◆ In regions that have freeze/thaw weather cycles, the required air-content ranged between 5 and 8.5 %.

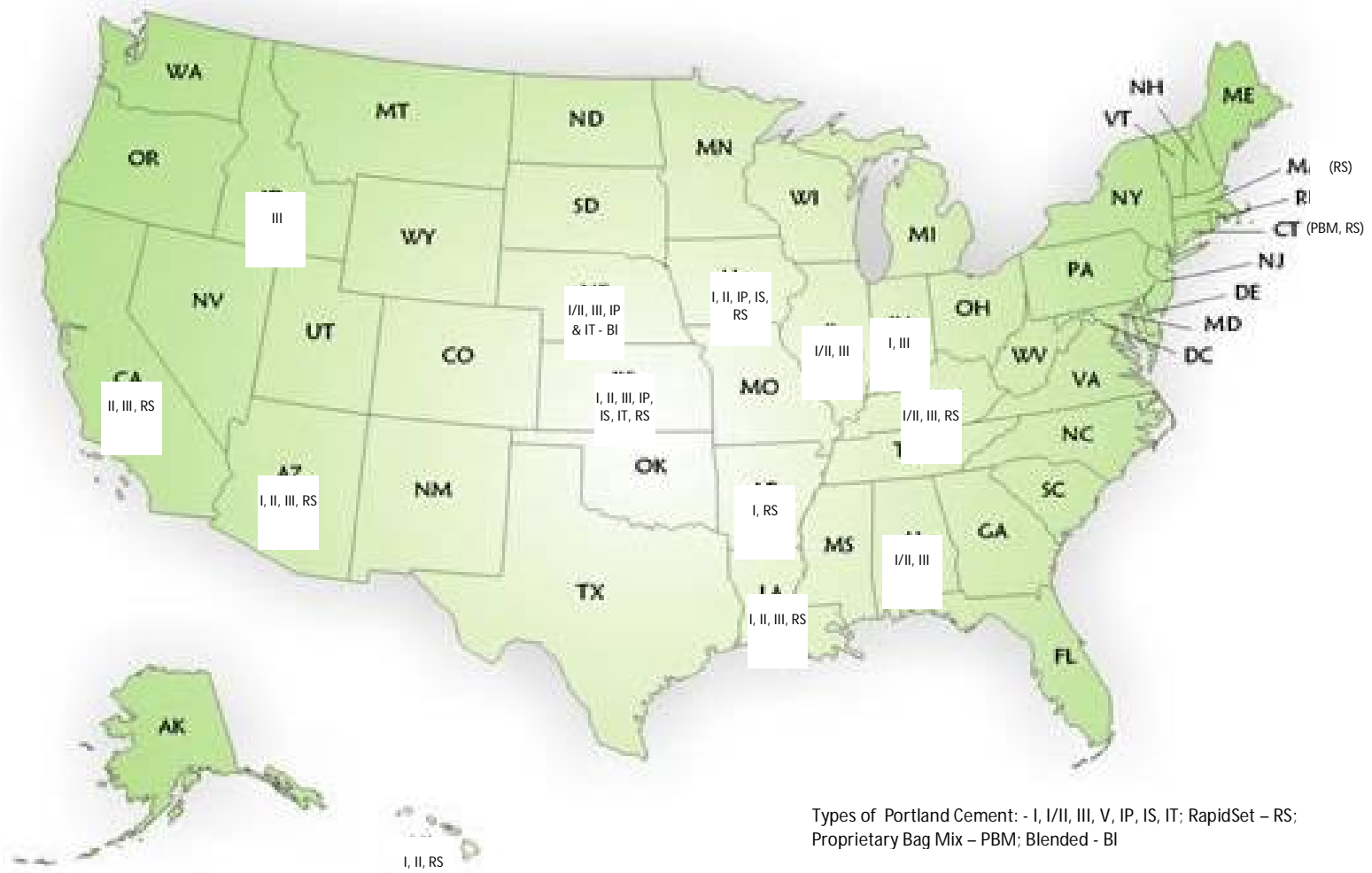

Figure 1-2: U.S. Map Showing Cements Used by State. (Information Via Survey.)

1.3.2 Literature Review

The literature review for this project dates back approximately 30 years. Although the literature covered a broad use of high early-age strength concrete for road and bridge repairs, there were four key points of information gleaned that were used in material selection and mixture proportioning designs for this study:

- ◆ Cement type, cement factor, and supplementary cementitious materials.
- ◆ Water-to-cementitious materials ratio
- ◆ Opening times
- ◆ Strengths achieved

Tables 1-2 through 1-4 provide the aforementioned information from various highway and bridge repair projects throughout the U.S. In addition to this information, the geographic location, year, and a brief description of the project is also provided. The results shown reflect the responses from the survey with respect to types of cement used, supplementary cementitious material limits, and water-to-cement ratio. In addition to field reports, there was also literature documenting laboratory research investigating high early-age strength concrete. A majority of these were for highway and bridge deck repairs. Tables 1-5 through 1-9 provide the key points previously mentioned with respect to laboratory research projects. In addition to this information, the laboratory name and location, year, and a brief description of the research project are also provided. The information shown reflect the results with respect to types of cement used, supplementary cementitious materials limits, water-to-cement ratio, test time, and strength achieved.

Table 1-2: Literature Review - Projects Table 1 of 3

Table for Projects								
Project Location	Project Date	Project Name	Brief Description	Cement Type	w/c	Strength Achieved	Test Time	Reference
IOWA	1987	Creating cement for fast track construction		Class C fly ash 70lbs/yd ³ w/Type III 640 lbs/yd ³	0.43 to 0.45	C: 3 467 psi F: 607 psi	24 hrs	Knuston, 1987
Osceola	1987	Osceola Airport project		Class C fly ash 70lbs/yd ³ w/Type III 640 lbs/yd ³	0.43 to 0.45	F: 415psi & 780psi	12 hrs & 26 hrs	Pearson, 1987
Michigan	1987	Michigan road project		No fly ash Type III 710 lbs/yd ³	0.38	F: 425 psi	12 hrs	
Cedars Rapids, Iowa	1989	Fast track	Urban road construction	Class C fly ash 73lbs/yd ³ w/Type III 641 lbs/yd ³	0.41	C: 3550 psi & 4660 psi F: 420 psi & 530 psi	C & F: 12 hrs & 24 hrs	Grove, 1989
Cedars Rapids, Iowa		Fast track 2		Class C fly ash 80lbs/yd ³ w/Type III 742 lbs/yd ³	0.38	C: 4990 psi & 5260 psi F: 570 psi & 690 psi	C & F: 12 hrs & 24 hrs	
Vermilion, Ohio	1994	Early Strength gain of rapid Highway Repair concrete	Road repair	Type III 900 lb/yd ³	0.4	MOR : 400 psi	4 hrs	Whiting, 1994
Vermilion, Ohio				900 lb/yd ³ of a blended cement	0.27	C: 2000 psi	4 hrs	
Vermilion, Ohio				750 lb/yd ³ of a rapid set cement	0.4	C: 2000 psi	4 hrs	
Vermilion, Ohio				Type III 870 lb/yd ³	0.38	C: 2000 psi	4 hrs	
Augusta, Georgia				850 lb/yd ³ blended cement	0.29	C: 2000 psi	6 hrs	
Vermilion, Ohio				650 lb/yd ³ rapid set cement	0.5	C: 2000 psi	6 hrs	
Augusta, Georgia				Type I 750 lb/yd ³	0.38	C: 1000 psi	4 hrs	
St. Louis County, Missouri	May, 2004	Bridge #: J611515	Latex Modified Concrete - Very High Early Strength placement on the bridge decks.	Latex Modified Concrete - Very High Early Strength (LMC-VE)		Pull off tensile strength : Ave. = 115 psi	6 hrs old	Wenzlick, 2006
St. Charles County, Missouri	May, 2004	Bridge #: J611444	Repair and overlay a 5-lane bridge with LMC-VE.	Latex Modified Concrete - Very High Early Strength (LMC-VE) modified with Rapid Set.				

C for compressive strength, F for flexural strength, MOR Modulus of Rupture, 1 MPa = 145 psi

Table 1-3: Literature Review - Projects Table 2 of 3

Table for Projects								
Project Location	Project Date	Project Name	Brief Description	Cement Type	w/c	Strength Achieved	Test Time	Reference
New Jersey		Fast track concrete for pavement repair		Type I 799 lb/yd ³	0.41	C: 3865 psi F: 380 psi	24 hrs	Ansari, 1997
New Jersey				Type I 705 lb/yd ³	0.41	C: 3607 psi	24 hrs	
Storm Lakem, IA	1980	Fast track concrete pavement	US-71 bonded overlay	Type III	0.45	F: 350 psi	7.5 hrs	ACPA, not dated
Barksdale, AFB (IA)	1992		Runway keel reconstruction	Special blended	0.27	F: 450 psi	4 hrs	
Cedars Rapids, IA	1988		Highway 100 intersection replacements	Type III	0.38	F: 400 psi	12 hrs	
Manhattan, KS	1990		SR-81 Arterial reconstruction	Type III	0.44	F: 450 psi	24 hrs	
Lansing, MI	1989		Lane addition to I-496	Type III	0.45	F: 550 psi	19 hrs	
Denver, CO	1992		I-25 to I-70 interchange Ramp reconstruction	Type III	0.32	F: 2500 psi	12 hrs	
Dallas county, IA	1987		Single-route access road reconstruction	Type III	0.425	F: 350 psi	9 hrs	
Rawlins, WY	1992		Interstate 80 widening	Type III	0.47	F: 3000 psi	24 hrs	
Erie County, PA	1991		SR 832 & I-90 Interchange reconstruction	Type III	0.37	F: 3000 psi	24 hrs	
Dane County, MO	1991		I-70 bonded overlay	Type III	0.4	F: 3500 psi	18 hrs	
Cooper County, WI	1992		Runway 18/36 extension	Type III	0.455	F: 3500 psi	12 hrs	
North Hampton, VA	1990		SR -13 bonded overlay	Type III	0.42	F: 3000 psi	24 hrs	
Menominee, NE	1992		US-81 reconstruction	Type II	0.423	F: 3500 psi	24 hrs	
Smithfield, NC	1990		US-70 inlay of asphalt intersection approaches	Type III	0.35	F: 450 psi	48 hrs	

C for compressive strength, F for flexural strength, MOR Modulus of Rupture, 1 MPa = 145 psi

Table 1-4:Literature Review - Projects Table 3 of 3

Table for Projects								
Project Location	Project Date	Project Name	Brief Description	Cement Type	w/c	Strength Achieved	Test Time	Reference
Us Highway 30, Indiana. From Illinois border past Dyer.	Aug, 2014	INDOT Project No. R-35341	US Highway 30. Full depth lane repair using HES. 2-Lanes each direction. Three sites visited.	Type I/II	0.343	F: 300, 330, 360, 450 psi	4, 5, 6, 8 hrs	Todd, 2015
	Sept, 2014			Type I/II	0.343	F: 240, 320, 390, 400, 490 psi	4, 5, 6, 8, 24 hrs	
	Oct, 2014			Type I/II	0.343	F: 240, 320, 380, 400 psi	6, 8, 11, 24 hrs	
LaPorte County, IN	June, 2014	Bridge No. 157	Evaluation of Internally Cured High Performance Concrete (ICHPC) Bridge Decks	Type II	0.403	5000, 6200, 7400, 8200 psi	3, 5, 7, 14, 28 days	Todd, 2015
Starke County, IN	Nov, 2014	Bridge No. 31		Type II	0.403	4200, 4900, 6300, 6900, 7800, 8300 psi	5, 7, 14, 28, 56, 91 days	
Starke County, IN	April, 2014	Bridge No. 70		Type II	0.403	C: 7340, 7780, 8050 psi	28, 56, 91 days	
Starke County, IN	June, 2014	Bridge No. 79		Type II	0.403	C: 8230, 9120, 9120 psi	28, 56, 91 days	

C for compressive strength, F for flexural strength, MOR Modulus of Rupture, 1 MPa = 145 psi

Table 1-5: Literature Review - Laboratory Research Table 1 of 5

Table for Laboratory Research								
Location	Date	Project Name	Drief Discription	Cement Type	w/c	Strength Achieved	Test Time	Reference
	1988	High Early Strength Latex Modified Concrete		Type III	0.34	C: 2330 psi & 3740 psi	12 hrs & 24 hrs	Sprinkel, 1988
Iowa	1988	Cement for fast track concrete	Evaluation of Special Cements for HES concrete - Iowa DOT	Pyrament	0.297	C: 1940 psi & 2520 psi F: 510 psi & 570 psi	C & F: 12 hrs & 24 hrs	Jones, 1988
					0.285	C: 2360 psi & 2470 psi F: 525 psi & --- psi	C & F: 12 hrs & 24 hrs	
					0.271	C: 1870 psi & 2400 psi F: 345psi & --- psi	C & F: 12 hrs & 24 hrs	
				Ideal R/S	0.376	C: 2820 psi & 3570 psi F: 500 psi & --- psi	C & F: 12 hrs & 24 hrs	
					0.439	C: 2680 psi & 3140 psi F: 124 psi & 244 psi	C & F: 12 hrs & 24 hrs	
					0.377	C: 2760 psi & 3690 psi F: 430 psi & --- psi	C & F: 12 hrs & 24 hrs	
		Concrete Structure, Properties, and Materials	Textbook excerpt	Type I 360 lb/yd ³ w/slump 225mm	0.6	10,21,32,45 Mpa	1,3,7,28 days	Mehta, 1992
				Type I 360 lb/yd ³ slump 22mm + 2% superplastilizer / weight	0.45	20,35,43,55 Mpa	1,3,7,28 days	
				Type I	0.45	16,28,37,52 Mpa	1,3,7,28 days	
	1993	High Early Strength Concrete		Type III	<0.4	C: 3500 psi	12 hrs	Hall, 1993
	1993	High Early Strength Concrete		Type I	0.45	C: 5340 psi	28 days	Ozyildirim, 1993
					0.4	C: 6490 psi		
					0.35	C: 7810 psi		
				Type II	0.45	C: 5400 psi		
					0.4	C: 6010 psi		
					0.35	C: 8180 psi		

C for compressive strength, F for flexural strength, MOR Modulus of Rupture, 1 MPa = 145 psi

Table 1-6: Literature Review - Laboratory Research Table 2 of 5

Table for Laboratory Research								
Location	Date	Project Name	Drief Discription	Cement Type	w/c	Strength Achieved	Test Time	Reference
University of Tennessee	2002	Abrasion Resistance of Fast Track Portland Cement Concrete	Study the abrasion resistance of HES concrete using Type I and III Portland cement.	Type I	0.35	900, 3097; 6688 psi	8, 12 hr; 28 days	Tays, 2002
				Type I	0.35	1488, 3173; 5277, 5346, 6696 psi	8, 12 hrs; 3, 7, 28 days	
				Type I	0.35	1656, 3250; 6710 psi	8, 12 hr; 28 days	
				Type I	0.325	1992, 3547; 7409 psi	8, 12 hr; 28 days	
				Type III	0.4	2725, 3779, 4588; 5348, 5935, 6726 psi	6, 8, 12 hrs; 3, 7, 28 days	
				Type III	0.4	3318, 4075, 4677; 5476, 6002, 6935 psi	6, 8, 12 hrs; 3, 7, 28 days	
				Type III	0.375	3335, 4602, 5101; 7345 psi	6, 8, 12 hrs; 28 days	
				Type I w/ Air Ent.	0.35	2464, 4043; 8033 psi	8, 12 hrs; 28 days	
				Type I w/ Air Ent.	0.35	3073, 4158; 8200 psi	8, 12 hrs; 28 days	
				Type I w/ Air Ent.	0.35	2381, 3305, 4280; 8350 psi	6, 8, 12 hrs; 28 days	
				Type I w/ Air Ent.	0.325	3231, 3963, 4836; 9211 psi	6, 8, 12 hrs; 28 days	
				Type III w/ Air Ent.	0.4	3824, 4758; 8191 psi	6, 8 hrs; 28 days	
				Type III w/ Air Ent.	0.4	4874, 5411; 8570 psi	6, 8 hrs; 28 days	
Type III w/ Air Ent.	0.375	5385, 6014; 9025 psi	6, 8 hrs; 28 days					

C for compressive strength, F for flexural strength, MOR Modulus of Rupture, 1 MPa = 145 psi

Table 1-7: Literature Review - Laboratory Research Table 3 of 5

Table for Laboratory Research								
Location	Date	Project Name	Drief Discription	Cement Type	w/c	Strength Achieved	Test Time	Reference
Institut National des Sciences Appliques de Lyon		New application of calcium sulfoaluminate cement.	Development of concrete with high early strength: 40 Mpa, 6h after its preparation, and higher than 55 Mpa after 24h.	80% of Calcium Sulfoaluminate (CSA). 20% of OPC (Type I).	0.37	Mix 1 : 40Mpa. Mix 2 : 35 Mpa. Mix 3 : 46 Mpa.	6 hours	Pera, 2004
Departement of civil engineering, Michigan State University		Evaluation of high-early strength PCC mixtures used in full depth repairs		Type I and Type III	0.4	38-50Mpa	28 days	Buch, 2006
ODOT - Office of Materials Management Cement & Concrete Section		High Early Strength Concrete Overlays	Evaluation of concrete overlay mixes that are intended to reach a strength that would allow traffic at a very early age (2 to 4 hours)	SDC III : using Type III cement	0.36	4540 psi	12h	ODOT, 2007
				MSC III : using Type III cement	0.36	3735 psi	12h	
				LMC RS : using CTS Rapid Set cement	0.39	3630 psi	12h	
		High Early Strength Concrete without Steam Curing	Develop mix proportioning information for production of high early strength concrete for precast concrete pipe production.	C-I	0.43	19N/mm2	7days	Kumar, 2012
				C-II	0.38	34.1N/mm2	7days	
				C-IV	0.38	33.3N/mm2	7days	
				SC-I	0.37	50.4N/mm2	7days	
				SC-I	0.37	44.1N/mm2	7days	
				SC-II	0.38	51.3N/mm2	7days	
				SC-I	0.39	27.1N/mm2	24h	
				SC-II	0.38	31.7N/mm2	24h	
				SC-II	0.38	28.4N/mm2	24h	
		Fast Track Construction with High-Strength Concrete Mixes Containing Ground Granulated Blast Furnace Slag	Fast track construction	Portland cement		70.9MPa	1 day	Soutsos, not dated
				20%GGBS		76.6MPa	2 day	
				35%GGBS		75.7MPa	3 day	
				50%GGBS		55.4MPa	4 day	
				70%GGBS		36.1MPa	5 day	

C for compressive strength, F for flexural strength, MOR Modulus of Rupture, 1 MPa = 145 psi

Table 1-8: Literature Review - Laboratory Research Table 4 of 5

Table for Laboratory Research								
Location	Date	Project Name	Drief Discription	Cement Type	w/c	Strength Achieved	Test Time	Reference
	2006	Selection of Durable Closure Pour Materials for Accelerated Bridge Construction	The procedure and methods for selecting durable CP materials.	Grade 1 : AASHTO T22 ASTM C39		55Mpa<Comp. strength<69Mpa	56 days	Zhu, 2010
	2006			Grade 2 : AASHTO T22 ASTM C39		69Mpa<Comp. strength<97Mpa	56 days	
	2006			Grade 3 : AASHTO T22 ASTM C39		97Mpa<Comp. strength	56 days	
	2007			Grade 1 : AASHTO T22		24Mpa<Comp. strength<55Mpa	28 days	
	2007			Grade 2 : AASHTO T22		55Mpa<Comp. strength	28days	
	2007			Grade 3 : AASHTO T22		24Mpa<Comp. strength	early ages	
				Mix 1 : I	0.31	44.8MPa	7days	
				Mix 1 : I	0.31	61.3MPa	28days	
				Mix 2 : I	0.35			
				Mix 3 : II	0.31			
				Mix 4 : I/II (Lafarge Sugar Creek SF)	0.32	28.4MPa	7days	
				Mix 4 : I/II (Lafarge Sugar Creek SF)	0.32	36.3MPa	28days	
				Mix 5 : I/II (Lafarge Sugar Creek SF)	0.35	34.9MPa	7days	
				Mix 5 : I/II (Lafarge Sugar Creek SF)	0.35	50.4MPa	28days	
				Emaco T430 mix		10.1MPa	7days	
				Emaco T430 mix		15.9MPa	28days	
				LMC-VE		30.4MPa	7days	
				LMC-VE		30.3MPa	28days	
				RSLP Mix 1		26.3MPa	7days	
				RSLP Mix 1		29.2MPa	28days	
		RSLP Mix 2		72.8MPa	7days			
		RSLP Mix 2		77.6MPa	28days			

C for compressive strength, F for flexural strength, MOR Modulus of Rupture, 1 MPa = 145 psi

Table 1-9: literature Review - Laboratory Research Table 5 of 5

Table for Laboratory Research								
Location	Date	Project Name	Drief Discription	Cement Type	w/c	Strength Achieved	Test Time	Reference
University of Nevada Las Vegas	2007	Resistance to External Sodium Sulfate Attack for Early-Opening-to-Traffic Portland Cement Concrete	The effects of sodium sulfate attack on physial and durability properties of HES concrete	Type I	0.35	17, 27.9 MPa	8, 12 hrs	Ghafoori, 2007
				Type I	0.35	21.2, 28.7 Mpa	8, 12 hrs	
				Type I	0.35	16.4, 22.8, 29.5 Mpa	6, 8, 12 hrs	
				Type I	0.325	22.3, 27.3, 33.4 Mpa	6, 8, 12 hrs	
				Type III	0.40	26.4, 32.8 Mpa	6, 8 hrs	
				Type III	0.40	33.6, 37.3 Mpa	6, 8 hrs	
				Type III	0.375	37.1, 41.5 Mpa	6, 8 hrs	
				Type V	0.35	15.8, 25.7 Mpa	8, 12 hrs	
				Type V	0.35	20.8, 26.9 Mpa	8, 12 hrs	
				Type V	0.35	15.3, 21.6, 28.6 Mpa	6, 8, 12 hrs	
Type V	0.325	19.5, 25.7, 31.2 Mpa	6, 8, 12 hrs					
	2014	Experimental Study on the Development of Compressive Strength of Early Concrete age using Calcium-Based Hardening Accelerator and High Early Strength Cement	Development of high early strength without steam curingof precast concrete.	C3S rich HES cement w/ 0% Acclerator	0.32	1, 3, 12, 29, 37 Mpa	6, 9, 12, 18, 24 hrs	Min, 2014
				C3S rich HES cement w/ 1% Acclerator	0.32	2, 9, 23, 32, 37 Mpa	6, 9, 12, 18, 24 hrs	
				C3S rich HES cement w/ 3% Acclerator	0.32	7, 15, 22, 28, 35 Mpa	6, 9, 12, 18, 24 hrs	
				C3S rich HES cement w/ 5% Acclerator	0.32	12, 18, 24, 31, 40 MPa	6, 9, 12, 18, 24 hrs	
West Lafayette, Indiana	2015	Evaluation of HES concretes using accelerators and high temperatures.	Mortar testing of HES concrete w/ accelerator and high temperatures - an extention of field projects by INDOT	Type I/II w/ and w/o 1% SO ³				Todd, 2015

C for compressive strength, F for flexural strength, MOR Modulus of Rupture, 1 MPa = 145 psi

1.4 Cement Types in High Early-Age Strength Concrete

In high early-age strength concrete Portland cement is by far the most commonly used with several types to choose from, however, it is not the only cement available.

1.4.1 Portland Cement

When referencing concrete construction in the United States utilizing Ordinary Portland Cement, the recognized standards are set forth by the American Society for Testing and Materials (ASTM). ASTM divides Ordinary Portland Cement (OPC) into five types. These types are categorized by their four main components, in addition to their particle size (a.k.a. Blaine Fineness). Table 1-10 shows the five types of Portland cement along with four main components listed in descending order of importance from left to right. In the cases of Type I and Type III, this is also the descending order of abundance. Each of these four categories has a specified range in which each type of cement must maintain for proper *Type* identification.

Table 1-10 also indicates the Blaine fineness, which represents the particle size. The higher the Blaine value the smaller the particle. The smaller the particle the faster the cementitious material can achieve full hydration, which leads to higher heat of hydration and an increased rate of strength development. From the table it can be seen that Type III, which is designed for high early-age strength, has both a high C_3S and a high Blaine Fineness value. Type V, is noticeably lower with respect to C_3S and Blaine Fineness when compared to the other types. These two values are what steer conventional thinking away from using Type V for high early-age strength (HES) products. Nevada requires Type V Portland cement for all construction activities.

Table 1-10: Cement Composition at a glance

Type by ASTM	Class	% C ₃ S	% C ₂ S	% C ₃ A	% C ₄ AF	% C _S	Blaine Fineness m ² /kg	Characteristics	Common Applications
Type I	General purpose	40 - 63	9 - 31	6 - 14	5 - 13	≈3	300 - 421	High C ₃ S leading to faster strength development	General construction (buildings, bridges, pavements, precast units, etc.)
Type II	Moderate Sulfate Resistance	37 - 68	6 - 32	2 - 8	7 - 15	≈3	318 - 480	Low C ₃ A - maintained below 8%, usually modified from Type I	Structures exposed to low-medium levels of sulfate ions (exposure from soil or water)
Type III	High Early Strength	46 - 71	4 - 27	0 - 13	4 - 14	≈4	390 - 644	High C ₃ S and smaller particle size leading to higher hydration heat and faster strength development	Cold weather placement, situations in which time constraints do not allow for long strength development periods
Type IV	Low Hydration Heat	37 - 49	27 - 36	3 - 4	11 - 18	≈3	319 - 362	Low C ₃ S - maintained below 50% and low C ₃ A, slow reacting leading to slow strength development	Structures in which dry shrinkage and micro cracking from high hydration heat and rapid progression of rheology/chemistry should be avoided. Petroleum well heads and dams are good examples.
Type V	High Sulfate Resistance	43 - 70	11 - 31	0 - 5	10 - 19	≈3	275 - 430	Very low C ₃ A - maintained below 5%	Structures exposed to medium-high levels of sulfate ions (exposure from soil or water)
CSA	Very High Early Strength	≈30*	≈45	0*	≈2	≈15	3000+	Extremely high fineness leads to high hydration heat and rapid setting and strength development. Setting 15-40 minutes	Rapid repairs of roads and bridges decks. Repairs in which long curing times will have high financial burdens.
CFA	Regulated-Set	≈5*	Adjusted as Needed				3000+	Same as CSA. Setting 2-40 minutes	

* C₃S and C₃A are in the form C₄A₃S

(ACI, 2002)(RapidSet.com)(Mindess,2003)(Bescher,2014)

1.4.2 Proprietary Rapid Setting Cements

There are several proprietary cementitious products on the market today that are not Portland cement, even though they share almost the same ingredients and are developed through the same kiln processes. The main differences in the production process are the kiln temperatures at the addition of ingredients and the time duration that those temperatures are held. Calcium Fluoroaluminate (CFA) Cement and Calcium Sulfoaluminate (CSA) Cement are both considered rapid setting, or rapid hydrating, cements that can achieve structural strengths (load bearing) in as little as 1 hour and 3 hours, respectively.

Rapid Set, manufactured by CTS Cement and sold commercially, is an example of a CSA cement that has achieved structural strengths in as little as 1 hour. It's designed for use in rapid highway and airport runway repairs. It has also been used in high-volume public structures such as sport stadiums and retail stores.

CFA cements have setting times as fast as 2 minutes up to 40 minutes. These cements are "set regulated" by using soluble sulfates and citric acid. CFA cements are blended specifically per situation with a precise setting time and can be produced directly in the kiln, or from modified Portland cement Type I clinker.

4x4 Concrete is a patented process developed by BASF Chemicals. This process claims 4000 psi in 4 hours using local source aggregate materials, ordinary Portland cement, and their (BASF) chemical admixtures. This aggressive strength development is originally intended for highway and runway repairs, but 4x4 Concrete can be used in various applications.

In comparison to ordinary Portland cements, many of these products and processes have a significantly higher dollar amount associated with them when compared to ordinary Portland cement. In addition, some of their long-term properties may have been compromised in exchange for rapid strength development. Therefore, they tend to be used as emergency repairs and in high priority situations such as inner city freeway exchanges and airport runways, or situations in which a significant dollar amount is associated with the elapsed closure time.

1.5 Typical High Early-Age Strength Concrete Production Cost

As part of the literature review, a projects table was developed. Some of these projects discussed cost either as a whole, or by the cubic yard of concrete. Table 1-11 provides information on cost and size of a few projects. The table also gives project location and a brief description. It can be seen that these projects took place in areas subject to freezing and therefore exposure to de-icing salts. The cost per cubic yard of these projects justifies the continuing development of high early-age strength concrete in an attempt to see a better return on investment through longer product life.

Table 1-11: Literature Review - Project Cost

Table for Economics								
Project Location	Project Date	Project Name	Drief Discription	Volume Used	Cost of Project	Cost	Total Project Time	Reference
Osceola	May-87	Airport Project			\$552,000.00			Pearson, 1988
Michigan	May-88	Road project			\$275,000			Pearson, 1988
Buena vista County Cedar Rapids, Iowa	1989	Paving the intersections			\$1.9 M			Grove
Dane County		Extension of runway on the regional airport		14,400 yd ³	\$1.8 M			Hall, 1991
St. Louis County, Missouri	7-May-04	J611515	Latex Modified Concrete - Very High Early Strength placement on the bridge decks.	Br.No. A10562: 2613 yd ²	\$243,009	\$93/yd ²	1 Night.	Wenzlick, 2006
				Br.No. A10512: 1182 yd ²	\$135,930	\$115/yd ²	Several days (3-4 days).	
				Br.No. A10513: 1182 yd ²	\$135,930	\$115/yd ²	Several days (3-4 days).	
St. Charles County, Missouri	May-04	J611444	Repair and overlay a 5-lane bridge with LMC-VE.	Br.No. A3582: 1800 yd ²	\$136,800	76/yd ²		Wenzlick, 2006
				Br.No. A3582: 10 yd ³	\$1,430	143/yd ³		
Laboratory	2014	Development of Compressive Strength of Early Concrete age using Calcium-Based Hardening Accelerator and HES Cement	Development of high early strength without steam curing of precast concrete.			\$146 - \$168 / yd ³ (from economic analysis)	4 mixes tested: @ 12 hrs 3 achieve 3000 psi; @ 24 hrs all exceed 5000 psi	Min, 2014
California	pre-2014		Runway - compare HES PC concrete and CSA concrete			\$204 / yd ³ for PC (est. 20-year life), \$283 / yd ³ for CSA (est. 40-year life)		Bescher, 2014

Chapter 2 Materials, Mixture Design, Curing and Testing

Methods

Chapter 2 of this study discusses material properties and storage, concrete mixture proportioning and design, three curing methods attributed for different ages, and testing methods and equipment.

2.1 Materials

The materials section of this report discusses the section and classification of the materials used in this study.

2.1.1 Laboratory Temperature and Humidity

The laboratory was climate controlled to maintain an ambient temperature of $24^{\circ} \pm 1.7^{\circ} \text{ C}$ ($75^{\circ} \pm 3^{\circ} \text{ F}$), and a humidity of $15 \pm 5\%$.

2.1.2 Water

The water used for mixing in this study was municipal tap water. This is standard practice for the local construction industry. The water was dispensed into plastic containers and allowed to acclimate to lab temperature for a minimum of 24 hours prior to use.

The water used for testing was also municipal tap water as described above. There were two exceptions, test that required a sodium hydroxide solution and test that required the use of a humidifier. Distilled water was used for these situations.

2.1.3 Fine Aggregate

The fine aggregate used in this study was obtained from a local quarry in Sloan, Nevada. ASTM C136 (Standard Test Method for Sieve Analysis of Fine and Course Aggregates) and ASTM C33 (Standard Specifications for Concrete Aggregates) were used for determination of suitability with respect to size distribution. The fine aggregate was found to be within the limits set by the standard as shown in Figure 2-1.

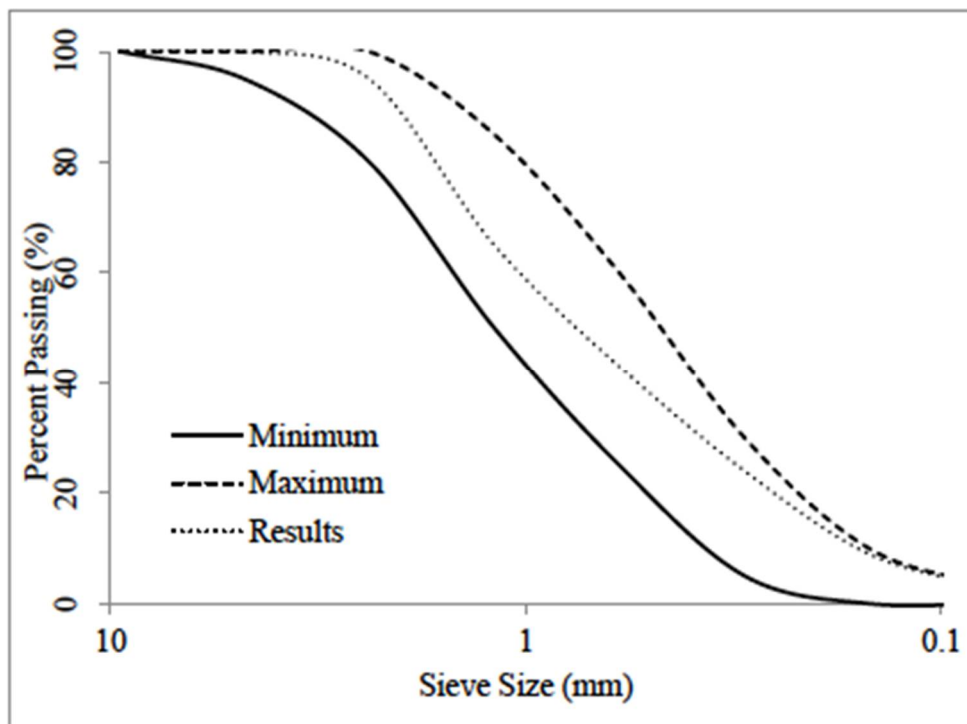

Figure 2-1: Sieve Analysis for the Fine Aggregate

ASTM C128 (Density, Relative Density (Specific Gravity), and Absorption of Fine Aggregate) was used to determine the absorption properties of the fine aggregate.

The results were as follows:

◆ Relative Density (Specific Gravity) Oven-Dry	2.76
◆ Relative Density (Specific Gravity) Saturated-Surface-Dry	2.76
◆ Apparent Relative Density (Apparent Specific Gravity)	2.82
◆ Absorption	0.81%

The fine aggregate was dried to a moisture content of 0.1 – 0.01 % before it was stored in the laboratory in sealed 5-gallon plastic buckets in order to acclimate to the laboratory room temperature for a minimum of 24 hours prior to use.

2.1.4 Coarse Aggregate

The coarse aggregate used in this study was also obtained from a local quarry in Sloan, Nevada. The coarse aggregate was received as ASTM #67 and ASTM #7 – for nominal sizes of ¾” and ½”, respectively. The coarse aggregate was dried to a moisture content of 0.1 – 0.01 % prior to sieving. The coarse aggregate was sieved using ¾”, ½”, 3/8”, and #4 U.S. sieves. Aggregates above or below these sieve sizes were discarded. For ASTM #7 coarse aggregate, to keep the ½” size would have caused the resulting size distribution of the ½” – ¾” aggregate used for testing to be skewed towards the ½” size.

Upon sieving, coarse aggregate was stored in sealed, 55-gallon steel barrels by size. For the purpose of concrete batching, coarse aggregate was brought into the laboratory and stored in sealed, 5-gallon plastic buckets and allowed to acclimate to the laboratory temperature for a minimum of 24 hours prior to use. Table 2-1 shows the recombined proportions, based on ASTM #67, that were used.

Table 2-1: Size Gradation of Coarse Aggregate

ASTM Sieve Size	ASTM #67	ASTM #7	Recombined Distribution
1"			
3/4"	USED		5%
1/2"	USED	DISCARD	35%
3/8"	USED	USED	30%
#4	USED	USED	30%
#8		DISCARD	
Pan	DISCARD	DISCARD	

2.1.5 Cement Types

The cements used in this project were Portland cement Type III and Type V, and a proprietary calcium sulfoaluminate (CSA) cement. In addition, two blended cement combinations of Type V and CSA were also investigated. Sierra Ready-Mix, a local supplier, provided the Type V Portland cement, whereas CalPortland Cement Manufacturing, out of California, provided the Type III. The CSA cement was provided by CTS Cement from California. It is marketed under the name Rapid Set.

2.1.6 Admixtures

The following chemical admixtures were used. The admixtures were stored in the laboratory in 9.5 L (2.5 gal.) sealed plastic containers.

Master Set AC534	Non-Chloride Accelerator
Master Glenium 7920	Polycarboxylate High-Range-Water-Reducer (HRWR)
Master Air AE200	Air-Entrainment (AE)
Master Set Delvo	Hydration Stabilizer / Set Retarder

2.2 Batch Design

Tables 2-2 and 2-3 show the resulting batch designs used for this study in two unit systems. Nomenclature for the batch IDs used in this study will be as follows:

Air Cement Cement Accelerator
Entrainment - Type - Factor - Amount (%)

Therefore, an air-entrained mixture of Type V at 386 kg/m³ (650 lb./yd³) with 2% accelerator/cwt. has the ID: AE-V-650-2.0

The “AE” prefix is omitted when air-entraining admixtures is not used.

2.3 Curing Methods

Upon casting all samples were troweled smooth on the exposed surface and covered with plastic film that was held in place with a rubber band. Three different curing types; namely opening time curing, 24-hour curing, and 28-day moist curing were utilized. Their descriptions can be found in the following sections.

2.3.1 Opening Time Curing

Curing for the Opening Time (OT) involved insulating test samples, while remaining in their molds, with a layer of curing blanket. The OT is defined as the elapsed time, starting when the water is added to the cement, needed for the concrete to reach a minimum compressive strength of 20.68 MPa (3000 psi).

Table 2-2: Concrete Constituents and Proportioning Using Metric Units

	Cement Material	Water	Coarse Agg.	Fine Agg.	High Range Water Reducer (w/ AE)	Air Entrainment When Used	Accelerator
			CA / FA Ratio = 55/45				
Units: kg / m ³					(L / m ³)		
Type V-2.0% Accelerator w/c = 0.275	385.6	120.6	1140.8	933.4	3.24 (3.24)	2.1	7.71
	445.0	136.2	1087.5	889.7	2.91 (2.80)	2.5	8.90
	504.3	151.8	1034.1	846.1	2.47 (2.14)	2.8	10.09
	563.6	167.5	980.8	802.4	2.03 (1.87)	3.1	11.27
Type V-2.8% Accelerator	385.6	120.6	1140.8	933.4	3.24 (3.24)	1.5	10.80
	504.3	151.8	1034.1	846.1	2.64 (2.42)	1.5	14.12
Type III w/c = 0.35	326.3	128.9	1157.0	946.7	2.20 (2.14)	0.8	6.53
	385.6	148.9	1096.9	897.5	1.87 (1.65)	1.9	7.71
	445.0	168.9	1036.8	848.3	1.65 (1.37)	2.3	8.90
							Retarder (L / m ³)
Rapid Set w/c = 0.4	326.3	144.8	1123.3	919.1	1.87 (1.70)	0.055	1.21
	385.6	167.7	1057.1	864.9	2.20 (1.81)	0.110	1.21
Type V / Rapid Set Blend (VRS) w/c = 0.3375 for VRS 50/50, w/c = 0.3063 for VRS 75/25	(50/50) 192.82 Type V, 192.82 Rapid Set	144.1	1098.9	899.1	2.75 (2.53)	0.110	0.60
	(75/25) 289.22 Type V, 96.41 Rapid Set						
	132.4	1119.9	916.3	3.19 (3.08)	0.165	None	

Table 2-3: Concrete Constituents and Proportions Using British Units

	Cement Material	Water	Coarse Agg.	Fine Agg.	High Range Water Reducer (w/ AE)	Air Entrainment When Used	Accelerator
			CA / FA Ratio = 55/45				
Units: lbs / yd ³					(gal / yd ³)		
Type V-2.0% Accelerator w/c = 0.275	650.0	203.2	1922.9	1573.3	5.46 (5.46)	0.43	1.56
	750.0	229.6	1833.0	1499.7	4.90 (4.72)	0.50	1.80
	850.0	255.9	1743.0	1426.1	4.16 (3.61)	0.57	2.04
	950.0	282.3	1653.1	1352.5	3.42 (3.15)	0.63	2.28
Type V-2.8% Accelerator	650.0	203.2	1922.9	1573.3	5.46 (5.46)	0.31	2.18
	850.0	255.9	1743.0	1426.1	4.45 (4.08)	0.30	2.85
Type III w/c = 0.35	550.0	217.3	1950.2	1595.6	3.71 (3.61)	0.17	1.32
	650.0	251.0	1848.9	1512.7	3.15 (2.78)	0.39	1.56
	750.0	284.7	1747.6	1429.8	2.78 (2.31)	0.45	1.80
							Retarder (gal / yd ³)
Rapid Set w/c = 0.4	550.0	244.1	1893.4	1549.1	3.15 (2.87)	0.01	0.24
	650.0	282.7	1781.7	1457.8	3.71 (3.05)	0.02	0.24
Type V / Rapid Set Blend (VRS) w/c = 0.3375 for VRS 50/50, w/c = 0.3063 for VRS 75/25	(50/50) 325 Type V, 325 Rapid Set	243.0	1852.3	1515.5	4.64 (4.26)	0.02	0.12
	(75/25) 487.5 Type V, 162.5 Rapid Set						
	223.1	1887.6	1544.4	5.38 (5.19)	0.03	None	

For cylinders, the insulation consisted of wrapping the samples with layers of curing blankets (R-Value = 3.4) before placing them in a curing box lined with ¾” Styrofoam. The cube-shaped samples were placed into the described curing box. Layers of curing blankets were placed between the box and the sample, including the top of the sample, prior to closing the box with its lid. Beam-shaped specimens were wrapped around their long axis with two layers of curing blankets and the ends (short dimensions) taped closed.

Once test samples were insulated, they were placed on a wooden table and covered by an additional layer of curing blanket to prevent any draft effects from the laboratory’s climate control system.

2.3.2 24-Hour Curing

The 24-Hour (24 H) curing method had the same procedure as the OT curing method for the duration of opening time. Afterward, the curing blanket was removed and the test specimens, while remaining in their molds, were kept in the laboratory environment to reach 24-hours of age prior to testing.

2.3.3 28-Day Moist Curing

Upon casting, test samples were kept in their mold, with no insulation, for 24 hours. Upon de-molding, they were kept in a moist curing room till they reached the age of 28 days prior to testing.

2.4 Testing Equipment & Methods

The following sections discuss the mixing equipment and testing procedures used to evaluate fresh and hardened properties of the studied high early-age strength concretes.

2.4.1 Mixing

This section covers the mixing equipment and procedure.

2.4.1.1 Mixer

A pan-style counter-current mixer with a capacity of 0.0283 m³ (1 ft³) and a constant speed of 60 RPM was used. Figure 2-2 presents the rotating pan mixer used in this study.

2.4.1.2 Mixing Time and Procedure

The following mixing procedure was adopted in the ordered mentioned.

1. Combined coarse aggregate and 1/3 mixing water (add air-entraining admixture if needed).
2. Mixed for 2 minutes.
3. Added fine aggregate and 1/3 mixing water (add hydration stabilizer if needed).
4. Mixed for 2 minutes.
5. Added cement (Type V 1st for the blended cements) and the remaining mixing water.
6. Mixed for additional 3 minutes.
7. Added accelerator and HRWR during the first minute of mixing cementitious materials.



Figure 2-2: Rotating Pan Mixer

2.4.1.3 Consolidation

Upon molding, specimens were densified for a period of approximately 7 seconds, longer as workability decreased, using a vibrating table operating at 6200 Hertz as shown in Figure 2-3.



Figure 2-3: Mechanical Consolidation Table

2.4.2 Fresh Properties of High Early-Age Strength Concretes

The following section discusses the equipment and test methods used to evaluate fresh properties of the studied concretes.

2.4.2.1 Workability

To determine workability, the slump test was performed using the Abrams cone, as shown in Figure 2-4, using ASTM C143/AASHTO T119. Material was removed from the mixer immediately after mixing and the test was completed within two minutes.

2.4.2.2 Setting Times

The initial and final times of setting test was performed using an Acme Penetrometer in accordance with the ASTM C403. To produce the test sample, fresh concrete was wet-sieved through a #4 U.S. sieve, densified in a 152 mm x 152 mm x 152

mm (6 in. x 6 in. x 6 in.) mold, and tested immediately thereafter. The test apparatus is also shown in Figure 2-4.



Figure 2-4: (Left) Abrams Slump Cone; (Right) Acme Penetrometer

2.4.2.3 Air Content and Unit Weight

The air content and unit weight of the studied freshly-mixed concretes were identified by using a pressure-type air-content meter in accordance with ASTM C231. This device, which had a sample size of 0.007 m^3 (0.25 ft^3), was also used to determine unit weight of the trial HES concretes. The device is shown in Figure 2-5.



Figure 2-5: Air Content Meter - Pressure Type

2.4.2.4 Heat of Hydration

Heat of hydration of the studied high early-age strength concretes were evaluated using 102 mm x 102 mm (4 in. x 4 in.) cylindrical samples in accordance with ASTM

C186. Figure 2-6 shows the heat of hydration set-up, including a USB-501-TC-LCD thermocouple data collector, used in the study.



Figure 2-6: Heat of Hydration Set-Up

2.4.3 Hardened Properties of High Early-Age Strength Concretes

The following sections discuss the equipment and testing methods used to evaluate hardened properties of the studied high early-age strength concretes.

2.4.3.1 Mechanical Properties

The two mechanical properties, using compression and bending test, that were investigated in this study are presented in the following sections.

2.4.3.1.1 Compression Test

Cylindrical specimens with dimensions of 102 mm x 203 mm (4in. x 8 in.) were used to evaluate compressive strengths of the studied concretes at different ages in accordance with ASTM C39. Figure 2-7 shows the compression-loading machine used in this study. The loading capacity of the machine was 2,224 kN (500,000 lbs). For

compression testing, the loading rate was maintained between 0.276-0.345 MPa (40-50 psi/sec.). A minimum of four samples were used to obtain the average compressive strength of the studied high early-age strength concretes.

2.4.3.1.2 Bending Test

The compression testing machine was also used to evaluate the flexural strength of beam-shaped specimens having dimensions of 102 mm x 102 mm x 356 mm (4 in. x 4 in. x 14 in.) using ASTM C78. The loading rate was kept constant between 0.014-0.021 MPa (2-3 psi/sec.) Figure 2-8 shows the schematic diagram of the 4-point (a.k.a. one-third-point) loading used for the flexure testing. Four samples were tested to obtain the average flexural strength of the high early-age strength concretes.

2.4.3.2 Volumetric Change Properties

For this study, one volumetric stability test, to obtain drying shrinkage of the studied high early-age strength concretes, was conducted.

2.4.3.2.1 Drying Shrinkage

The studied high early-age strength concretes were evaluated for their dimensional stability using the drying shrinkage test in accordance with ASTM C157. Prisms with dimensions of 76 mm x 76 mm x 286 mm (3 in. X 3in. X 11¼ in.) were cured at (OT, 24H, 28D) before they were stored in a chamber having an ambient temperature of $24^{\circ} \pm 1.7^{\circ} \text{ C}$ ($75^{\circ} \pm 3^{\circ} \text{ F}$) and a relative humidity of $50 \pm 5 \%$. A digital length indicator as shown in Figure 2-9 was used to evaluate the length change of the prisms. The length indicator read in increments of 0.0025 mm (0.0001 in.). Four samples were used to evaluate the average drying shrinkage of the studied HES concretes at different ages.



Figure 2-7: Compression Loading Machine

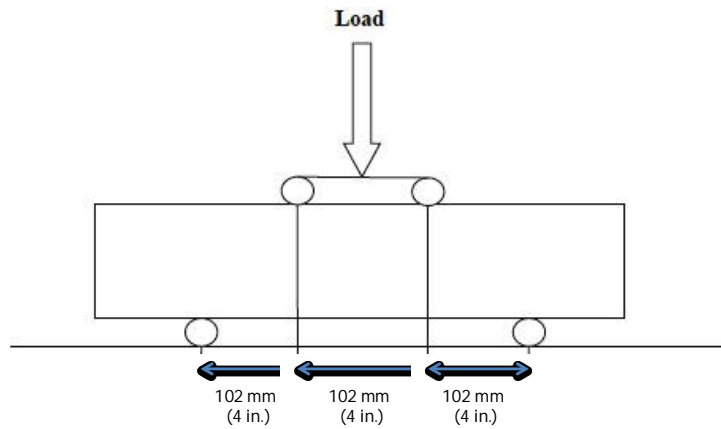

Figure 2-8: Flexure Schematic for 4-Point Loading (a.k.a. 1/3 Point Loading)



Figure 2-9: Dry Shrinkage Length Indicator

2.4.3.3 Transport Properties

For the studied high early-age strength concretes, five transport properties were evaluated. These properties were: Absorption, Water Permeability, Rapid Chloride Penetration, Rapid Migration, and Corrosion Tests.

2.4.3.3.1 Absorption

The absorption properties of the studied high early-age strength concretes were evaluated in accordance with ASTM C642 using cylindrical specimens with a diameter of 102 mm (4 in.) and a height of 51 mm (2 in.). These properties included Absorption After Immersion, Absorption After Immersion and Boiling, and Volume of Permeable

Pore Space (Voids). The procedure used to evaluate absorption properties was as follows in the order mentioned:

- Samples were placed in an oven at 80° C (176° F) for 7 days, then weighed.
- Samples were soaked in regular tap water at laboratory temperature for 7 days before they were towel dried to saturated surface dry SSD condition and weighed.
- Samples were boiled for 4 hours and held for 20 hours, before they were weighed in SSD condition again.
- Samples were placed in a wire mesh basket and immersed in water to obtain the buoyancy weight.

Figure 2-10 shows the equipment used to evaluate absorption properties of the test specimens.



Figure 2-10: Absorption Equipment; Oven, Boiling Pot, and Balance with Buoyancy Basket

2.4.3.3.2 Water Permeability

The water permeability of the studied high early-age strength concretes was conducted in accordance with EN 12390-8:2000 using cube shaped specimens of 152 mm x 152 mm x 152 mm (6 in. x 6 in. x 6 in.). The water permeability apparatus, with 3 samples, is shown in Figure 2-11. The air-pressure for the system was maintained at 5 bars during testing. The test was conducted for 3 days. Once stopped, the sample was removed, split in two equal halves using the compression machine. As water penetration discolored the concrete, the depth of this discoloration was immediately marked on both halves and measured. The standard states to avoid taking measurements at aggregate-paste interfaces and where voids connect to the surface being tested. The tested surface was chosen based on the fewest visible voids. Three samples per curing type (OT, 24H, 28D) for each batch design were tested.

2.4.3.3.3 Rapid Chloride Penetration Test

For the studied high early-age strength concretes, the Rapid Chloride Penetration Test (RCPT) was conducted on 102 mm (4 in.) x 51 mm (2 in.) cylindrical specimens using ASTM C1202. Four samples were used to obtain the average RCPT results. Figure 2-12 shows the RCPT set-up. The Sodium Chloride (NaCl) solution was at 3.0% and the Sodium Hydroxide (NaOH) solution was at a concentration of 0.3 M. The current was directed through the NaCl (Cathode/Catholyte) side to the NaOH (Anode/Anolyte) side (negative - to - positive). The sample was placed into the acrylic molds with the bottom of sample on the NaCl side and the troweled top on the NaOH side, see the schematic in Figure 2-12.



Figure 2-11: Water Permeability Test Apparatus

2.4.3.3.4 Rapid Migration Test

Rapid Migration Test (RMT) of the studied high early-age strength concretes studied were conducted in accordance with NT Build 492. The cylindrical samples had dimensions of 102 mm (4 in.) x 51 mm (2 in.) and 4 samples were used to determine average RMT results. Figure 2-13 shows the Rapid Migration Test set-up. The Sodium Chloride (NaCl) solution was at 10.0% and the Sodium Hydroxide (NaOH) solution was at a concentration of 0.3 M. The current was directed through the NaCl (Cathode/Catholyte) side to the NaOH (Anode/Anolyte) side (negative-to-positive). The sample was placed into the rubber molds with the bottom of sample on the NaCl side and the troweled top on the NaOH side (see the schematic diagram in Figure 2-13.)

Once the test was completed, the samples were promptly removed and split in half using a compression machine. Both halves were sprayed with a silver nitrate (AgNO_3) solution at a concentration of 0.1 M. The AgNO_3 reacted with the Cl^- which penetrated into the sample and discolored the sample. This discoloration was measured from the bottom of the sample. For this study measurements were taken approximately 4 mm apart.

2.4.3.3.5 Corrosion

The corrosion tests of the studied high early-age strength concretes were conducted using 102 mm (4 in.) x 152 mm (6 in.) cylindrical specimens in accordance to FM 5-522. The test set-up is shown in Figure 2-14 along with a schematic illustrating the cross-section of the sample to clarify re-bar location. The re-bar used in this study was typical 12.7 mm ($\frac{1}{2}$ in. or #4) Grade 60, and the salt water was 5% NaCl. The depth of the salt water was maintained to 3 in. The voltage was 30 volts and the test continued

until the measured current was equal-to or greater-than the initial current. Current readings were taken every 24-hours. There were four samples per curing type to obtain average corrosion results.

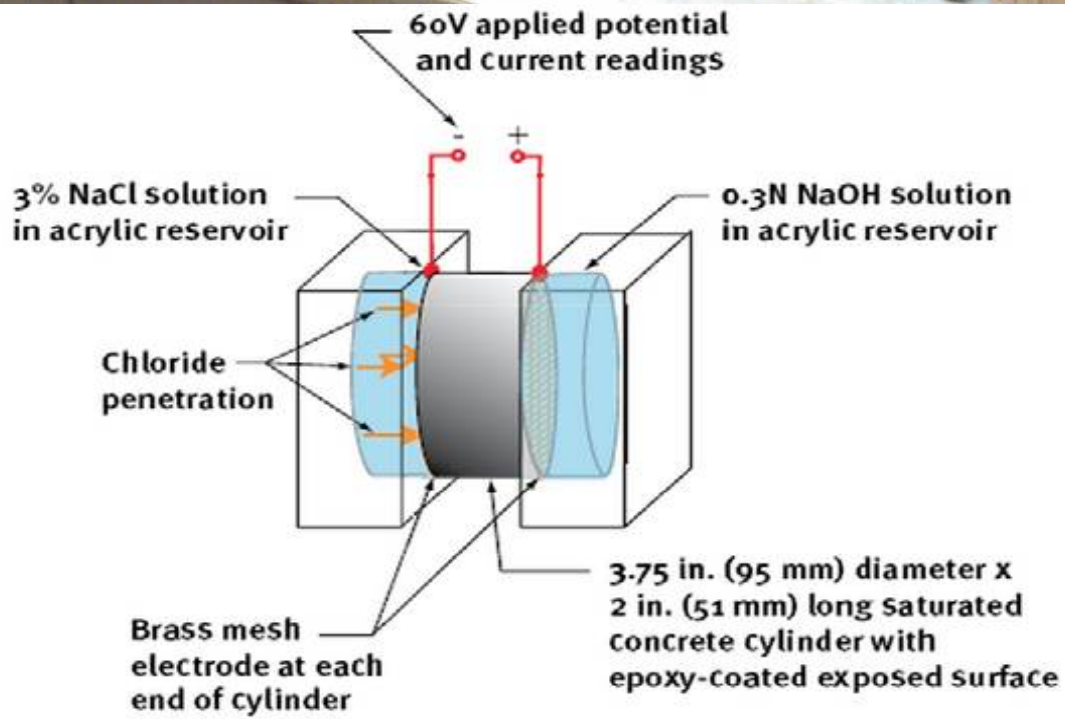
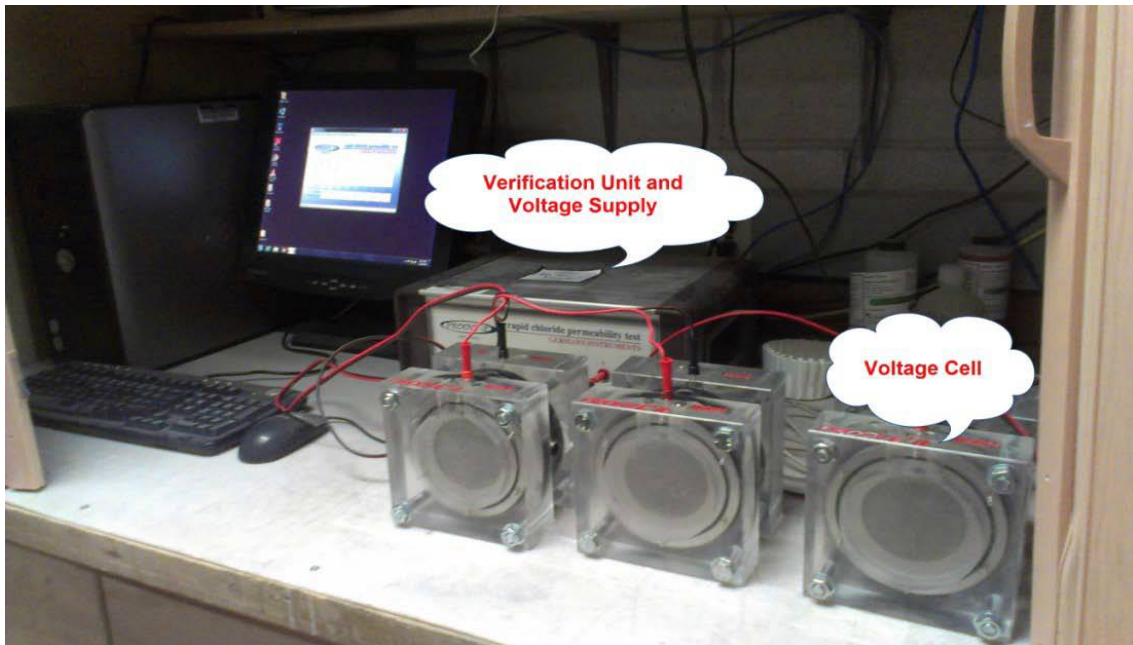
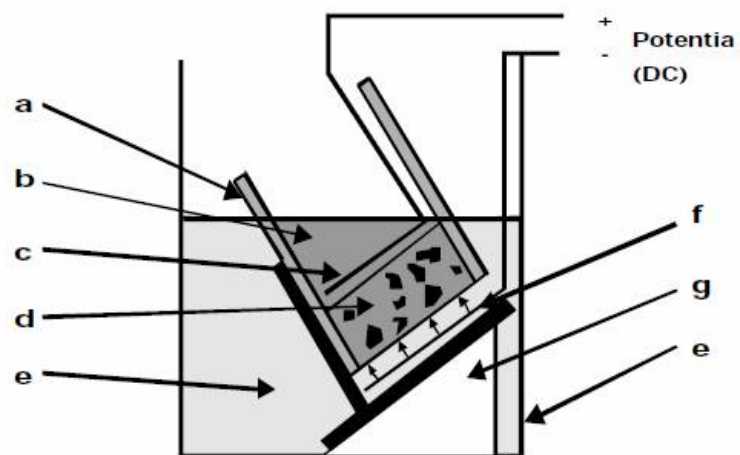

Figure 2-12: RCPT Set-Up and Schematic



- | | |
|------------------|--------------------|
| a. Rubber sleeve | e. Catholyte |
| b. Anolyte | f. Cathode |
| c. Anode | g. Plastic support |
| d. Specimen | h. Plastic box |

Figure 2-13: RMT Set-Up and Schematic

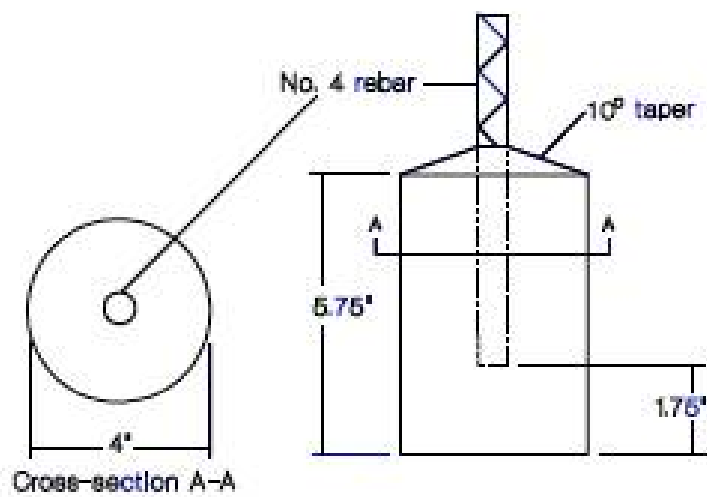
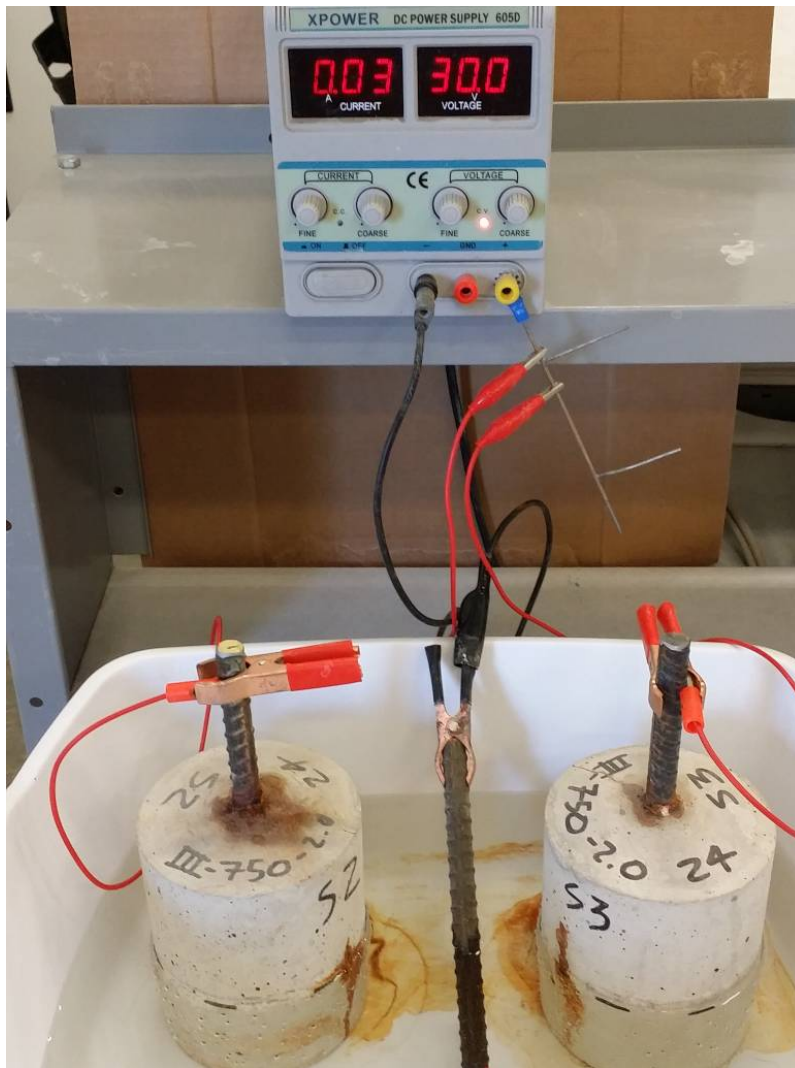

Figure 2-14: Corrosion Set-Up and Schematic

2.4.3.4 Durability Properties

To evaluate the durability properties of the studied high early-age strength concretes, the resistance to abrasion and freeze/thaw with de-icing salt tests were conducted.

2.4.3.4.1 Abrasion Resistance

Resistance to wear of the studied high early-age strength concretes were evaluated in accordance to ASTM C779, Procedure A, Ball Bearings. This test method was selected as it best simulates rolling traffic and the severe wearing found in industrial and commercial applications, as well as highway pavements exposed to traffic wear from vehicles having tires equipped with snow chains or studs. Two 152 mm x 152 mm x 152 mm (6 in. x 6 in. x 6 in.) cube-shaped samples for each curing type were used to obtain the wear depth. The testing machine used for this study is shown in Figure 2-15. The critical apparatus components to perform this test were:

- Machine was a modified Dymodrill operating at 1000 RPM
- The shaft was one-piece machined aluminum
- The shaft was hollow to allow flow of air and water
- The bearing head was designed so that the water and air can flow from the hollow center out – cleaning the “abrasion path” as it exits
- The bearing head was attached to the shaft by means of a rubber flange and spray adhesive – this also helped to reduce vibration
- The bearing head contained a thrust bearing and twelve 12.7 mm (½ in.) chrome ball bearings
- The twelve chrome ball bearings were the only part in contact with test sample
- The total load transferred through the ball bearings was 37.6 kg (82.88 lb.)
- The ball bearings started at a diameter of 12.7 mm (½ in.), and were replaced when worn down to 12.5 mm (0.49 in.)
- The air compressor output was set to 0.069 MPa (10 psi)

- The water was regular tap water at laboratory temperature, the container was a standard 5-gallon bucket mounted such that the height of the bucket produced 1,143 mm (45 in.) of head pressure
- The water output was gravity feed at a rate of 2.25-3.0 L / 20 min. test (0.6-0.8 gal/20 min. test)
- The water and air were turned on prior to the start of testing.
- The gauge interval was 0.0025 mm (9.84×10^{-5} in.)
- The test was conducted for 20 minutes and 30 seconds while taking readings every 30 seconds, or until an abrasion depth reached 3.0 mm (0.113 in.)



Figure 2-15: Abrasion Resistance Testing Machine

2.4.3.4.2 Resistance to Freezing and Thawing

Resistance to freezing and thawing of high early-age strength concretes were evaluated in accordance to ASTM C672 using cylindrical specimens mm x mm (in x in). Four samples per curing type were made, to determine the average mass loss per freezing and thawing cycle.

To start a four-day testing cycle, the samples were soaked in a 3% salt water solution for 48 hours prior to placing into a freezer for 48 hours. The first 24 hours of soaking took place on a shelf in the laboratory. The second day of soaking took place in the pre-cooler which was set to $0^{\circ} \pm 1^{\circ} \text{ C}$ ($32^{\circ} \pm 1.8^{\circ} \text{ F}$). The purpose of the pre-cooling was to smooth out the freezing period during the phase change by allowing the internal heat energy of the sample to release prior to freezing. Without this pre-cooling, there was a temperature spike of approximately 2.8° C (5° F) that occurred just after the start of the phase change (-2.78° C or 27° F for 3% salt water solutions). This was due to the rapid release of heat energy by the sample into the water. This spike in temperature would occur over a 15-20 minute period, but it would take approximately 12 hours for the temperature to lower back down and for the phase change to finish.

After the samples had been in the pre-cooler for 24 hours, they were moved into the freezer with the cooling rate set to reach $-14.4^{\circ} \pm 1^{\circ} \text{ C}$ ($6^{\circ} \pm 1.8^{\circ} \text{ F}$) at an elapsed time of 24 hours. Then freezer cooling rate was reset to maintain the temperature for the next 24 hours. At the end of the freezing cycle, samples were removed and placed outside at room temperature for the first 24 hours of thawing cycle.

Figure 2-16 shows the typical trend for temperature as a function of freezing and thawing cycles. The spike at 24 hours is due to moving the samples from the cooler to the freezer. Figures 2-17 and 2-18 show the pre-cooler and the freezer respectively.

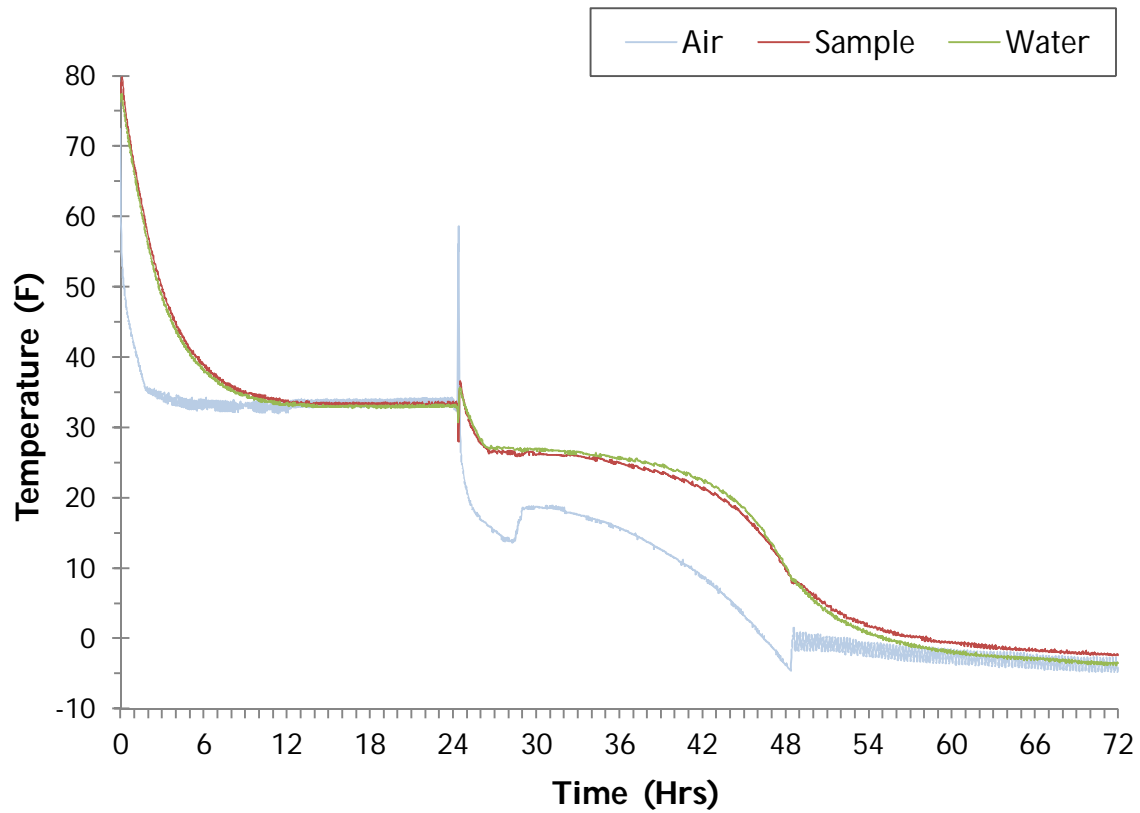

Figure 2-16: Typical Trend for the Cooling of the Freeze/Thaw Samples



Figure 2-17: Cooler Used for Pre-Cooling of Freeze/Thaw Samples



Figure 2-18: Freezer Used to Freeze the Freeze/Thaw Samples

2.5 Summary of Experimental Program

Table 2-4 shows the high early-age strength concrete testing program with respect to test performed, curing ages investigated for each test, and air-entrainment.

Table 2-4: Experimental Program

Properties		Test	Without Air-Entrainment	With Air-Entrainment
Fresh	Flow		✓	✓
	Setting Time		✓	
	Air Content		✓	✓
	Unit Weight		✓	✓
	Hydration Heat		✓	✓
Mechanical	Compression		OT - 24H - 28D	OT - 24H - 28D
	Flexure		OT - 24H - 28D	
Volume Change	Dry Shrinkage		OT - 24H - 28D	
Transport	Absorption		OT - 24H - 28D	OT - 24H - 28D
	Water Permeability		24H - 28D	
	RCPT		24H - 28D	24H - 28D
	RMT		24H - 28D	24H - 28D
	Corrosion of Steel		24H - 28D	
Durability	Abrasion Resistance		24H - 28D	
	Freeze / Thaw w/ Salt			24H - 28D

Chapter 3 Fresh Properties of High Early-Age Strength Concretes

Chapter 3 presents the results of the fresh properties for the studied high early-age strength concretes. The required HRWR to maintain a uniform workability, workability, time of setting, air content and unit weight, and heat of hydration are discussed for concretes made with different cement factors of ASTM Types V and III Portland cement, Rapid Set, and blended cements.

3.1 Required HRWR to Maintain Uniform Workability

Table 3-1 presents the results of the required HRWR to attain uniform workability for the studied high early-age strength concretes. In order to achieve target workability of $102 \pm 25\text{mm}$ (4 ± 1 in.), the amount of HRWR varied amongst the studied concrete while remaining below the maximum allowable dosage of 3.24 kg/m^3 (12 fl. Oz./100 lb. cement wt.) recommended by the manufacturer.

When 386 kg/m^3 (650 lb/yd^3) cement factor was used, the amount of HRWR remained the same for both air-entrained and non-air-entrained concretes. When using air-entrainment with the other three Type V cement factors, a reduction of HRWR was needed in order to maintain a uniform workability.

For high early-age strength Type III cement concrete, the higher Blain Fineness combined with the low water-to-cement ratio (w/c) of 0.275 resulted in having to exceed the HRWR manufacturer's recommended dosage in order to maintain the target workability. Subsequently, the w/c for Type III Portland cement was increased to 0.35.

The demand for HRWR decreased with increasing Type III cement factor and use of air-entraining admixture.

For the Rapid Set cement concrete, the manufacturer recommends a minimum w/c of 0.40 due to its high demand for mixing water. As shown in Table 3-1, an increase in HRWR was needed with increasing Rapid Set cement factor. A decrease is shown when comparing air-entrained with non-air-entrained concrete made with a similar cement factor.

In addition to the above-mentioned three cement types, two blended cements were also used. Both the 50/50 cement (50% Type V and 50% Rapid Set) and the 75/25 cement (75% Type V and 25% Rapid Set) produced slump values of 165-191 mm (6½ – 7½ in.) for both air-entrained and non-air-entrained concrete. This slump was accepted as it provided adequate working time required when using Rapid Set cement. However, the increased working time delayed setting and hardening of Type V cement.

3.2 Workability

Table 3-1 also documents the slump values for the studied high early-age strength concretes. It was observed, through physical batching and noting the time, that the window of workability for these concretes was approximately 13 ± 1 minutes. This period reflects the available time to properly cast and densify the studied concretes. As can be seen, the target workability (slump value) was kept fairly uniform for each cement type and selected water-to-cement ratio used in this study. As alluded to in Section 3.1, the amount of HRWR varied in order to attain the target workability.

Table 3-1: Water-to-Cement Ratio, HRWR Used, and Resulting Slump

Mixture ID	w/c	HRWR Max. Limit per batch kg/m ³ (lb/yd ³)	Amount HRWR Used kg/m ³ (lb/yd ³)	Slump mm (in.)
V-650-2.0	0.275	3.24 (5.46)	3.24 (5.46)	89-114 (3½ - 4½)
V-750-2.0	0.275	3.74 (6.30)	2.91 (4.90)	89-114 (3½ - 4½)
V-850-2.0	0.275	4.23 (7.13)	2.47 (4.16)	89-114 (3½ - 4½)
V-950-2.0	0.275	4.75 (8.01)	2.03 (3.42)	89-114 (3½ - 4½)
AE-V-650-2.0	0.275	3.24 (5.46)	3.24 (5.46)	102-127 (4 - 5)
AE-V-750-2.0	0.275	3.74 (6.30)	2.80 (4.72)	102-127 (4 - 5)
AE-V-850-2.0	0.275	4.23 (7.13)	2.14 (3.61)	102-127 (4 - 5)
AE-V-950-2.0	0.275	4.75 (8.01)	1.87 (3.15)	102-127 (4 - 5)
V-650-2.8	0.275	3.24 (5.46)	3.24 (5.46)	89-114 (3½ - 4½)
V-850-2.8	0.275	4.23 (7.13)	2.46 (4.45)	89-114 (3½ - 4½)
AE-V-650-2.8	0.275	3.24 (5.46)	3.24 (5.46)	102-127 (4 - 5)
AE-V-850-2.8	0.275	4.23 (7.13)	2.42 (4.08)	102-127 (4 - 5)
HW-V-650-2.0	0.275	3.24 (5.46)	3.24 (5.46)	89-114 (3½ - 4½)
III-550-2.0	0.35	2.75 (4.64)	2.20 (3.71)	114-140 (4½ - 5½)
III-650-2.0	0.35	3.24 (5.46)	1.87 (3.15)	114-140 (4½ - 5½)
III-750-2.0	0.35	3.74 (6.30)	1.65 (2.78)	114-140 (4½ - 5½)
AE-III-550-2.0	0.35	2.75 (4.64)	2.14 (3.61)	127-152 (5 - 6)
AE-III-650-2.0	0.35	3.24 (5.46)	1.65 (2.78)	127-152 (5 - 6)
AE-III-750-2.0	0.35	3.74 (6.30)	1.37 (2.31)	127-152 (5 - 6)
RS-550	0.40	2.75 (4.64)	1.87 (3.15)	178-203 (7 - 8)
RS-650	0.40	3.24 (5.46)	2.20 (3.71)	178-203 (7 - 8)
AE-RS-550	0.40	2.75 (4.64)	1.70 (2.87)	178-203 (7 - 8)
AE-RS-650	0.40	3.24 (5.46)	1.81 (3.05)	178-203 (7 - 8)
VRS-650-50/50	0.3375	3.24 (5.46)	2.75 (4.64)	165-191 (6½ - 7½)
VRS-650-75/25	0.3063	3.24 (5.46)	3.19 (5.38)	165-191 (6½ - 7½)
AE-VRS-650-50/50	0.3375	3.24 (5.46)	2.53 (4.26)	165-191 (6½ - 7½)
AE-VRS-650-75/25	0.3063	3.24 (5.46)	3.08 (5.19)	165-191 (6½ - 7½)

3.3 Setting

Table 3-2 and Figure 3-1 presents the initial and final setting times of the studied non-air-entrained high early-age strength concretes. Type III and Type V Portland cements with 2.0% accelerator were evaluated for setting times. Type V Portland cement with 2.8% accelerator was not evaluated since the manufacturer states that the accelerator does not have any influence until after final setting occurs. Therefore, it was expected

that it would produce similar results as the Type V Portland cement with 2.0% accelerator.

The initial setting of high early-age strength concrete containing Type III Portland cement remained fairly uniform around 69 minutes as the cement factor increased from 550 to 750 lb/yd³. The final setting time marginally varied from 120 to 130 minutes as the cement factor increased from 550 to 750 lb/yd³.

When Type V Portland cement was used, the initial setting time of high early-age strength concretes remained independent of cement factor at approximately 85 minutes, whereas the final setting time steadily decreased from 169 minutes for 650 lb/yd³ to 151 minutes for cement factor of 950 lb/yd³.

The reduction in setting times in Type III when compared to Type V Portland cement is due to Type III cement having an increased C₃S content and higher Blain Fineness (see Table 1-10). It is well established that an increase in water-to-cement ratio leads to an increase in setting times. Since the studied concretes made with Type III Portland cement had a higher water-to-cement ratio, it would suggest that its C₃S and Blain Fineness had greater influence on setting time than water-to-cement ratio.

high early-age strength concretes containing Rapid Set cement were not evaluated for setting times since the manufacturer assigned 20 minutes for initial setting and 30 minutes for final setting. This uniformity in setting times when Rapid Set concrete is used, including the blended cements (50/50 and 75/25), is also reflected in the results obtained for heat of hydration as discussed in Section 3.5.

Table 3-2: Initial and Final Setting Times for Type III and Type V Cement Concretes

Cement Type	Cement Factors (lb/yd ³)				
Type III	550	650	750	850	950
Initial Setting Time	68	70	68		
Final Setting Time	130	129	120		
Type V					
Initial Setting Time		87	86	84	85
Final Setting Time		167	158	154	151

Times are in minutes.

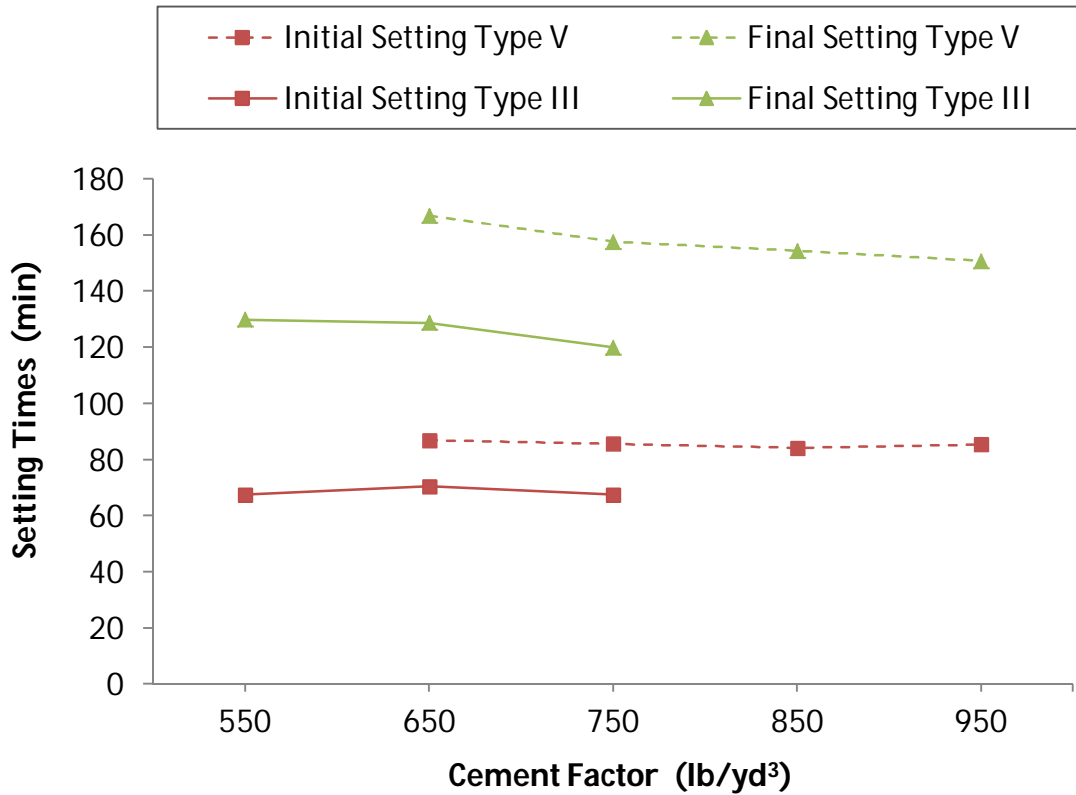

Figure 3-1: Initial and Final Setting Times for Type III and Type V

3.4 Air Content and Unit Weight

Table 3-3 presents the results of the air content for both non-air-entrained and air-entrained high early-age strength concretes. The target air content for air-entrained concretes was 6 ± 1 %. The air content of studied air-entrained concretes ranged from 5.8 to 6.8 %.

It is important to note that the concretes made with Rapid Set cement, and the two blended cements, required unusually low dosages of air-entrainment admixtures 0.055 – 0.165 L/m³ (0.01 – 0.03 gal/yd³) to achieve the targeted air-content. Figure 3-2 shows the air content of Rapid Set cement as a function of air-entraining admixture dosage for concrete containing 650 lb/yd³. The trend shows that Rapid Set cement concrete was extremely sensitive to air-entrainment.

With respect to unit weight, as shown in Table 3-3, the range for non-air-entrained concretes was 158.4 - 154.2 lb/ft³ and for air-entrained mixtures was 156.1 – 148.4 lb/ft³. It can also be seen that both entrained and non-entrained high early-age strength Type V Portland cement concretes had the highest unit weights, whereas Rapid Set cement concretes exhibited the lowest unit weights amongst the studied mixtures.

3.5 Heat of Hydration

The results of heat of hydration of the studied high early-age strength concrete are presented in Table 3-4 and Figure 3-3. Table 3-4 provides hydration temperature at opening time, as well as maximum heat of hydration and the elapsed time corresponding to peak temperature. Figure 3-3 shows the heat of hydration reached at opening time.

Table 3-3: Results for Unit Weight, Amount of Air-Entrainment Used, Change in HRWR, and Resulting Air Content

Batch	Entrapped Air Content %	Non-Air-Entrained Unit Wt. (lb/ft ³)	Air Entrainment Added L/m ³ (gal/yd ³)	HRWR Reduction kg/m ³ (lb/yd ³)	Resulting Air Content %	Entrained Unit Wt. (lb/ft ³)
V-650-2.0	2.6	158.4				
V-750-2.0						
V-850-2.0						
V-950-2.0	1.8	157.1				
AE-V-650-2.0			2.2 (0.43)	0	6.8	156.1
AE-V-750-2.0			2.5 (0.50)	0.11 (0.19)	6.4	156.2
AE-V-850-2.0			2.8 (0.57)	0.33 (0.56)	6.3	155.3
AE-V-950-2.0			3.1 (0.64)	0.16 (0.28)	5.9	155.7
V-650-2.8						
V-850-2.8						
AE-V-650-2.8			1.55 (0.31)	0	6.6	153.6
AE-V-850-2.8			1.49 (0.30)	0.22 (0.37)	6.3	150.8
HW-V-650-2.0						
III-550-2.0	2.9	156				
III-650-2.0						
III-750-2.0	3.1	156				
AE-III-550-2.0			0.8 (0.17)	0.05 (0.09)	6.7	150.4
AE-III-650-2.0			1.9 (0.39)	0.22 (0.37)	6.5	152.1
AE-III-750-2.0			2.3 (0.46)	0.27 (0.46)	6.0	153.6
RS-550	2.2	154.4				
RS-650	2.5	154.2				
AE-RS-550			0.06 (0.011)	0.16 (0.28)	5.8	151.2
AE-RS-650			0.11 (0.022)	0.38 (0.65)	6.3	148.4
VRS-650-50/50						
VRS-650-75/25						
AE-VRS-650-50/50			0.11 (0.022)	0.22 (0.37)	6.6	150
AE-VRS-650-75/25			0.17 (0.033)	0.11 (0.19)	6.6	154

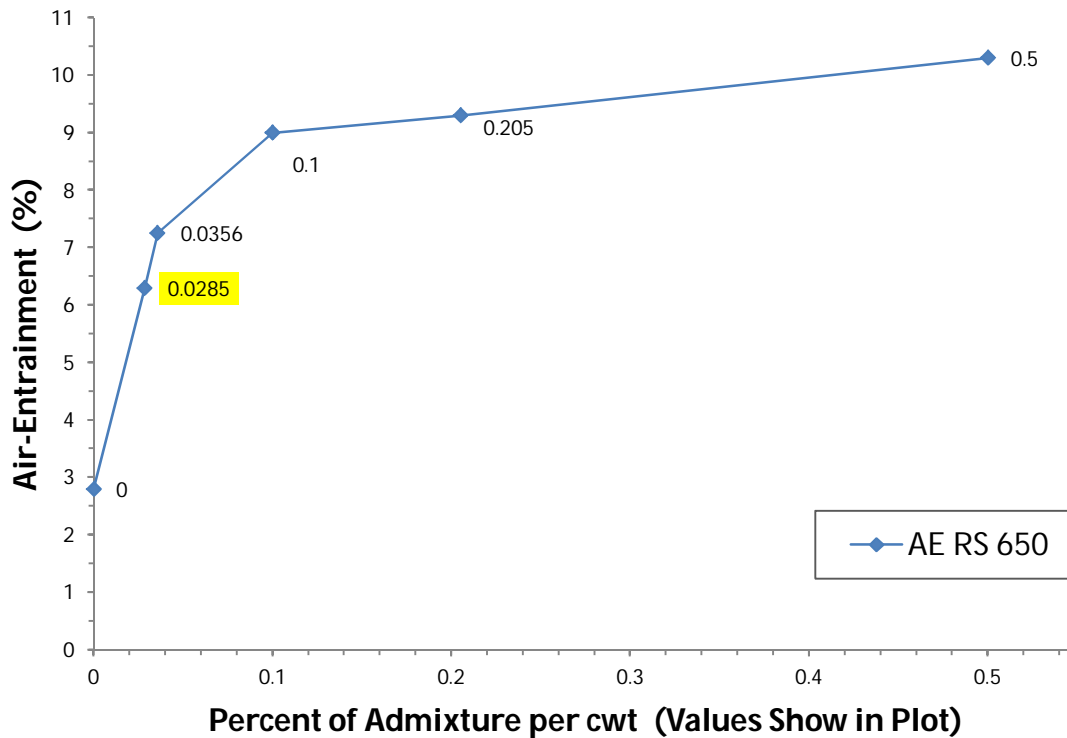

Figure 3-2: Air Content of Rapid Set concrete as a Function of Air-Entraining Admixture, Cement Factor 650 lb/yd³

3.5.1 Opening Time Heat of Hydration

As can be seen from Figure 3-3 and Table 3-4, the opening time heat of hydration increased with an increase in cement factor. For non-air-entrained Type V-2.0 cement concretes, the heat of hydration ranged from 102.1° F at 6 ½ hours to 112.2° F at 5.0 hours. It can also be seen that the Type V-2.0 cement air-entrained concrete followed a similar trend with temperatures of 101.1° F at 8 ½ hours to 118.9° F at 7 hours. For the Type V-2.8 cement concretes without air entrainment, the heat of hydration ranged from 103.5° F at 5 ½ hours to 105.4° F at 4 ½ hours. Type V-2.8 cement air-entrained concretes followed a similar trend with temperatures of 102.3° F at 7 ½ hours to 111.7° F at 6 ½ hours.

When high early-age strength Type III cement concretes without air entrainment were evaluated, heat of hydration at opening time ranged from 106.0° F at 5 ½ hours to 114.0° F at 4 ½ hours. Air-entrained Type III cement concretes displayed opening time heat of hydration temperatures of 109.5° F at 6 ½ hours to 120.1° F at 5 ½ hours.

The studied concretes containing Rapid Set cement had a constant opening time of 1 hour and showed a higher heat of hydration at opening time with increasing cement factor. The non-air-entrained mixtures showed 118.1° F to 126.4° F, whereas the air-entrained concretes produced 116.8° F to 120.9° F.

High early-age strength concretes made with blended cements of 75% Type V and 25% Rapid Set (75/25) produced a slightly higher hydration temperature of 106.9° F at opening time when compared to the concretes containing 50% Type V and 50% Rapid Set cements (50/50) which produced 105.9° F at opening time. However, their opening times were noticeably different with 75/25 concrete at 5.5 hours and only 1 hour for the 50/50 concrete. The air-entrained 50/50 blended cement concretes produced higher heat of hydration in a shorter time span with 110.5° at 1 ½ hours as compared to 106.7° at 6 ½ hours for the air-entrained concrete containing 75/25 blended cement.

Figure 3.4 and 3.5 present a typical heat of hydration over a 24-hour period for non air-entrained and air-entrained concretes, respectively, made with cement factor of 650 lb/yd³. Type III cement concrete began its main hydration phase sooner than the Type V cement mixtures and a higher temperature over the course of 24 hours. The studied concretes made with Rapid Set cement had an immediate and steep slope, indicating its main hydration phase occurred quickly and proceeded at an extremely fast pace. For the two blended cement mixtures, it can be seen that as the amount of Rapid

Set cement was decreased, the slope of the main hydration phase also decreased and the peak temperature took place at the higher elapsed time.

Table 3-4: Heat of Hydration at Opening Time and Maximum Heat of Hydration Including Elapsed Time

	Heat @ OT	Opening Time	Maximum Heat	Elapsed Time
	°F	(hrs)	°F	(hrs)
Type V-2.0				
650	102.1	6.5	103.1	7.2
AE-650	101.1	8.5	101.6	7.9
HW-650	102.4	6.5	105.0	8.1
750	105.1	6.0	108.9	7.8
AE-750	109.2	8.0	109.6	8.1
850	103.5	5.5	115.4	8.1
AE-850	113.6	7.5	114.5	8.2
950	112.2	5.0	122.4	7.7
AE-950	118.9	7.0	119.7	7.9
Type V-2.8				
650	103.5	5.5	104.5	6.3
AE-650	102.3	7.5	102.3	7.2
850	105.4	4.5	110.3	6.5
AE-850	111.7	6.5	112.1	6.8
Type III				
550	106.0	5.5	110.2	7.4
AE-550	109.5	6.5	110.9	7.5
650	111.9	5.0	117.8	7.4
AE-650	116.2	6.0	119.0	7.9
750	114.0	4.5	124.0	7.3
AE-750	120.1	5.5	124.8	7.6
RS				
550	118.1	1.0	119.8	1.5
AE-550	116.8	1.0	121.3	1.8
650	126.4	1.0	130.7	1.5
AE-650	120.9	1.0	126.0	1.6
VRS				
50/50	105.9	1.0	111.6	1.8
AE-50/50	110.5	1.5	110.9	1.6
75/25	106.9	5.5	107.0	5.5
AE-75/25	106.7	6.5	107.1	6.5

In summary, the opening time hydration temperatures for the blended cement mixtures were higher than those of Type V-2.0 and V-2.8 cement concretes, but lower than those of concrete containing 100% Rapid Set cement.

3.5.2 Maximum Heat of Hydration

The maximum hydration temperature and the elapsed time corresponding to peak temperature are given in Table 3-4 and Figure 3-6.

When examining maximum heat of hydration with respect to cement content, it is noticed that hydration temperature increased with increases in cement factor. This is explained by the increased availability of cementitious materials for hydration reaction. In addition, as cement factors exceeded 750 lb/yd³, the maximum heat of hydration of the air-entrained concretes exceeded those of the companion non-air-entrained concretes. It is suspected that the air-entrainment may have some heat retention properties. However, taking into consideration the high-low bars, the differences between non-air-entrained and air-entrained remained negligible in many cases.

For Type V-2.0 cement concretes without air-entrainment, 650 lb/yd³ cement factor had the peak temperature of 103.1° F. When cement factor was increased to for 950 lb/yd³, the peak temperature increased to 122.4° F. For the same concrete group, the addition of air-entrainment resulted in an increased heat of hydration of 18.1° F when the cement factor increased from 650 to 950 lb/yd³. An increase of accelerator admixture raised peak heat of hydration for the 650 lb/yd³ cement factor, but not for cement factor of 850 lb/yd³. With respect to non-air-entrained Type V-2.8 cement concretes, they produced hydration temperatures of 104.5° and 110.2° F for the 650 lb/yd³ and 850 lb/yd³ cement factors, respectively. Air-entrained Type V-2.8 cement concretes produced

maximum hydration heat of 102.3° F and 112.1° F for the 650 lb/yd³ and 850 lb/yd³ cement factors, respectively.

For the Type III cement concretes without air entrainment, the maximum heat ranged from 110.2° F for 550 lb/yd³ cement factor to 124.0° F for 750 lb/yd³ cement factor. It can also be seen that air-entrained Type III cement mixtures produced peak heat of hydration of 110.9° F and 124.8° F for cement factors of 550 and 750 lb/yd³, respectively.

The maximum heat of hydration increased drastically when the studied high early-age strength concretes contained Rapid Set cement. The peak hydration temperature for the non-air-entrained mixtures was 119.8° F when 550 lb/yd³ cement factor was used. It increased to 130.7° F when cement factor was increased to 650 lb/yd³. The maximum hydration temperature for air-entrained Rapid Set cement concretes containing 550 and 650 lb/yd³ cement factors was 121.3° F and 126.0° F, respectively.

When comparing blended cement concretes made with cement factor of 650 lb/yd³, heat of hydration temperatures were comparable between non-air-entrained and air-entrained mixtures. High early-age strength 50/50 blended cement concretes generated maximum temperatures of 111.6° F and 110.9° F, respectively. For high early-age strength 75/25 blended cement mixtures, the non-air-entrained concrete had a maximum hydration temperature of 107.0° F and air-entrained concrete reached a maximum hydration temperature of 107.1° F.

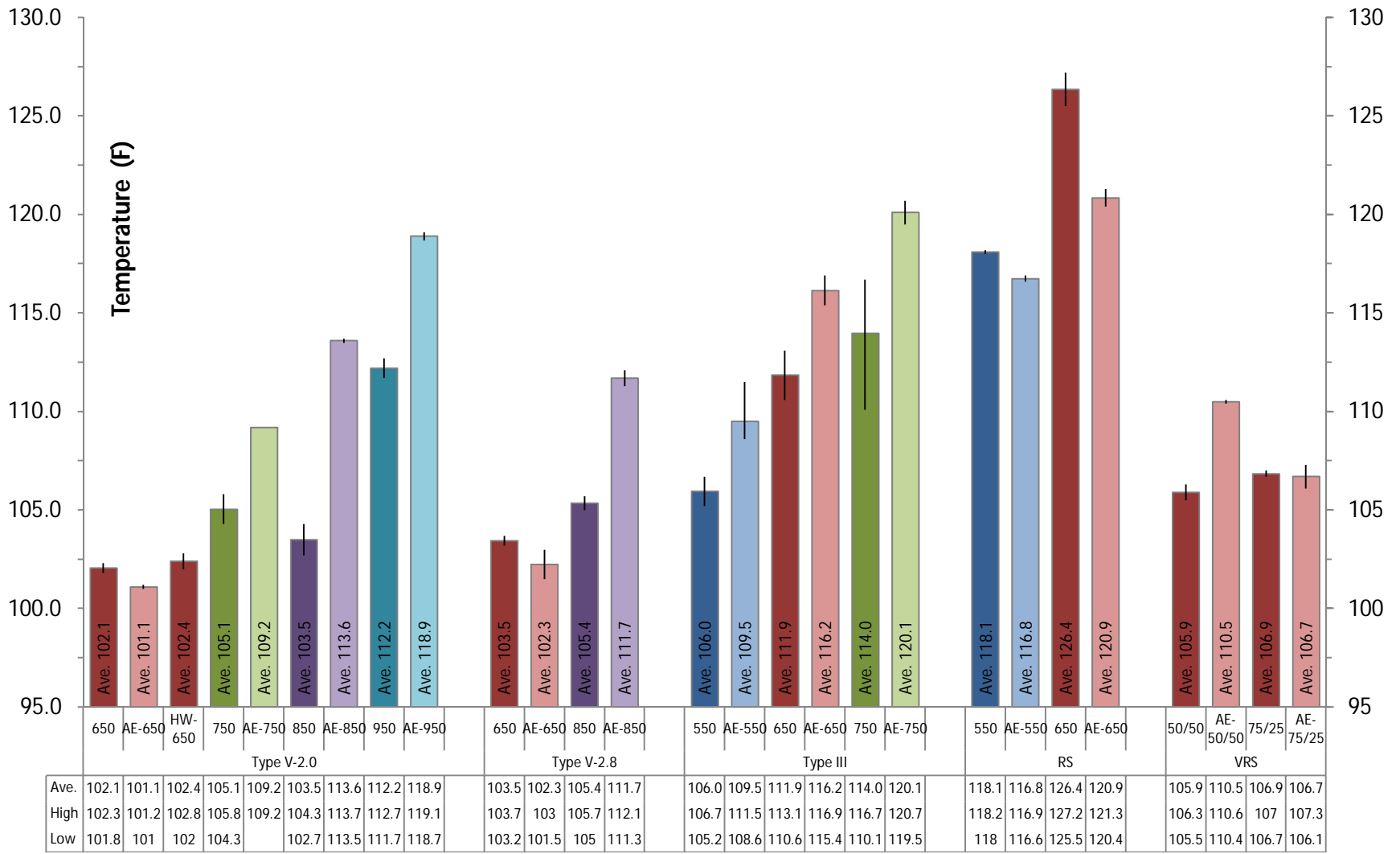

Figure 3-3: Heat of Hydration at Opening Time

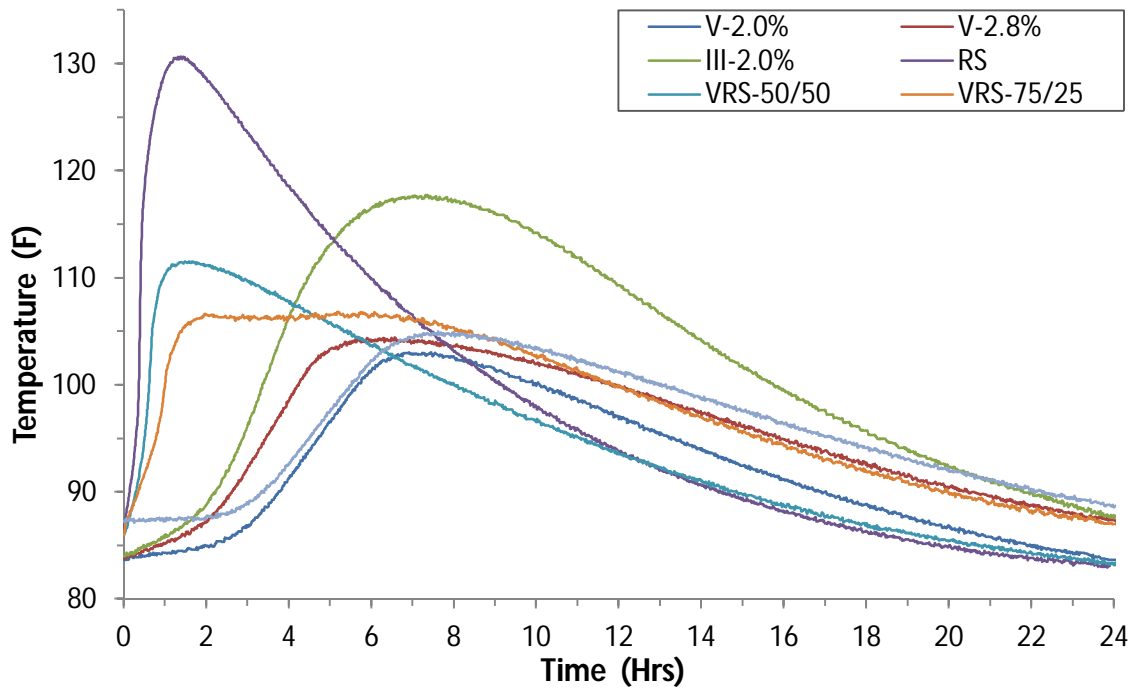

Figure 3-4: Typical Heat of Hydration Trends for Non-Air-Entrained HES Concretes (650 lb/yd³)

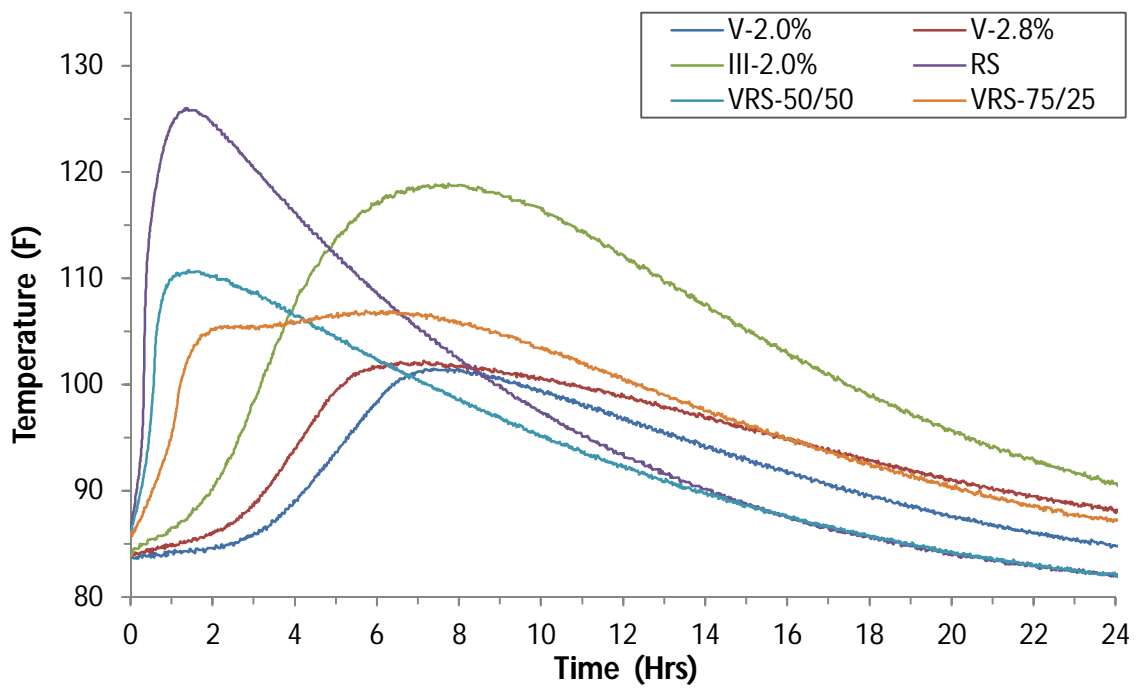

Figure 3-5: Typical Heat of Hydration Trend for Air-Entrained HES Concretes (650 lb/yd³)

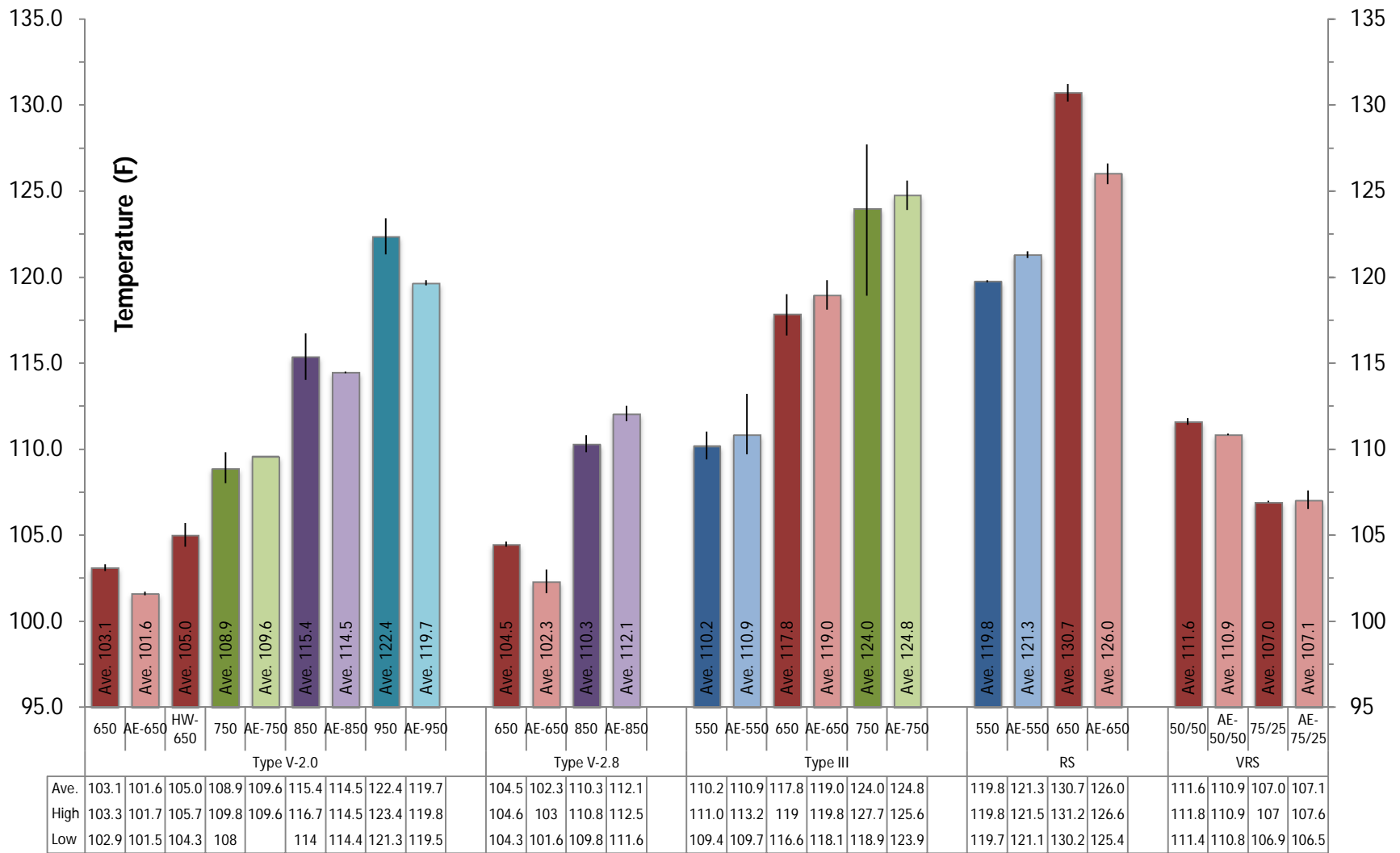

Figure 3-6: Maximum Heat of Hydration Temperature

Chapter 4 Hardened Properties of High Early-Age Strength Type V Portland Cement Concretes

4.1. Introduction

The first phase of this study dealt with evaluation of different properties of high early-age strength Type V Portland cement concretes. The five different variables considered for this phase of study were as follows:

- *Cement factor (cement content):*

Influences of four different cement contents of 650, 750, 850 and 950 lb/yd³ on properties of high early-age strength Type V cement concretes were studied.

- *Accelerator dosage:*

Effects of accelerator dosage on hardened properties of high early-age strength Type V cement concretes were studied using two different accelerator dosages of 2 and 2.8% by weight of cement.

- *Use of air-entraining admixture:*

In order to assess effects of air-entrainment on hardened properties of high early-age strength Type V cement concretes, the designed concretes were made with and without air-entraining admixture.

- *Use of hot water for mixing:*

In order to assess effects of using hot water (120 °F) for mixing on the properties of high early-age strength Type V cement concretes, one of the designed concrete

mixtures was also made using hot water (mixture with cement content of 650 lb/yd³ and accelerator dosage of 2%).

- *Curing age:*

Effects of curing age on the properties of high early-age strength Type V cement concretes were studied by testing hardened concretes at their opening time (a minimum compressive strength of 3000 psi), 24 hrs, and 28 days.

4.2. Results and Discussion

A comprehensive experimental program was devised to assess hardened properties of high early-age strength Type V cement concretes including mechanical properties (compressive and flexural strengths), transport properties (absorption, water permeability, rapid chloride penetration, and rapid chloride migration), durability properties (frost resistance, chloride induced corrosion, and resistance to wear), and dimension stability (drying shrinkage). As mentioned earlier, three testing times, depending on the property tested, were considered at opening time, 24 hrs, and 28 days.

4.2.1. Compressive Strength

Table 4.1 presents results of compressive strength test for the studied high early-age strength Type V cement concretes at different curing ages including opening time, 24 hrs and 28 days. Table 4.2 documents the opening times (time to reach a minimum compressive strength of 3000 psi) and range of compressive strengths at opening times. Effects of dominant variables on the compressive strength and opening time of the studied concretes are discussed below.

Table 4-1: Compressive Strength of Type V-HES Concretes (psi)

Mixture Identification		Testing Time		
		Opening Time	24 hrs	28 days
Type V-2.0	650	3575	8401	12068
	AE-650	3278	5372	7541
	HW-650	3343	9090	
	750	3824	8855	13257
	AE-750	3468	5438	7839
	850	4366	9401	14136
	AE-850	3719	5440	9386
	950	3470	9099	13406
Type V-2.8	AE-950	3182	5882	8751
	650	3138	9204	15073
	AE-650	3376	6180	10206
	850	3472	9981	14959
	AE-850	3790	7004	10805

* AE= Air-entrained HW= Hot water

Table 4-2: Opening Time of Type V-HES Concretes and Range of Compressive Strengths at Opening Time

Mixture Identification		Compressive Strength (psi)			Opening Time (hrs)	
		Minimum	Average	Maximum	Non Air-Entrained	Air-Entrained
Type V-2.0	650	3287	3575	3896	6.5	
	AE-650	3072	3278	3605		8.5
	HW-650	3112	3343	3536	6.5	
	750	3578	3824	4175	6	
	AE-750	3300	3468	3623		8
	850	3871	4366	4921	5.5	
	AE-850	3209	3719	4268		7.5
	950	3067	3470	3956	5	
Type V-2.8	AE-950	3134	3182	3230		7
	650	3008	3138	3334	5.5	
	AE-650	3123	3376	3852		7.5
	850	3239	3472	3756	4.5	
	AE-850	3057	3790	4438		6.5

* AE= Air-entrained HW= Hot water

4.2.1.1. Effects of Cement Content

Figure 4.1 presents the results for the opening time compressive strength of Type V cement concretes having different cement factors. It can be seen that as cement content was increased, the studied concretes developed their compressive strength quicker, thus opening times (time to reach the minimum compressive strength of 3000 psi) shortened.

The opening time of the studied concretes reduced by averagely half an hour for each 100 lbs increases in cement factor. In case of non air-entrained concretes having 2% accelerator, the opening times reduced from 6.5 hrs for mixtures having cement content of 650 lb/yd³ to 6, 5.5 and 5 hrs for mixtures with cement content of 750, 850 and 950 lb/yd³, respectively. Similarly, for air-entrained concretes having 2% accelerator, the opening times reduced from 8.5 hrs for mixtures with cement content of 650 lb/yd³ to 8, 7.5 and 7 hrs for concretes with cement content of 750, 850 and 950 lb/yd³, respectively. When 2.8% accelerator was used, the Type V cement non air-entrained concretes had their opening times reduced by an hour when their cement factor was increased from 650 to 850 lb/yd³.

Effect of cement factor on the 24-hr and 28-day compressive strengths of Type V cement concretes is presented in Figure 4.2. It can be seen that overall, the compressive strength increased with increases in cement content to an optimum level, after which increases of cement content didn't improve (increase) the compressive strength. On average, the 24-hr compressive strength increased marginally by 3.3, 3.1 and 2.5% when the cement factor was increased from 650 to 750, 750 to 850 and 850 to 950 lb/yd³, respectively. The 28-day compressive strengths increased by averagely 6.9 and 13.2% when the cement content was increased from 650 to 750 and 750 to 850 lb/yd³,

respectively. The 28-day compressive strength reduced by averagely 6.0% when the cement factor was increased from 850 to 950 lb/yd³.

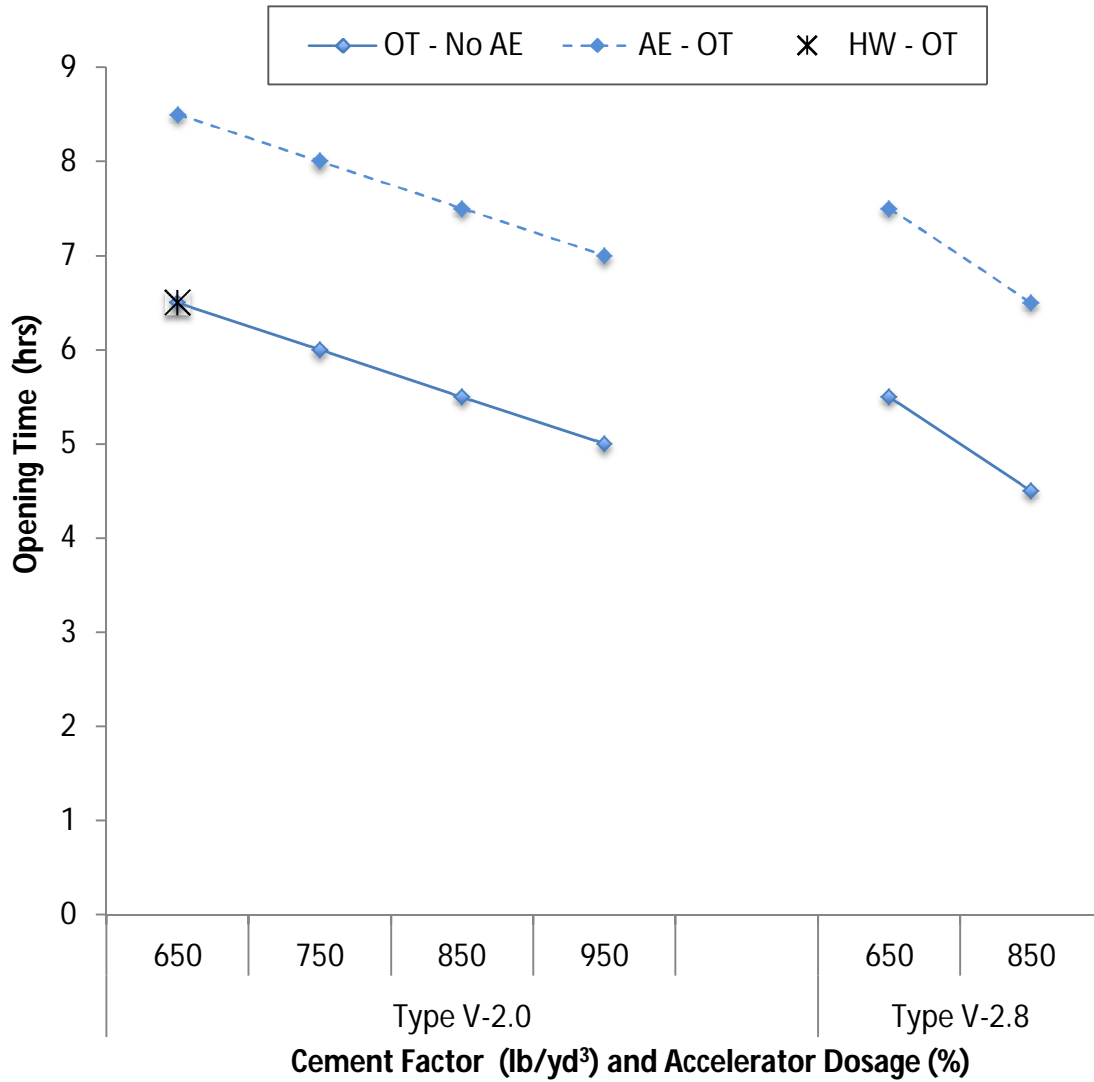

Figure 4-1: Opening Time of Type V-HES Concretes

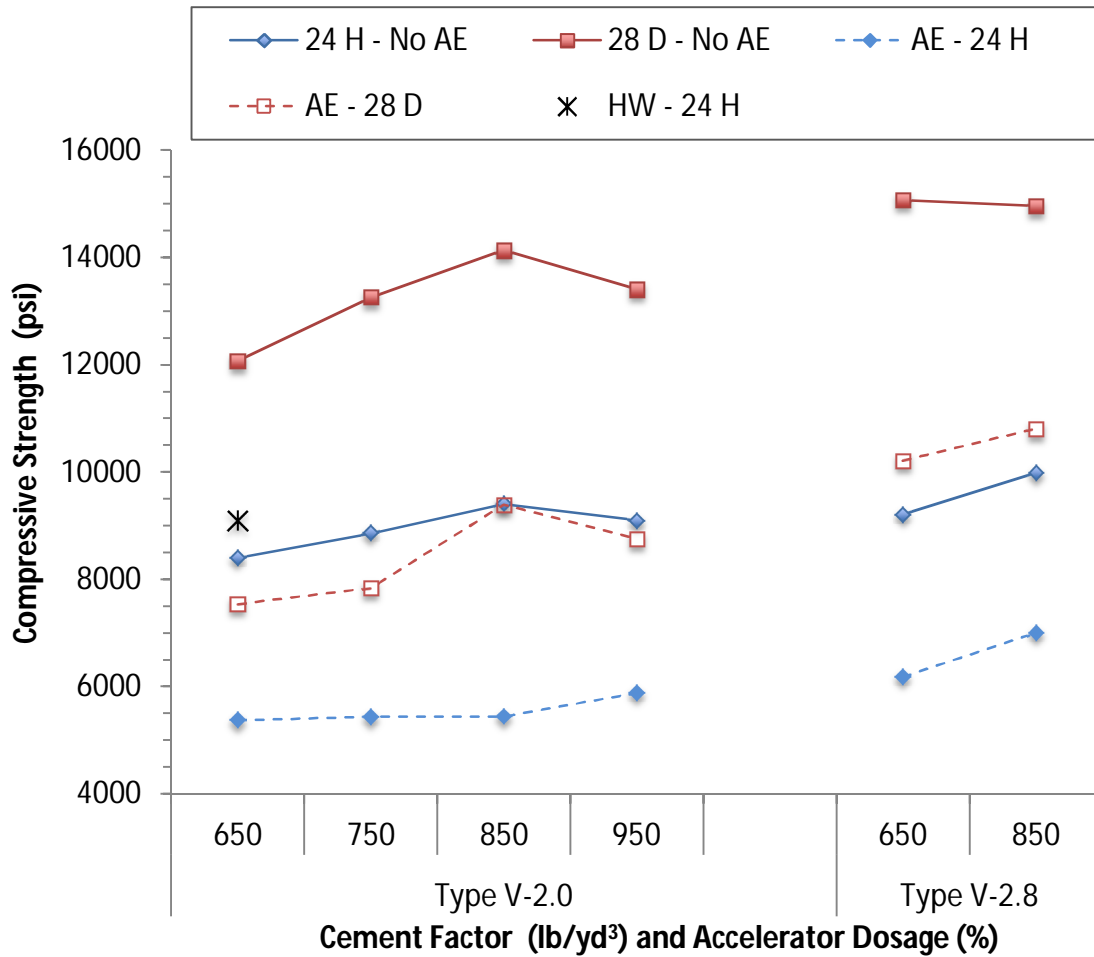

Figure 4-2: Compressive Strength of Type V-HES Concretes at 24 Hrs and 28 Days

4.2.1.2. Effects of Accelerator Dosage

Figure 4.1 and Table 4.2 also document the opening times of Type V cement concretes made with different accelerator dosages. It can be seen that the opening times of the studied concretes reduced as accelerator dosage was increased.

The opening times of the studied concretes reduced by averagely an hour when accelerator dosage was increased from 2 to 2.8%. In the case of non air-entrained concretes, increases in accelerator dosage reduced the opening times from 6.5 to 5.5 and

5.5 to 4.5 hrs for mixtures made with the cement contents of 650 and 850 lb/yd³, respectively. Similarly for air-entrained concretes, increases in accelerator dosage reduced the opening times from 8.5 to 7.5 and 7.5 to 6.5 hrs for the concretes containing cement contents of 650 and 850 lb/yd³, respectively.

Effect of accelerator dosage on the compressive strength of Type V cement concretes was also examined and the results are also shown in Figure 4.2. It can also be seen that overall, the compressive strength increased with increases in the dosage of accelerator. On average, the 24-hr and 28-day compressive strengths of non air-entrained concretes increased by 7.9 and 15.4% when accelerator dosage was increased from 2 to 2.8%, respectively. A similar increase in accelerator dosage led to 21.9 and 25.2% increases in the 24-hr and 28-day compressive strengths of air-entrained concretes, respectively.

4.2.1.3. Effects of Air-Entraining Admixture

Figure 4.1 and Table 4.2 show effects of air-entraining admixture on the opening time of Type V cement concretes. It can be seen that the opening times increased when air-entraining admixture was added to the mixtures.

The opening times of air-entrained concretes were averagely 2 hrs more than those of non air-entrained concretes. In the case of concretes with 2% accelerator, when air-entraining admixture was added to the mixtures, their opening times increased from 6.5 to 8.5, 6 to 8, 5.5 to 7.5 and 5 to 7 hrs for cement factors of 650, 750, 850 and 950 lb/yd³, respectively. Similarly, for concretes with 2.8% accelerator and cement content of

650 and 850 lb/yd³, use of air-entraining admixture increased the opening times from 5.5 to 7.5 and 4.5 to 6.5 hrs, respectively.

Figure 4.2 also presents the effect of entrained air on compressive strength of the studied concretes. It can be seen that the compressive strength significantly reduced when air-entraining admixture was added to the mixtures.

In the case of concretes made with 2% accelerator, inclusion of air-entraining admixture reduced the compressive strengths (at 24 hrs and 28 days) by averagely 36.8, 39.7, 37.9 and 35.0% for mixtures with cement factors of 650, 750, 850 and 950 lb/yd³, respectively. For concretes made with 2.8% accelerator, addition of air-entraining admixture resulted in averagely 32.6 and 28.8% reduction in the compressive strength of concretes made with cement factors of 650 and 850 lb/yd³, respectively.

4.2.1.4. Effects of Hot Water Usage

In this study, effect of using hot water (120 °F) on the compressive strength of Type V cement concrete was evaluated for one of the designed mixtures; non air-entrained Type V cement concrete having cement factor of 650 lb/yd³ and accelerator dosage of 2%. Its effects on the opening time and compressive strength are presented in Figures 4.1 and 4.2, respectively. As can be seen, use of hot water didn't improve (reduce) opening time as the opening time of the studied mixture was similar (6.5 hrs) with and without hot water. Use of hot water, instead of tap water with laboratory room temperature, resulted in nearly 6% reduction in the compressive strength at opening time. Its inclusion, however, increased the 24-hr compressive strength by nearly 8%.

4.2.1.5. Effects of Curing Age

Effect of curing age on the compressive strength of Type V cement concretes can be seen in Table 4.1 and Figures 4.1 and 4.2. Due to the use of accelerator, the studied concretes developed their compressive strengths quickly. On average, the opening time and 24-hr compressive strengths of the studied Type V cement concretes were about 33 and 66% (1/3 and 2/3) of their 28-day compressive strengths, respectively.

4.2.2. Flexural Strength

Table 4.3 presents results of flexural strength for the studied high early-age strength Type V cement concretes at different curing ages, including opening times, 24 hrs, and 28 days. These results are also shown in Figure 4.3. It can be seen that the flexural strength of the studied concretes were in the range of 580 to 880 psi at their opening times. All tested samples had flexural strengths of higher than 550 psi at their opening times.

Similar to the results of compression test, the flexural strength increased with increases in cement content to an optimum level, after which increases of the cement content resulted in reduction of flexural strength. The 24-hr flexural strength of concretes having 2% accelerator marginally increased by 3.1 and 4.0% when the cement factor was increased from 650 to 750 and 750 to 850 lb/yd³, respectively. For similar concretes, the same increases in cement content resulted in 2.3 and 2.7% increases in the 28-day flexural strengths, respectively. For these concretes, further increases in cement factor from 850 to 950 lb/yd³ reduced the 24-hr and 28-day flexural strengths by 7.1 and 3.3%, respectively. In case of concretes having 2.8% accelerator, the 24-hr flexural strength

increased by 4.4% when cement content was increased from 650 to 850 lb/yd³. The 28-day flexural strengths of these concretes were nearly similar.

The 28-day flexural strength slightly increased with increases in accelerator dosage. While increase of accelerator dosage slightly reduced the 24-hr flexural strengths by averagely 2%, the 28-day flexural strengths increased by averagely 5% using higher dosage of accelerator.

The studied concrete developed majority of their flexural strength within the first day due to use of accelerator. On average, the opening time and 24-hr flexural strengths of the studied concretes were about 44.3 and 70.2% of their 28-day flexural strengths, respectively.

Table 4-3: Flexural Strength of Type V-HES Concrete

Mixture Identification	Testing age	Flexural Strength (psi)			
		Average	Maximum	Minimum	
Type V-2.0	650	Opening time	613	656	567
		24 hr	1071	1082	1060
		28 day	1499	1557	1424
	750	Opening time	766	794	743
		24 hr	1104	1283	925
		28 day	1533	1572	1493
	850	Opening time	877	910	850
		24 hr	1148	1225	1071
		28 day	1575	1634	1516
	950	Opening time	726	731	720
		24 hr	1067	1067	1066
		28 day	1523	1646	1400
Type V-2.8	650	Opening time	578	603	549
		24 hr	1064	1148	968
		28 day	1622	1635	1608
	850	Opening time	581	598	562
		24 hr	1111	1147	1081
		28 day	1606	1693	1520

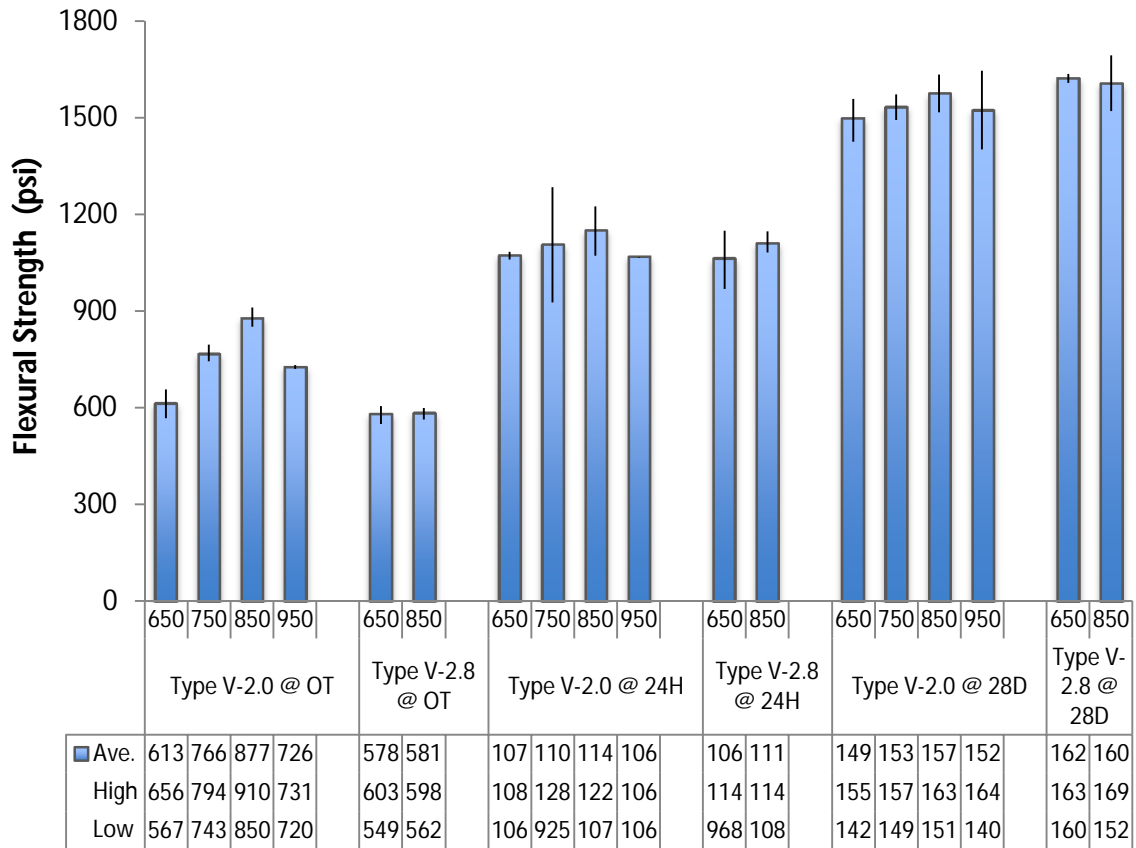

Cement Factor (lb/yd³), Accelerator Dosage (%) and Curing Age

Figure 4-3: Flexural Strength of Type V-HES Concretes

4.2.3. Absorption and Volume of Permeable Voids

Tables 4.4 and 4.5 present results of absorption test for the studied high early-age strength Type V cement concretes at different curing ages of opening times, 24 hrs and 28 days. The effects of the dominant variables on the absorption and volume of permeable voids of the studied concretes are discussed below.

Table 4-4: Results of Absorption Test for Type V-HES Concretes Containing 2% Accelerator

Mixture Identification	Testing time	Absorption After Immersion (%)	Absorption After Immersion & Boiling (%)	Volume of Permeable Voids (%)	
Type V-2.0	650	Opening time	2.61	2.88	7.27
		24 hrs	1.95	2.52	6.29
		28 days	1.05	1.31	3.31
	AE - 650	Opening time	3.35	3.80	8.61
		24 hrs	3.08	3.44	7.98
		28 days	1.77	2.03	4.63
	HW - 650	Opening time	3.44	3.61	8.88
		24 hrs	3.05	3.23	8.05
		28 days	1.57	1.71	4.17
	750	Opening time	3.08	3.18	8.36
		24 hrs	2.18	2.66	7.17
		28 days	0.89	1.32	3.33
	AE - 750	Opening time	3.76	4.41	9.72
		24 hrs	3.42	4.02	8.98
		28 days	1.84	2.12	4.73
	850	Opening time	3.61	3.94	9.46
		24 hrs	2.75	3.25	8.19
		28 days	1.02	1.31	3.16
	AE - 850	Opening time	4.36	4.80	10.81
		24 hrs	3.77	4.09	9.50
		28 days	1.77	2.02	4.80
	950	Opening time	4.21	4.57	10.83
		24 hrs	3.22	3.66	9.22
		28 days	1.18	1.40	3.35
	AE - 950	Opening time	5.24	5.22	12.34
		24 hrs	4.59	4.63	11.01
		28 days	2.06	2.30	5.29

* AE= Air-entrained

HW= Hot water

Table 4-5: Results of Absorption Test for Type V-HES Concretes containing 2.8% Accelerator

Mixture Identification	Testing time	Absorption After Immersion (%)	Absorption After Immersion & Boiling (%)	Volume of Permeable Voids (%)	
Type V-2.8	650	Opening time	3.18	3.51	8.61
		24 hrs	2.33	2.82	6.9
		28 days	1.32	1.51	3.75
	AE - 650	Opening time	3.51	3.88	8.96
		24 hrs	3.02	3.44	8.03
		28 days	1.45	1.61	3.78
	850	Opening time	4.26	4.56	11.05
		24 hrs	3.09	3.53	8.64
		28 days	1.96	2.18	5.36
	AE - 850	Opening time	4.27	4.54	10.43
		24 hrs	3.79	4.12	9.44
		28 days	1.50	1.70	4.00

* AE= Air-entrained

4.2.3.1. Effects of Cement Content

Figure 4.4 shows absorption and volume of permeable voids of high early-age strength Type V cement concretes tested at different ages of curing including opening times, 24 hrs and 28 days. It can be seen that the absorption and void contents of the studied concretes increased as cement content was increased.

For concretes made with 2% accelerator, increases in the cement factor from 650 to 750, 750 to 850 and 850 to 950 lb/yd³ increased the absorption of concretes tested at opening times by averagely 15.1, 16.6 and 18.4%, respectively. Similar increases in the cement factor increased 24-hr absorption by 11.4, 18.2 and 19.4%, and 28-day absorption by -5.6, 5.4 and 16.0%, respectively. Similar increases in the cement content increased

the opening time-void contents by 13.9, 12.2 and 14.3%, 24-hr void contents by 13.3, 10.0 and 14.2%, and 28-day void contents by 1.4, -1.8 and 8.1%, respectively.

In the case of concretes having 2.8% accelerator, increases in the cement content from 650 to 850 lb/yd³ resulted in 27.8, 29.1 and 26.0% increases in the absorption of the samples measured at opening time, 24 hrs and 28 days, respectively. The same increase in the cement content increased the void contents by averagely 22.7%.

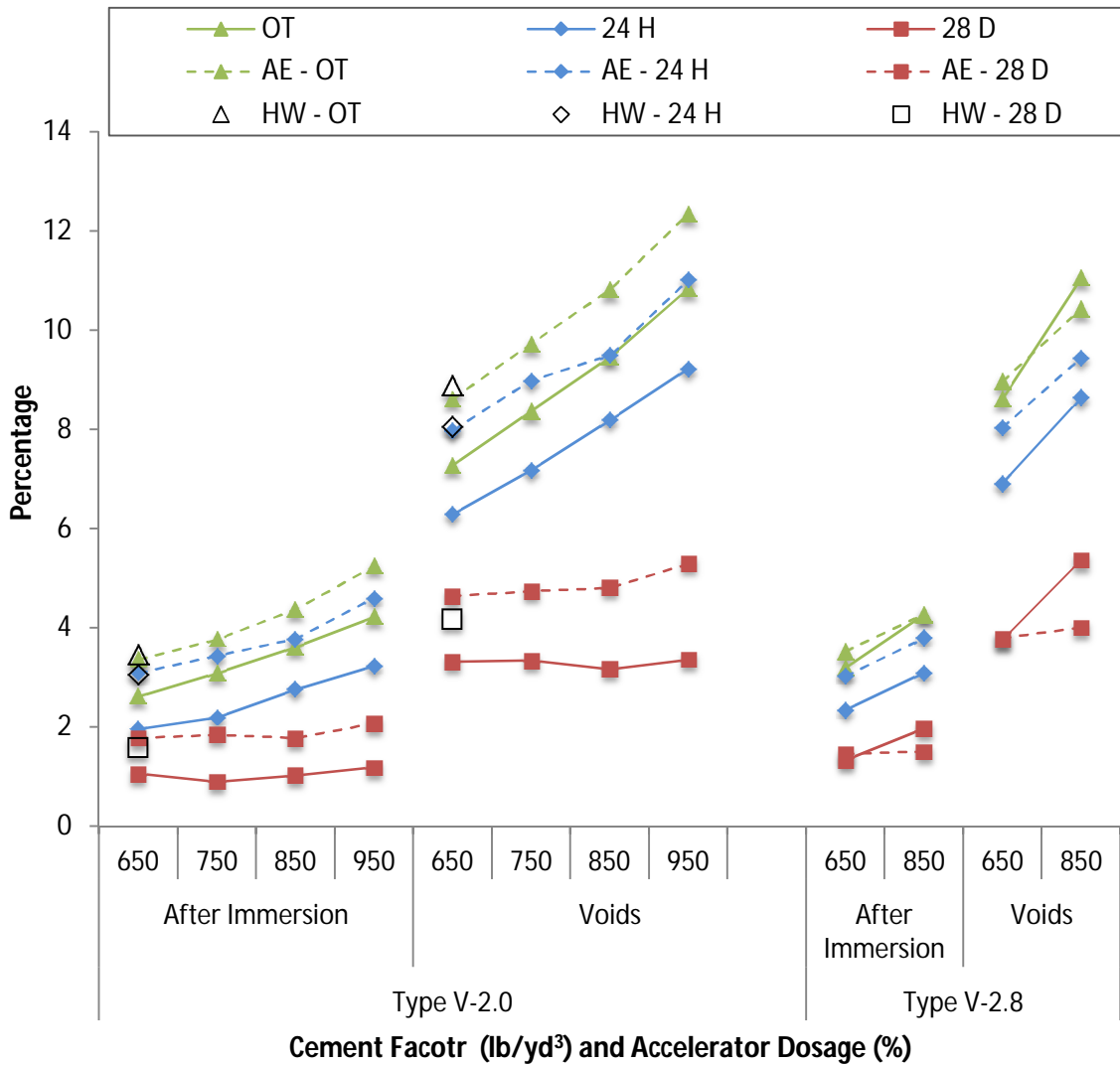

Figure 4-4: Absorption and Volume of Permeable Void for Type V-HES Concretes

4.2.3.2. Effects of Accelerator Dosage

Figure 4.4 also shows effects of accelerator dosage on the absorption and volume of permeable voids of Type V cement concretes. It can be seen that the absorption and void contents of non air-entrained concretes increased as accelerator dosage was increased. An almost opposite trend was seen for air-entrained concretes.

When accelerator dosage was increased from 2 to 2.8%, the opening time, 24-hr and 28-day void contents of non air-entrained concretes having cement content of 650 lb/yd³ increased by 18.4, 9.7 and 13.3%, respectively. For the same testing times, these increases were 16.8, 5.5 and 69.6% for non air-entrained concretes with cement content of 850 lb/yd³, respectively. When tested for the same durations, an increase in accelerator dosage (from 2 to 2.8%) increased absorption of the studied concretes made with cement content of 650 lb/yd³ by 21.8, 19.5 and 25.7%, and absorption of mixtures with cement content of 850 lb/yd³ by 18.0, 12.4 and 92.2%, respectively.

In the case of air-entrained concretes, increases in accelerator dosage didn't affect their void contents at opening time and 24 hrs. Increase of accelerator dosage, however, reduced the 28-day absorption and void contents of air-entrained concretes by averagely 16.7 and 17.5%, respectively.

4.2.3.3. Effects of Air-Entraining Admixture

Figure 4.4 also presents effects of air-entraining admixture on the absorption and volume of permeable voids of Type V cement concretes. It can be seen that the absorption and void contents significantly increased when air-entraining admixture was added to the mixtures.

In the case of concretes made with 2% accelerator, inclusion of air-entraining admixture resulted in averagely 23.9, 48.6 and 80.9% increases in the absorption of concretes tested at opening time, 24 hrs and 28 days, respectively. For similar testing days and the same concretes, the void contents increased by averagely 15.7, 21.9 and 47.9%, respectively, when air-entraining admixture was added. For concretes made with 2.8% accelerator, addition of air-entraining admixture resulted in averagely -0.8, 12.8 and -12.3% increases in void contents of concretes tested at opening time, 24 hrs and 28 days, respectively. A similar trend was seen for their absorption. At the same testing times, use of air-entraining admixture increased the absorption value by 5.3, 26.1 and -6.8%, respectively.

4.2.3.4. Effects of Hot Water Usage

Effect of using hot water was investigated for one of the studied mixtures; non air-entrained Type V cement concrete having cement factor of 650 lb/yd³ and accelerator dosage of 2%. Its effects on the absorption and void contents are presented in Figure 4.4. As can be seen, use of hot water increased the absorption and void contents of the studied concretes. For the samples tested at opening time, 24 hrs and 28 days, use of hot water increased absorption by 31.8, 56.4 and 49.5%, and void contents by 22.1, 28.0 and 26.0%, respectively.

4.2.3.5. Effects of Curing Age

Effects of curing age on the absorption and void contents of the studied concretes are also shown in Figure 4.4. It can be seen that the absorption and void contents reduced as the curing age increased. On average, the absorption reduced by 18.1 and 51.5% when curing age was extended from opening time (a few hours) to 24 hrs and 24 hrs to 28 days,

respectively. For similar extensions of curing age, the void contents reduced by averagely 12.7 and 50.7%, respectively.

4.2.4. Rapid Chloride Penetration Test

Table 4.6 and Figure 4.5 present results of rapid chloride penetration test (RCPT) for the studied high early-age strength Type V cement concretes tested at two curing ages of 24 hrs and 28 days. The effects of dominant variables on the RCPT passing charges are discussed below.

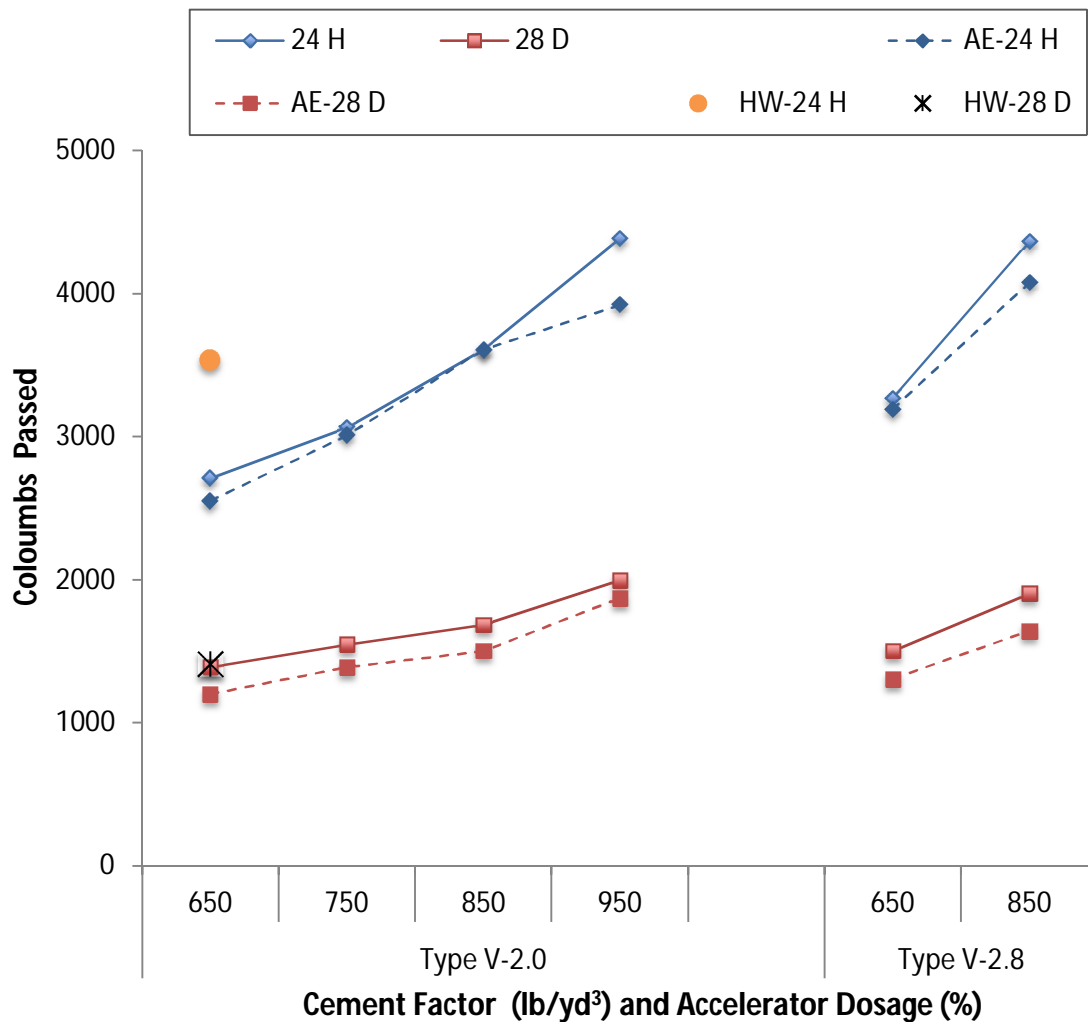

Figure 4-5: Passing Charges of Type V-HES Concretes

Table 4-6: Passing Charges of Type V-HES Concretes

Mixture Identification	Testing Time	Passing Charges (Coulombs)			
		Average	Maximum	Minimum	
Type V-2.0	650	24 hrs	2709	2898	2464
		28 days	1389	1685	1122
	AE - 650	24 hrs	2552	2992	2163
		28 days	1199	1340	1014
	HW - 650	24 hrs	3536	4007	2484
		28 days	1408	1618	1193
	750	24 hrs	3064	3267	2904
		28 days	1547	1775	1351
	AE - 750	24 hrs	3009	3548	2637
		28 days	1387	1759	1092
	850	24 hrs	3606	3863	3183
		28 days	1685	1724	1625
	AE - 850	24 hrs	3606	3745	3376
		28 days	1501	1843	1219
	950	24 hrs	4385	5324	3308
		28 days	1996	2125	1811
AE - 950	24 hrs	3921	5170	3171	
	28 days	1872	2203	1616	
Type V-2.8	650	24 hrs	3267	3888	2538
		28 days	1502	1790	1282
	AE - 650	24 hrs	3191	3458	2964
		28 days	1308	1555	975
	850	24 hrs	4368	5250	3723
		28 days	1904	2147	1624
	AE - 850	24 hrs	4082	4508	2884
		28 days	1644	1738	1468

* AE= Air-entrained HW= Hot water

4.2.4.1. Effects of Cement Content

Figure 4.5 shows effects of cement factor on the passing charges of Type V cement concretes. It can be seen that the passing charges increased as cement content was increased.

For concretes with 2% accelerator, the 24-hr passing charges increased by averagely 15.5, 18.8 and 15.2% when the cement factor was increased from 650 to 750, 750 to 850 and 850 to 950 lb/yd³, respectively. Similar increases in the cement factor increased the 28-day RCPT values of these concretes by 13.5, 8.6 and 21.6%, respectively.

In the case of concretes having 2.8% accelerator, increases in the cement content from 650 to 850 lb/yd³ resulted in averagely 30.8 and 26.2% increases in 24-hr and 28-day passing charges, respectively.

4.2.4.2. Effects of Accelerator Dosage

Figure 4.5 also shows effects of accelerator dosage on the passing charges of Type V cement concretes. It can be seen that the passing charges increased as accelerator dosage was increased.

When accelerator dosage was increased from 2 to 2.8%, the 24-hr passing charges increased by averagely 20.0%. Similar increases in accelerator dosage increased the 28-day passing charges by averagely 9.9%.

4.2.4.3. Effects of Air-Entraining Admixture

Figure 4.5 also shows effects of air-entraining admixture on RCPT values of Type V cement concretes. It can be seen that the passing charges reduced when air-entraining admixture was added to the concrete mixtures.

When concretes contained 2% accelerator, inclusion of air-entraining admixture resulted in averagely 4.5 and 10.3% reduction in the passing charges of concretes tested at 24 hrs and 28 days, respectively. For concretes made with 2.8% accelerator, addition of

air-entraining admixture reduced the 24-hr and 28-day passing charges by averagely 4.4 and 13.3%, respectively.

4.2.4.4. Effects of Hot Water Usage

As mentioned earlier, effect of using hot water was evaluated for non air-entrained Type V cement concrete having cement factor of 650 lb/yd³ and accelerator dosage of 2%. Figure 4.5 presents effect of hot water usage on the passing charges as well. It can be seen that the passing charges increased, marginally depending on concrete age, when hot water was used for mixing instead of tap water with regular laboratory room temperature. For the samples tested at 24 hrs and 28 days, hot water increased the passing charges by 30.5 and 1.4%, respectively.

4.2.4.5. Effects of Curing Age

Figure 4.5 also shows effect of curing age on RCPT results. It can be seen that the passing charges almost halved as curing age was increased from 24 hrs to 28 days. The 28-day passing charges of the studied concretes were 50 to 60% (with an average of 55%) lower than the 24-hr passing charges.

4.2.5. Rapid Chloride Migration Test

Table 4.7 and Figure 4.6 present results of rapid chloride migration test (RMT) for the studied Type V cement concretes measured for two testing ages of 24 hrs and 28 days. The effects of dominant variables on the chloride penetration depth of the studied concretes are discussed below.

Table 4-7: Chloride Penetration Depth of Type V-HES Concretes

Mixture Identification		Testing Time	Chloride Penetration Depth (in)		
			Average	Maximum	Minimum
Type V-2.0	650	24 hrs	1.52	1.55	1.50
		28 days	0.57	0.59	0.56
	AE - 650	24 hrs	1.26	1.31	1.22
		28 days	0.59	0.65	0.52
	750	24 hrs	1.23	1.23	1.23
		28 days	0.52	0.53	0.51
	AE - 750	24 hrs	1.34	1.35	1.32
		28 days	0.60	0.66	0.52
	850	24 hrs	1.14	1.19	1.09
		28 days	0.56	0.57	0.55
	AE - 850	24 hrs	1.32	1.36	1.27
		28 days	0.59	0.62	0.54
	950	24 hrs	1.09	1.14	1.07
		28 days	0.53	0.54	0.52
AE - 950	24 hrs	1.34	1.39	1.28	
	28 days	0.59	0.61	0.58	
Type V-2.8	650	24 hrs	1.43	1.47	1.38
		28 days	0.61	0.63	0.57
	AE - 650	24 hrs	1.72	1.77	1.63
		28 days	0.64	0.69	0.59
	850	24 hrs	1.27	1.29	1.25
		28 days	0.57	0.58	0.57
	AE - 850	24 hrs	1.53	1.57	1.48
		28 days	0.57	0.57	0.53

* AE= Air-entrained

HW= Hot water

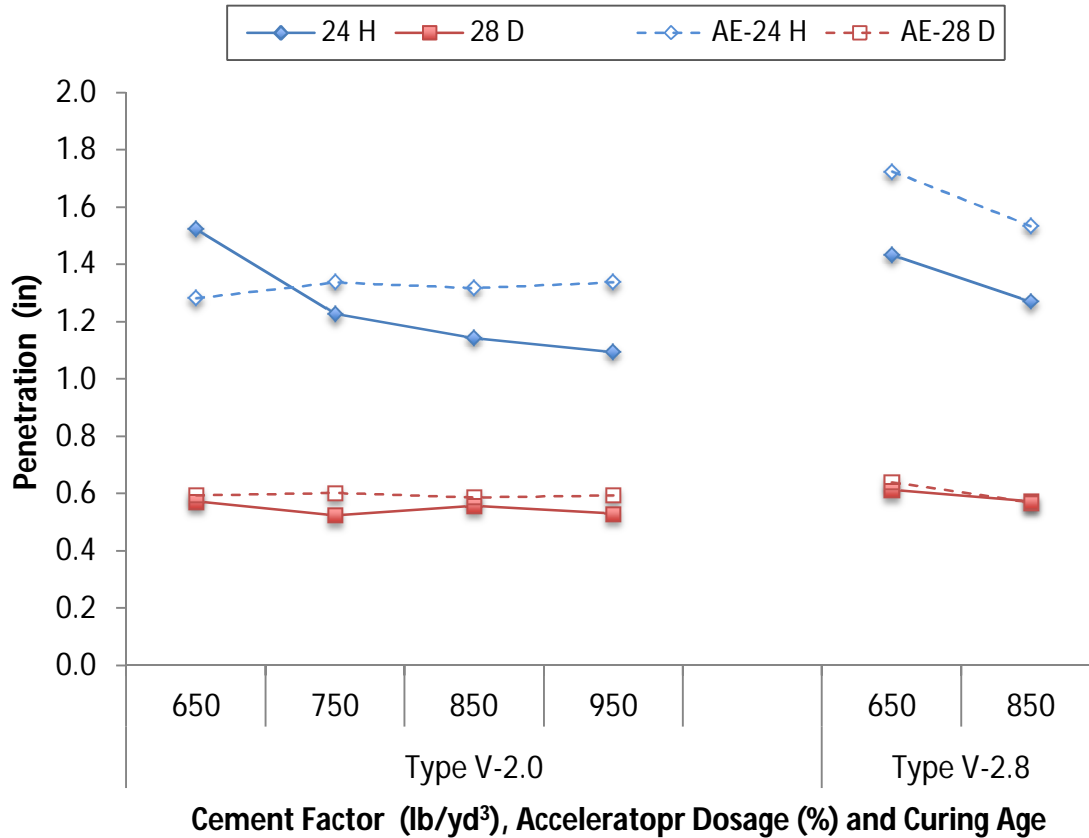

Figure 4-6: Chloride Penetration Depth of Type V-HES Concretes

4.2.5.1. Effects of Cement Content

Figure 4.6 shows effects of cement factor on the chloride penetration depth of Type V cement concretes. It can be seen that overall, the chloride penetration depth slightly reduced as cement content was increased.

For concretes with 2% accelerator, the 24-hr chloride penetration depth reduced by averagely 6.4, 4.4 and 1.4% when the cement factor was increased from 650 to 750, 750 to 850 and 850 to 950 lb/yd³, respectively. Similar increases in the cement factor decreased the 28-day chloride penetration depths of these concretes by 3.5, -3.0 and 2.7%, respectively.

In the case of concretes having 2.8% accelerator, increases in the cement content from 650 to 850 lb/yd³ resulted in averagely 11.1 and 8.7% reduction in the chloride penetration depth of concretes tested at 24 hrs and 28 days, respectively.

4.2.5.2. Effects of Accelerator Dosage

Figure 4.6 also presents effects of accelerator dosage on the chloride penetration depth of Type V cement concretes. It can be seen that overall, the chloride penetration depth increased when the dosage of accelerator was increased.

As accelerator dosage was increased from 2 to 2.8%, the 24-hr chloride penetration depths increased by averagely 14.5%. Similar increases in accelerator dosage increased the 28-day chloride penetration depths by averagely 3.5%.

4.2.5.3. Effects of Air-Entraining Admixture

Effects of air-entraining admixture on the chloride penetration depth of Type V cement concretes are also presented in Figure 4.6. It can be seen that overall, the chloride penetration depth increased as air-entraining admixture was added to the mixtures.

When concretes contained 2% accelerator, inclusion of air-entraining admixture increased the 24-hr (to a larger extent) and 28-day (to a lesser extent) chloride penetration depths by averagely 7.6 and 8.9%, respectively. For concretes made with 2.8% accelerator, these increases were averagely 20.4 and 2.5%, respectively.

4.2.5.4. Effects of Curing Age

Figure 4.6 also shows effects of curing age on the chloride penetration depth of the studied Type V cement concretes. It can be seen that the penetration depths significantly reduced as curing age was extended from 24 hrs to 28 days. The 28-day chloride penetration depths of the studied concretes were 51 to 63% (with an average of 57%) lower than the 24-hr chloride penetration depths.

4.2.6. Water Permeability

Figure 4.7 and Table 4.8 show results of water penetration depth for the studied Type V cement concretes tested at the ages of 24 hrs and 28 days. It can be seen that the depth of penetration increased as cement content and accelerator dosage were increased.

The depths of water penetration slightly increased with increases in the cement factor. In the case of concretes made with 2% accelerator, the 24-hr water penetration depths increased by 3.3, 0.8 and 3.2% when the cement content was increased from 650 to 750, 750 to 850 and 850 to 950 lb/yd³, respectively. Similar increases in the cement factor increased the 28-day water penetration depths of these concretes by 2.5, 1.6 and 6.6%, respectively. For concretes made with 2.8% accelerator, the 24-hr and 28-day water penetration depths of concretes made with cement content of 850 lb/yd³ were 8.0 and 6.5% higher than those having cement factor of 650 lb/yd³, respectively.

The depth of water penetration also increased with increases in accelerator dosage. The 24-hr water penetration depth of concretes having cement factor of 650 and 850 lb/yd³ increased by 11.2 and 15.3% when accelerator dosage was increased from 2 to

2.8%, respectively. For similar concretes, the increase of accelerator dosage increased the 28-day water penetration depths by 8.7 and 11.2%, respectively.

The depth of water penetration reduced as curing age was increased. The reductions, however, were insignificant compared to the reductions observed for the other transport properties. On average, the 28-day water penetration depths of Type V cement concretes were only about 5% lower than their 24-hr water penetration depths.

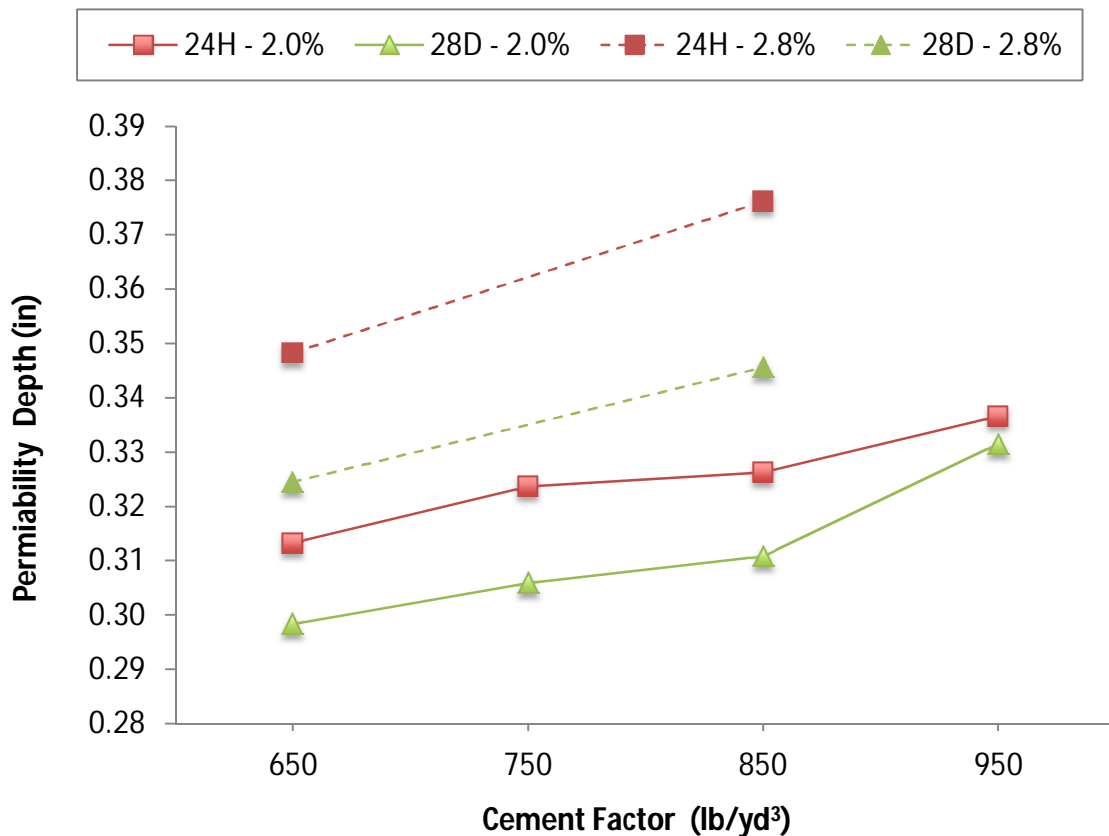

Figure 4-7: Water Penetration Depth of Type V-HES Concretes

Table 4-8: Water Penetration Depth of Type V-HES Concretes

Age	Accelerator (%)					
	2.0			2.8		
	Cement Content (lb/yd ³)			Cement Content (lb/yd ³)		
	650	750	850	950	650	850
	Water Penetration Depth (mm)					
24 hrs	7.957	8.222	8.287	8.550	8.846	9.553
28 days	7.578	7.770	7.896	8.420	8.241	8.779
	Water Penetration Depth (in)					
24 hrs	0.3133	0.3237	0.3263	0.3366	0.3483	0.3761
28 days	0.2983	0.3059	0.3109	0.3315	0.3244	0.3456

4.2.7. Drying Shrinkage

Figures 4.8 through 4.10 show drying shrinkage of Type V cement concretes for samples transferred to the shrinkage room at the ages of their opening time, 24 hrs, and 28 days, respectively. Effects of cement content, curing age, accelerator dosage, and hot water usage were studied on the drying shrinkage of Type V cement concretes, which are discussed in the following subsections.

4.2.7.1. Effects of Cement Content

Figures 4.8 through 4.10 present influences of cement factor on the drying shrinkage of Type V cement concretes. It can be seen that the drying shrinkage increased with increases in cement content.

Figure 4.11 presents the ultimate drying shrinkage of Type V cement concretes kept in shrinkage room for a year. For concretes with 2% accelerator, the drying shrinkage increased by averagely 13.1, 24.5 and 11.4% when the cement factor was increased from 650 to 750, 750 to 850 and 850 to 950 lb/yd³, respectively. These

increases were 9.6, 37.3 and 9.5% for concretes transferred to shrinkage room at their opening time; 20.6, 22.2 and 14.0% for 24-hr cured concretes; and 9.2, 14.0 and 10.6% for 28-day cured concretes, respectively. When concretes contained 2.8% accelerator, the drying shrinkage of concretes transferred to shrinkage room at the ages of opening time, 24 hrs and 28 days increased by 30.7, 33.6 and 17.3% when the cement factor was increased from 650 to 850 lb/yd³, respectively.

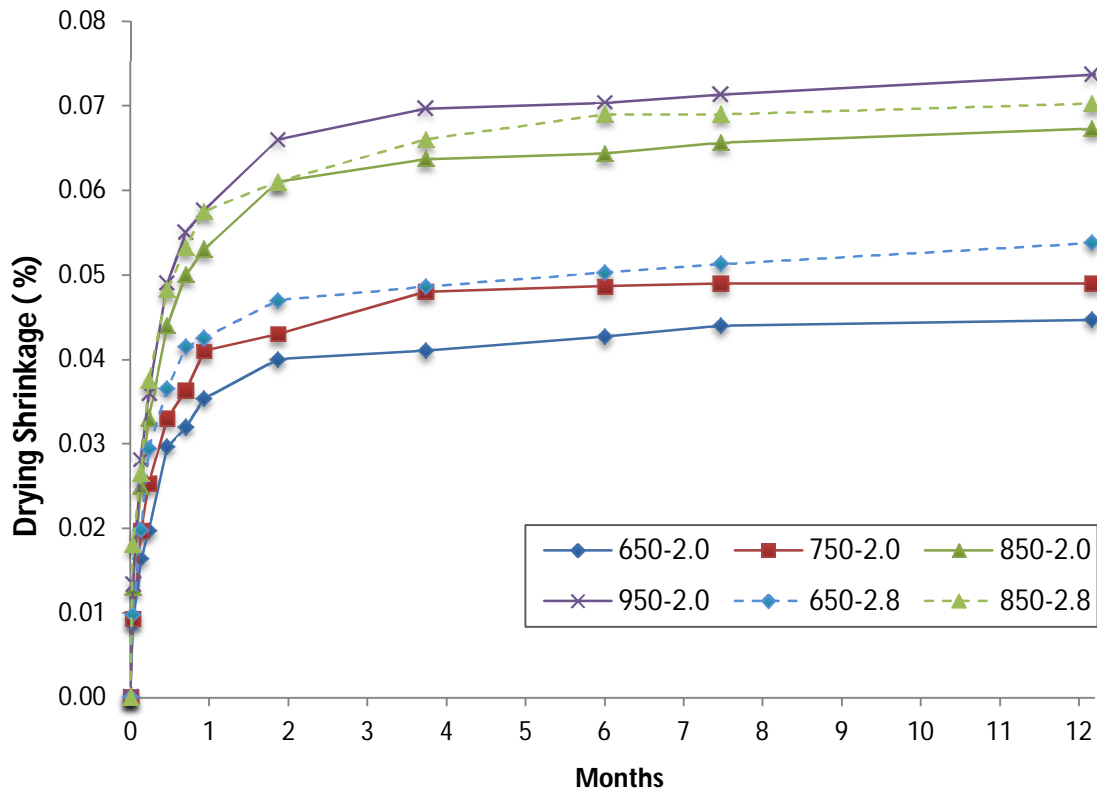

Figure 4-8: Drying Shrinkage of Type V-HES Concretes Transferred to Shrinkage Room at Opening Time

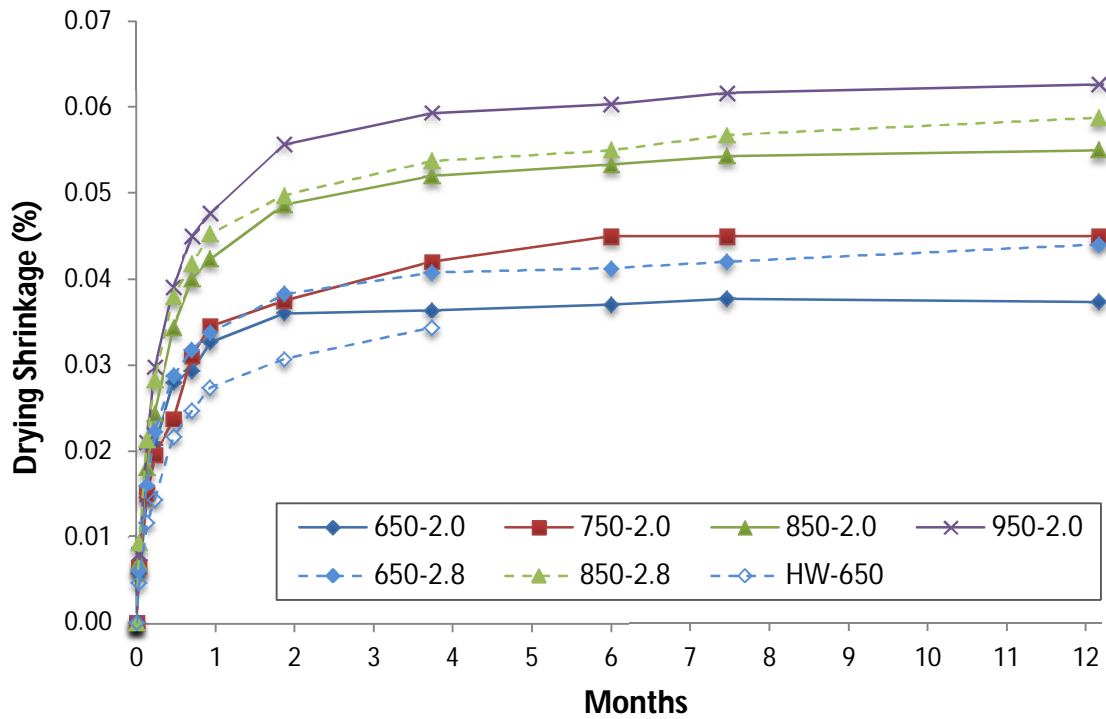

Figure 4-9: Drying Shrinkage of Type V-HES Concretes Transferred to Shrinkage Room at the Age of 24 Hrs

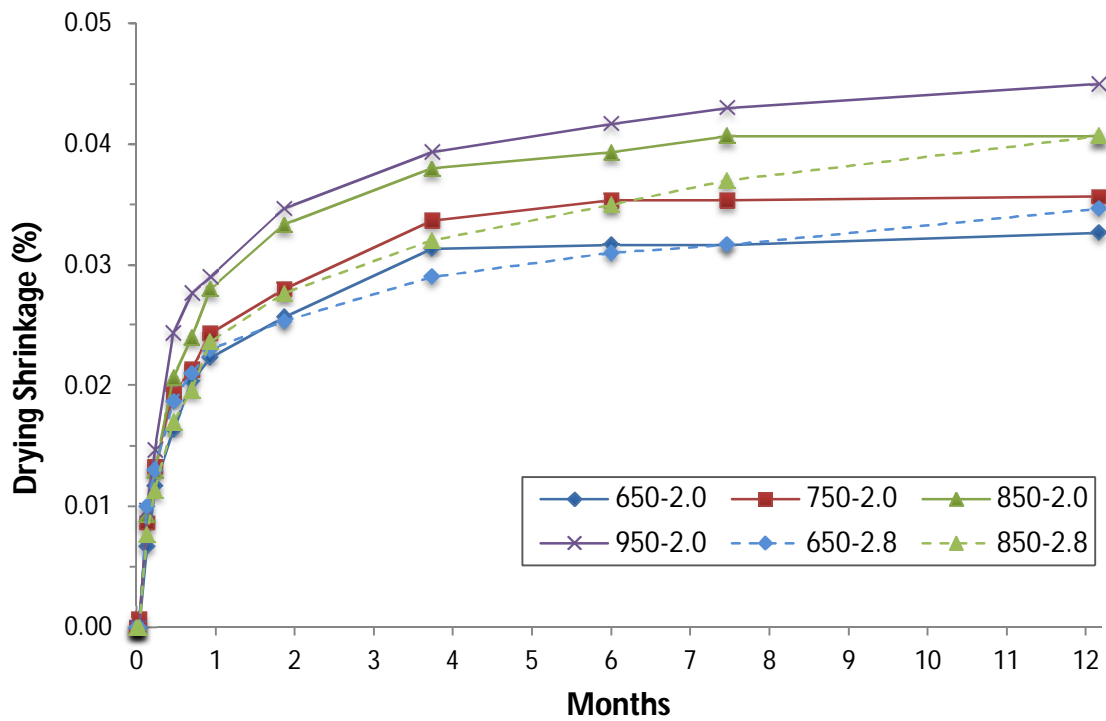

Figure 4-10: Drying Shrinkage of Type V-HES Concretes Transferred to Shrinkage Room at the Age of 28 Days

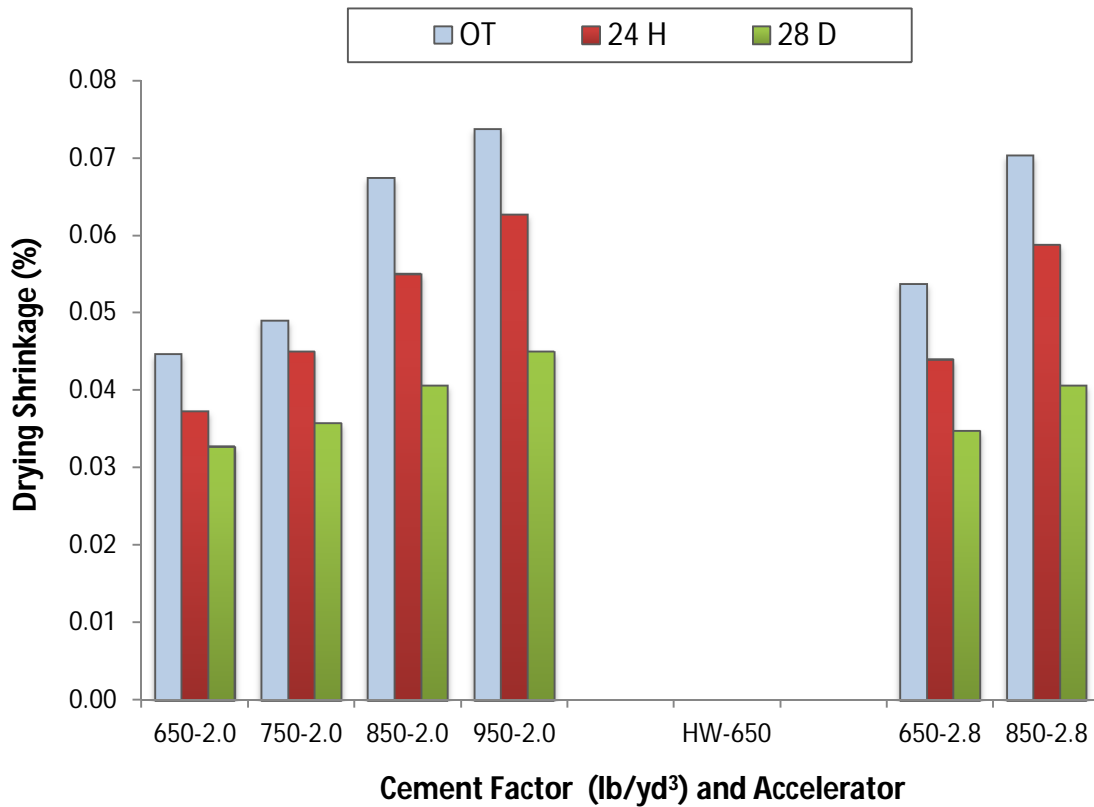

Figure 4-11: The Ultimate Shrinkage (1-Year) of Type V-HES Concretes

4.2.7.2. Effects of Accelerator Dosage

Figures 4.8 through 4.11 also present the influence of accelerator dosage on the drying shrinkage of Type V cement concretes. It can be seen that the drying shrinkage increased with increases in accelerator dosage.

When accelerator dosage was increased from 2 to 2.8%, the drying shrinkage of concretes with cement contents of 650 and 850 lb/yd³ increased by averagely 14.8 and 3.8%, respectively.

4.2.7.3. Effects of Hot Water Usage

Effect of using hot water was evaluated only on 24-hr cured concrete and the results are shown in Figure 4.9. It can be seen that the drying shrinkage reduced by about 5.5% when hot water was used for mixing instead of tap water with regular laboratory room temperature.

4.2.7.4. Effects of Curing Age

Figure 4.11 also shows effect of curing age on the ultimate drying shrinkage. It can be seen that the drying shrinkage reduced as curing age was increased. The drying shrinkage of the studied concretes reduced by averagely 15.4 and 23.2% when curing age was increased from opening time to 24 hrs and 24 hrs to 28 days, respectively.

4.2.7.5. Comparison with NDOT Specification

NDOT specification suggests a limitation on the drying shrinkage of concretes kept in shrinkage room for 28 days. This limit is 0.06% shrinkage. Figure 4.12 shows the drying shrinkage of concretes after 28 days in shrinkage room. It can be seen all the studied concretes had lower shrinkage than the NDOT prescribed specification limit.

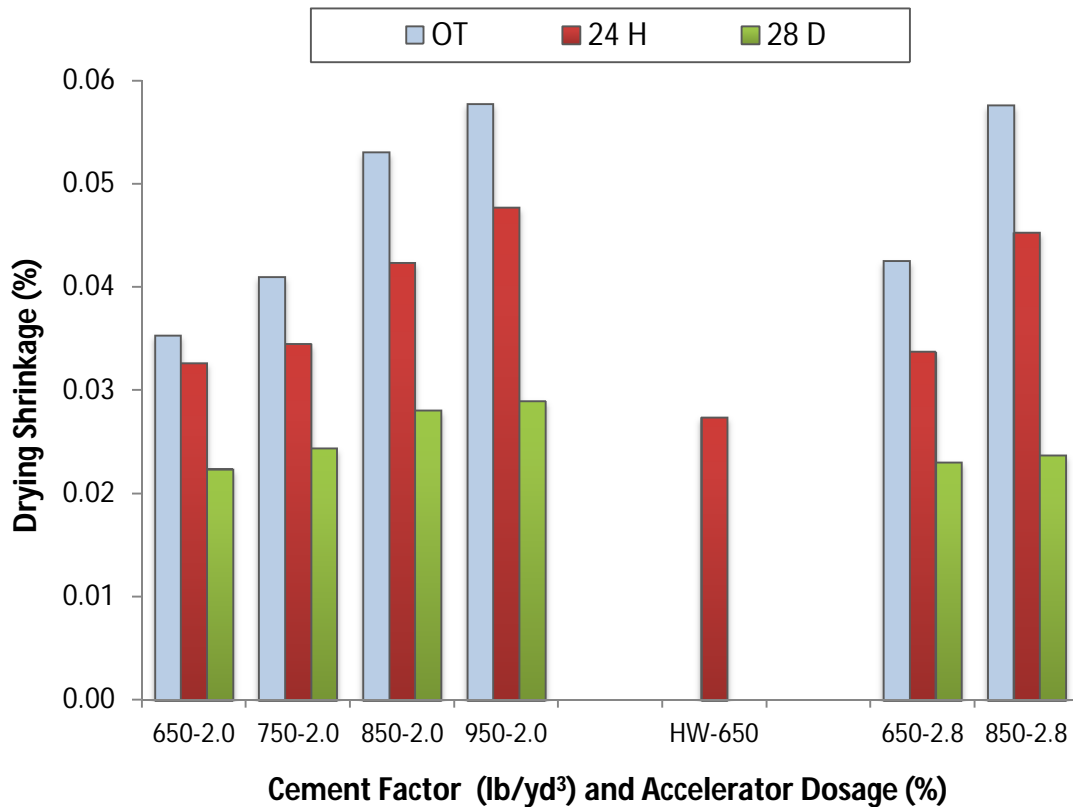

Figure 4-12: Drying Shrinkage of Type V-HES Concretes After 28 Days in Shrinkage Room

4.2.8. Corrosion Resistance

Table 4.9 and Figure 4.13 present failure time of the studied Type V cement concretes in corrosion test. It can be seen that overall the corrosion resistance improved (failure time increased) as cement content was increased. An increase of accelerator dosage had only a positive influence on the corrosion resistance of concretes made with cement factor of 650 lb/yd³.

The 24-hr corrosion resistance improved slightly with increases in the cement factor. In the case of concretes made with 2% accelerator, the 24-hr failure time increased by 13.0 and 3.8% when the cement content was increased from 650 to 750 and 750 to

850 lb/yd³, respectively. Similar increases in the cement factor increased the 28-day failure time of these concretes by 54.7 and 34.1%, respectively. Further increases in the cement content from 850 to 950 lb/yd³ had no effect on 24-hr failure time and a negative effect on the 28-day failure time (16.4% reduction). For concretes made with 2.8% accelerator, increases in cement content from 650 to 850 lb/yd³ increased the 24-hr and 28-day failure times by 3.8 and 4.2%, respectively.

Increasing accelerator dosage had a positive influence on the failure time of concrete with cement factor of 650 lb/yd³, whereas it had a negative effect on corrosion resistance of concrete having cement factor of 850 lb/yd³. The 24-hr and 28-day failure time of concretes with cement content of 650 lb/yd³ increased by 13 and 81% when accelerator dosage was increased from 2 to 2.8%, respectively. A similar increase in accelerator dosage reduced the 28-day failure time of concretes with cement content of 850 lb/yd³ by nearly 9%.

Table 4-9: Time to Failure for Type V-HES Concretes in Corrosion Test

Mixture Identification	Curing Age	Failure Time (days)	
Type V-2.0	650	24 hrs	5.75
		28 days	13.25
	750	24 hrs	6.5
		28 days	20.5
	850	24 hrs	6.75
		28 days	27.5
	950	24 hrs	6.75
		28 days	23
Type V-2.8	650	24 hrs	6.5
		28 days	24.0
	850	24 hrs	6.75
		28 days	25.0

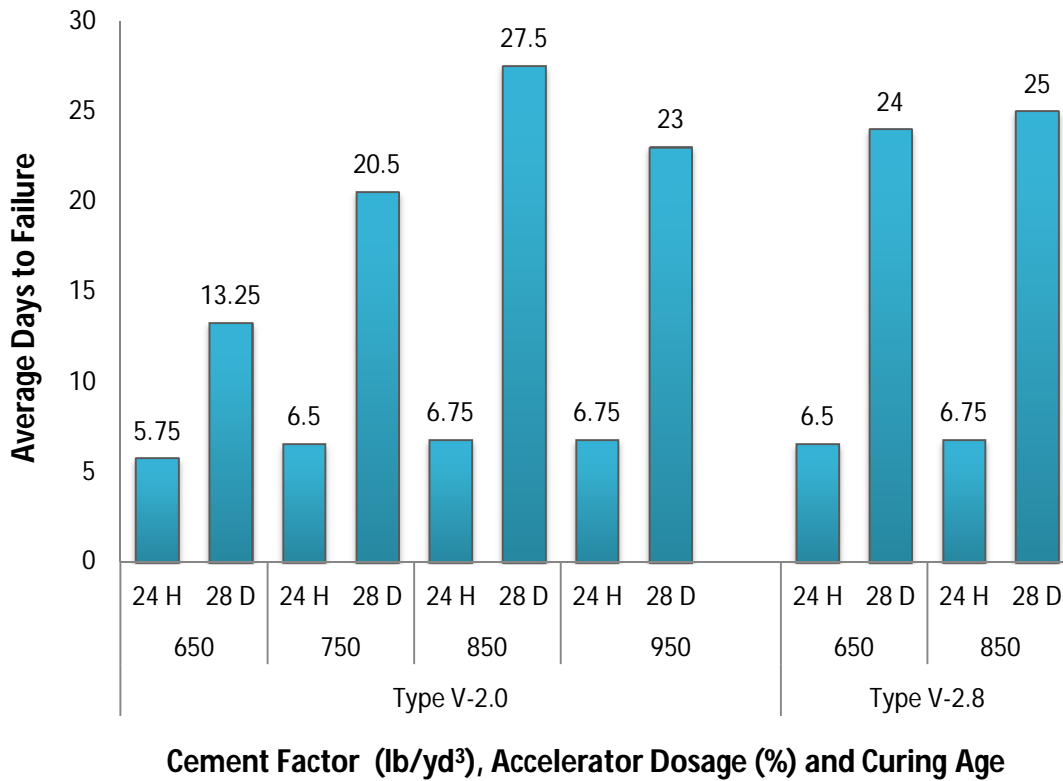

Figure 4-13: Time to Failure for Type V-HES Concretes in Corrosion Test

The corrosion resistance was also improved as curing age was extended. The 28-day failure times of Type V cement concretes were 2.3 to 4.1 times (with an average of 3.4 times) of their 24-hr failure times.

4.2.9. Frost Resistance

The frost resistance of Type V cement concretes was assessed by measuring mass loss of air-entrained concretes subjected to freezing and thawing cycles. Figures 4.14 and 4.15 present mass loss of the studied concretes subjected to freezing and thawing cycles

at different ages of 24 hrs and 28 days, respectively. Figure 4.16 shows the ultimate mass loss of these concretes after 25 freezing and thawing cycles (each cycle consisted of 2 days of freezing and 2 days of thawing). It can be seen that the frost resistance reduced as cement factor and accelerator dosage were increased. It, however, improved (increased) as curing age was extended.

As mentioned earlier, increasing cement content had a negative influence on the frost resistance of Type V cement concretes. For concretes with 2% accelerator, the ultimate mass loss of 24-hr tested mixtures increased by 57.6, 14.5 and 75.8% when the cement content was increased from 650 to 750, 750 to 850 and 850 to 950 lb/yd³, respectively. Similar increases in cement content of 28-day cured concretes resulted in 11.6, 37.7 and 11.7% increases in ultimate mass loss, respectively. A similar trend was seen for concretes with 2.8% accelerator. As their cement content was increased from 650 to 850 lb/yd³, their ultimate mass loss increased by 53.5 and 34.7% for concretes subjected to freeze and thaw cycles at the age of 24 hrs and 28 days, respectively.

It can also be seen that the mass loss increased (frost resistance reduced) when higher dosage of accelerator was used. For concretes tested at 24 hrs, the ultimate mass loss increased by 65.9 and 41.1% for mixtures with cement factors of 650 and 850 lb/yd³ when accelerator dosage was increased from 2 to 2.8%, respectively. These increases were 68.0 and 57.1% for similar concretes cured for 28 days before subjecting to freezing and thawing cycles, respectively.

It was also observed that the frost resistances of 28-day cured concretes were higher than those of 24-hr cured concretes. On average, the ultimate mass loss of 28-day cured concretes was about 26% lower than those only cured for 24 hrs.

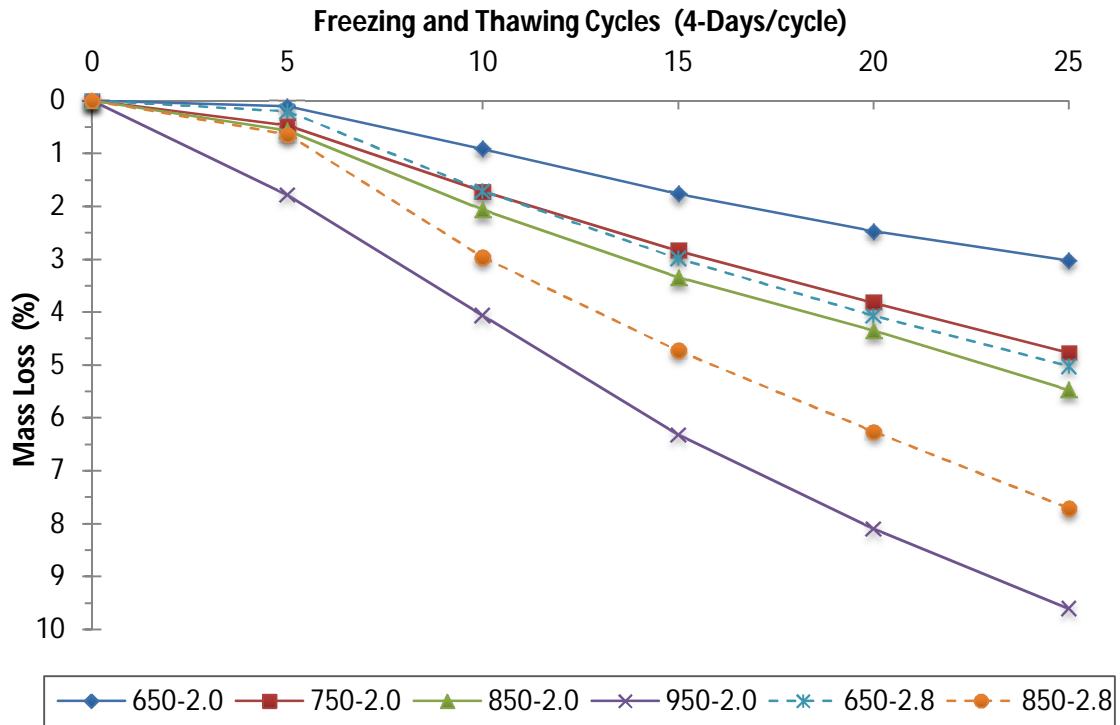

Figure 4-14: Mass Loss of Type V-HES Concretes Tested at the Age of 24 Hrs

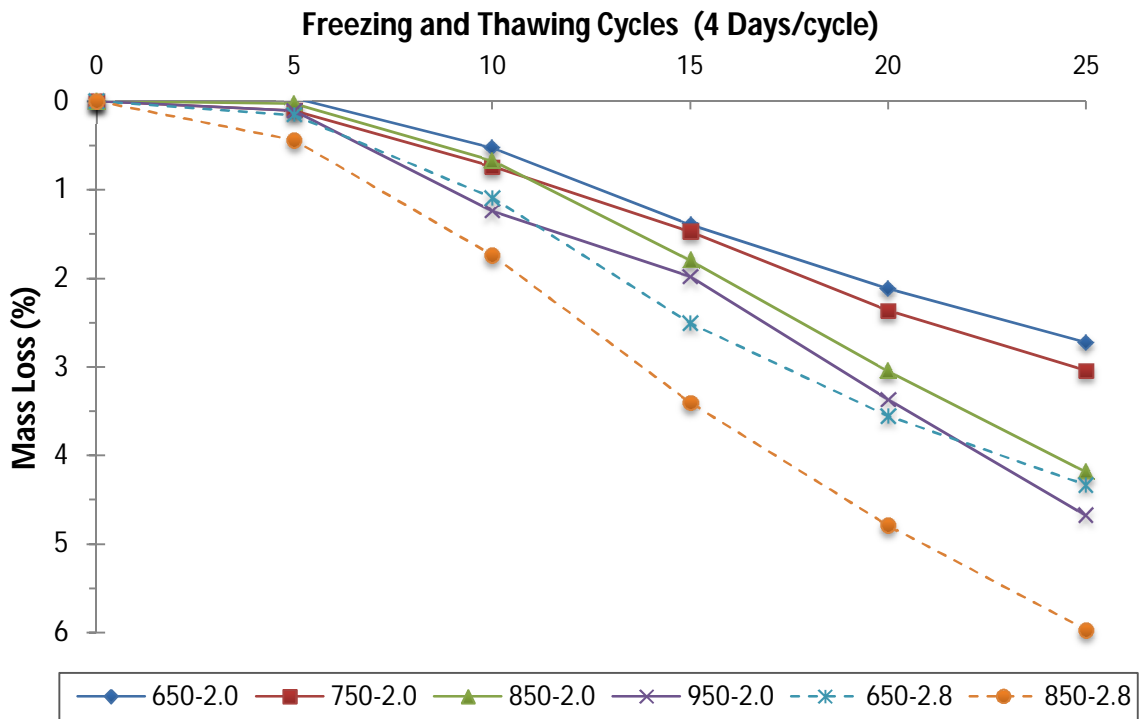

Figure 4-15: Mass Loss of Type V-HES Concretes Tested at the Age of 28 Days

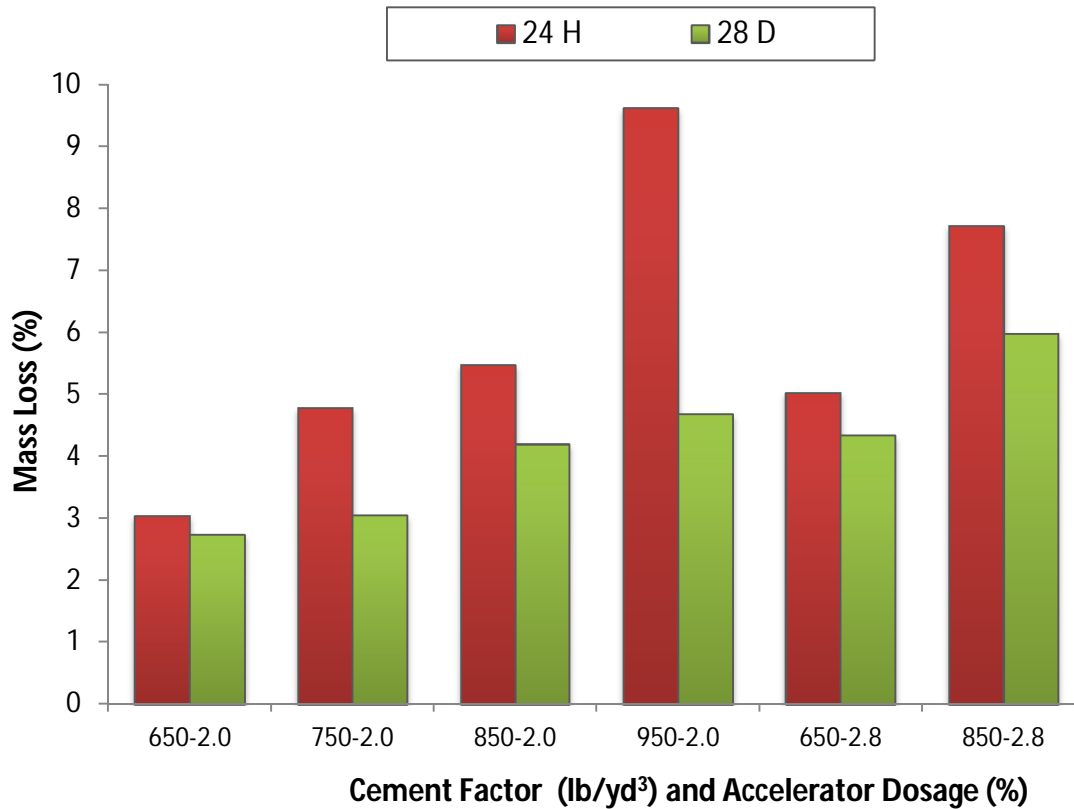

Figure 4-16: Ultimate Mass Loss of Type V-HES Concretes Subjected to 25 Freezing and Thawing Cycles

4.2.10. Abrasion

Table 4.10 documents results of abrasion test for the studied Type V cement concretes. It can be seen that overall, the abrasion depth reduced when cement content, accelerator dosage and curing age were increased.

The abrasion depth of concretes made with 2% accelerator reduced by averagely 3.2, 7.8 and 5.1% when cement content was increased from 650 to 750, 750 to 850 and 850 to 950 lb/yd³, respectively. In the case of concretes containing 2.8% accelerator, the abrasion depths of mixtures with cement content of 850 lb/yd³ were averagely 10.5% lower than those of concretes made with cement content of 650 lb/yd³.

While increases of accelerator dosage didn't show any significant effect on the abrasion depth of 24-hr cured concretes, it reduced the abrasion depth of 28-day cured concretes. For concretes made with Type V cement contents of 650 and 850 lb/yd³, increases in accelerator dosage from 2 to 2.8% resulted in 9.7 and 12.3% reduction in abrasion depth of 28-day cured concretes, respectively.

Abrasion resistance also increased with increases in curing age. As curing age was extended from 24 hrs to 28 day, the abrasion depth reduced by averagely 23.9 and 32.0% for concretes having 2 and 2.8% accelerator, respectively.

Table 4-10: Abrasion Depth of Type V-HES Concretes

Age	Accelerator (%)					
	2.0				2.8	
	Cement Content (lb/yd ³)				Cement Content (lb/yd ³)	
	650	750	850	950	650	850
	Abrasion Depth (mm)					
24 hrs	0.9625	0.9383	0.8569	0.8285	0.9567	0.8794
28 days	0.7400	0.7113	0.6625	0.6166	0.6680	0.5813
	Abrasion Depth (in)					
24 hrs	0.03789	0.03694	0.03374	0.03262	0.03766	0.03462
28 days	0.02913	0.02800	0.02608	0.02427	0.02630	0.02288

Chapter 5 Hardened Properties of High Early-Age Strength Type III Portland Cement Concretes

5.1. Introduction

The second phase of this study dealt with evaluation of different properties of high early-age strength Type III Portland cement concretes. The three different variables considered for this phase of study were as follows:

- *Cement factor (cement content):*

Influences of three different cement contents of 550, 650 and 750 lb/yd³ on properties of high early-age strength Type III cement concretes were studied.

- *Use of air-entraining admixture:*

In order to assess effects of air-entrainment on hardened properties of high early-age strength Type III cement concretes, the designed concretes were made with and without air-entraining admixture.

- *Curing age:*

Effects of curing age on the properties of high early-age strength Type III cement concretes were studied by testing hardened concretes at their opening time, 24 hrs, and 28 days.

5.2. Results and Discussion

Similar to the first phase, a comprehensive experimental program was devised to assess hardened properties of high early-age strength Type III cement concretes including mechanical properties (compressive and flexural strengths), transport properties (absorption, water permeability, rapid chloride penetration, and rapid chloride migration), durability properties (frost resistance, chloride induced corrosion, and resistance to wear), and dimension stability (drying shrinkage). As mentioned earlier, three testing times having different curing conditions as described in Chapter 2, depending on the property tested, were considered at opening time, 24 hrs, and 28 days.

5.2.1. Compressive Strength

Table 5.1 presents results of compressive strength test for the studied high early-age strength Type III cement concretes at different curing ages including opening time, 24 hrs and 28 days. Table 5.2 reports the opening times and range of compressive strengths at opening times. Effects of dominant variables on the compressive strength and opening time of the studied Type III cement concretes are discussed below.

5.2.1.1. Effects of Cement Content

Figure 5.1 presents the results for the opening time compressive strength of Type III cement concretes having different cement factors. It can be seen that as cement content was increased, the studied concretes developed their compressive strength quicker, thus opening times shortened.

The opening time of the studied concretes reduced by averagely half an hour for each 100 lbs increases in the cement factor. In the case of non air-entrained concretes, the opening times reduced from 5.5 hrs for mixtures having cement content of 550 lb/yd³ to 5, and 4.5 hrs for mixtures with cement content of 650 and 750 lb/yd³, respectively. Similarly, for air-entrained concretes, the opening times reduced from 6.5 hrs for mixtures with cement content of 550 lb/yd³ to 6 and 5.5 hrs for mixtures with cement content of 650 and 750 lb/yd³, respectively.

Effect of cement factor on the 24-hr and 28-day compressive strengths of Type III cement concretes is presented in Figure 5.2. It can be seen that overall, the compressive strength of Type III cement concretes with different cement factors were almost similar. On average, the 24-hr compressive strength reduced by 1.7% when the cement factor was increased from 550 to 650 lb/yd³ and increased by 1% as the cement factor was increased from 650 to 750 lb/yd³. The 28-day compressive strength reduced by averagely 6.2% when the cement content was increased from 550 to 650 lb/yd³ and increased by 0.6% as the cement content was increased from 650 to 750 lb/yd³.

Table 5-1: Compressive Strength of Type III-HES Concretes (psi)

Mixture Identification	Testing Time			
	Opening Time	24 hrs	28 days	
Type III	550	3649	8661	12237
	AE-550	3566	5896	8318
	650	3421	8496	11826
	AE-650	3770	5806	7571
	750	3215	8117	11338
	AE-750	3284	6176	7969

* AE: Air-entrained

Table 5-2: Opening Time of Type III-HES Concretes and Range of Compressive Strengths at Opening Times

Mixture Identification		Compressive Strength (psi)			Opening Time (hrs)	
		Minimum	Average	Maximum	Non Air-Entrained	Air-Entrained
Type III	550	3147	3649	4250	5.5	
	AE-550	3006	3566	4178		6.5
	650	3195	3421	3792	5	
	AE-650	3062	3770	4313		6
	750	3027	3215	3416	4.5	
	AE-750	3012	3284	3556		5.5

* AE: Air-entrained

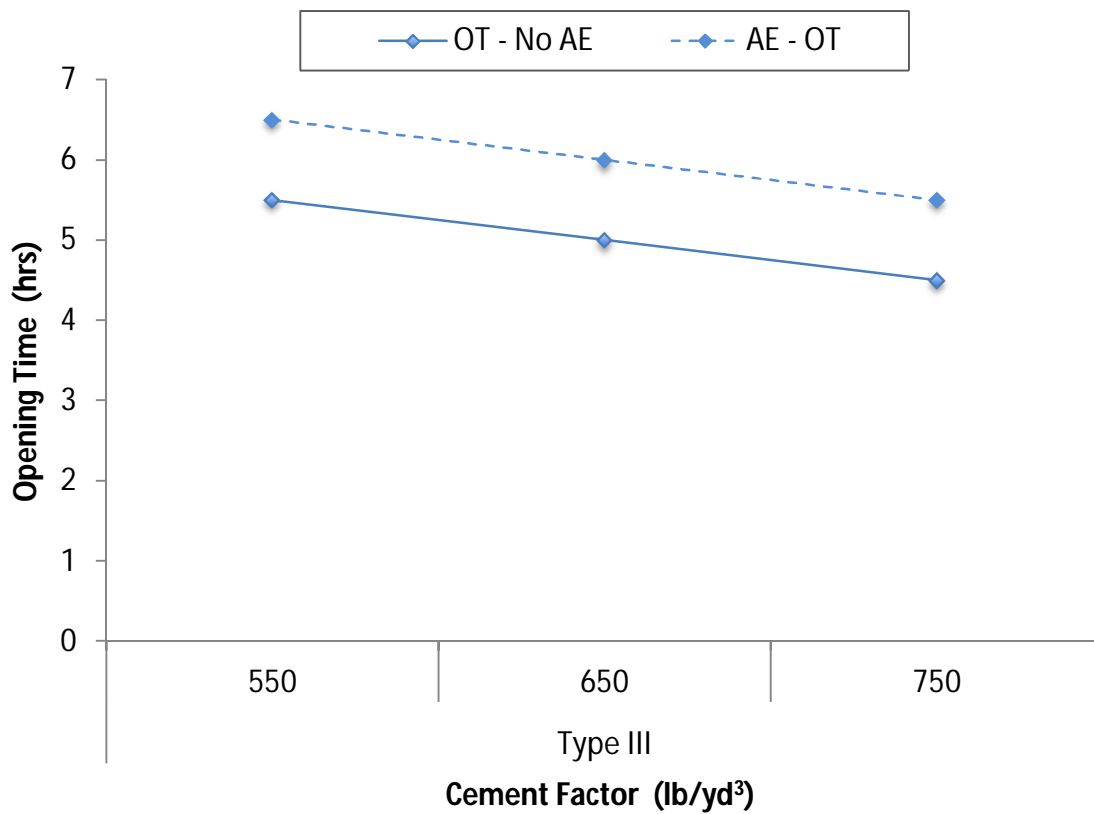

Figure 5-1: Opening Time of Type III-HES Concrete

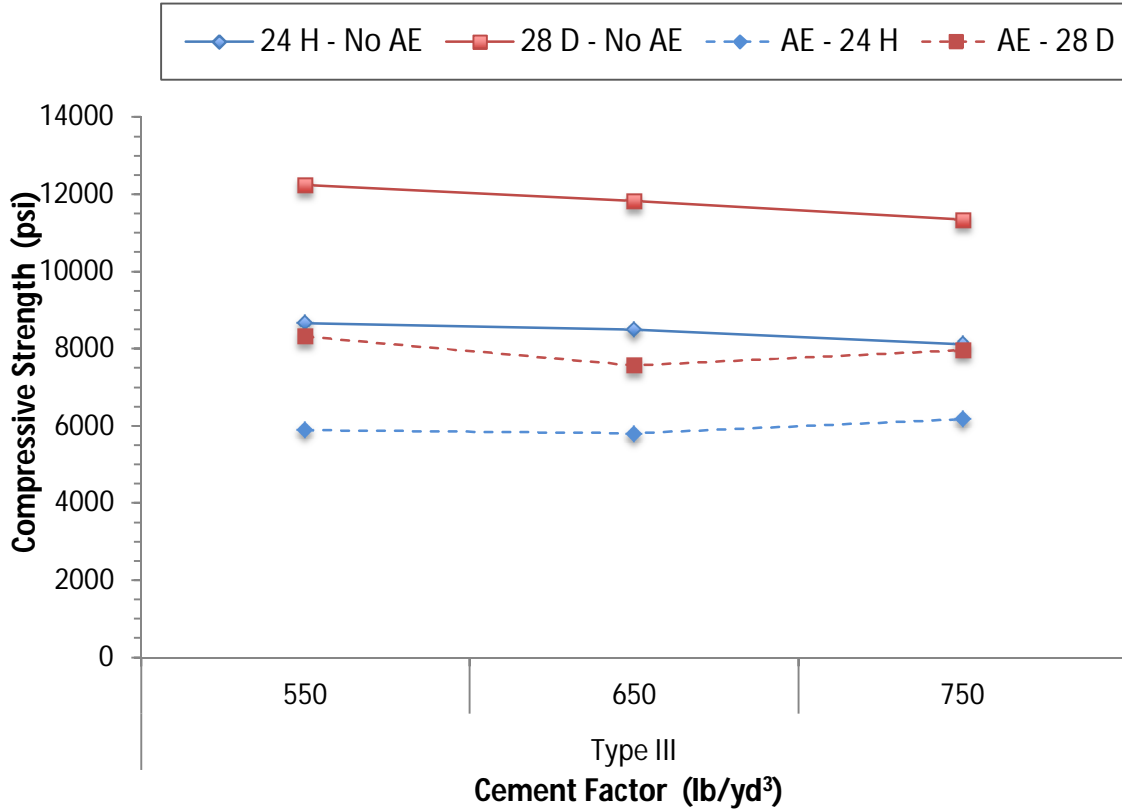

Figure 5-2: Compressive Strength of Type III-HES Concretes at 24 Hrs and 28 Days

5.2.1.2. Effects of Air-Entraining Admixture

Figure 5.1 shows effects of air-entraining admixture on the opening time of Type III cement concretes. It can be seen that the opening times increased when air-entraining admixture was added to the mixtures.

The opening times of air-entrained concretes were averagely 1 hr more than those of non air-entrained concretes. When air-entraining admixture was added to the mixtures, the opening times increased from 5.5 to 6.5, 5 to 6, and 4.5 to 5.5 hrs for cement factors of 550, 650 and 750 lb/yd³, respectively.

Figure 5.2 presents the effect of entrained air on compressive strength of the studied Type III cement concretes. It can be seen that the compressive strength significantly reduced when air-entraining admixture was added to the mixtures. Inclusion of air-entraining admixture reduced the 24-hr compressive strengths by 31.9, 31.7 and 23.9% for mixtures with cement factors of 550, 650 and 750 lb/yd³, respectively. Similarly, addition of air-entraining admixture resulted in averagely 32.0, 36.0 and 29.7% reduction in the 28-day compressive strength of concretes made with cement factors of 550, 650 and 750 lb/yd³, respectively.

5.2.1.3. Effects of Curing Age

Effect of curing age on the compressive strength of Type III cement concretes can be seen in Table 5.1 and Figure 5.2. Overall, the strength development was quick due to use of accelerator and high blain of Type III cement. On average, the opening time and 24-hr compressive strengths of the studied Type III cement concretes were about 37 and 73% of their 28-day compressive strengths, respectively.

5.2.2. Flexural Strength

Table 5.3 presents results of flexural strength for the studied high early-age strength Type III cement concretes at different curing ages, including opening times, 24 hrs and 28 days. These results are also shown in Figure 5.3. It can be seen that the flexural strength of the studied concretes were in the range of 460 to 620 psi at their opening times. All the tested samples had flexural strengths of higher than 440 psi at their opening times.

The flexural strength reduced with increases in cement content. The 24-hr flexural strengths reduced by 8.2 and 8.3% when the cement factor was increased from 550 to 650 and 650 to 750 lb/yd³, respectively. For similar concretes, the same increases in cement content resulted in 4.9 and 6.6% reduction in the 28-day flexural strengths, respectively.

The studied concretes developed majority of their flexural strength within the first day due to use of accelerator and high blain of Type III cement. On average, the opening time and 24-hr flexural strengths of the studied Type III cement concretes were about 40 and 70% of their 28-day flexural strengths, respectively.

Table 5-3: Flexural Strength of Type III-HES Concretes

Mixture Identification	Testing Age	Flexural Strength (psi)			
		Average	Maximum	Minimum	
Type III	550	Opening time	622	660	583
		24 hr	1043	1136	979
		28 day	1444	1506	1382
	650	Opening time	545	575	507
		24 hr	957	1011	905
		28 day	1373	1451	1207
	750	Opening time	466	485	441
		24 hr	878	933	848
		28 day	1282	1346	1187

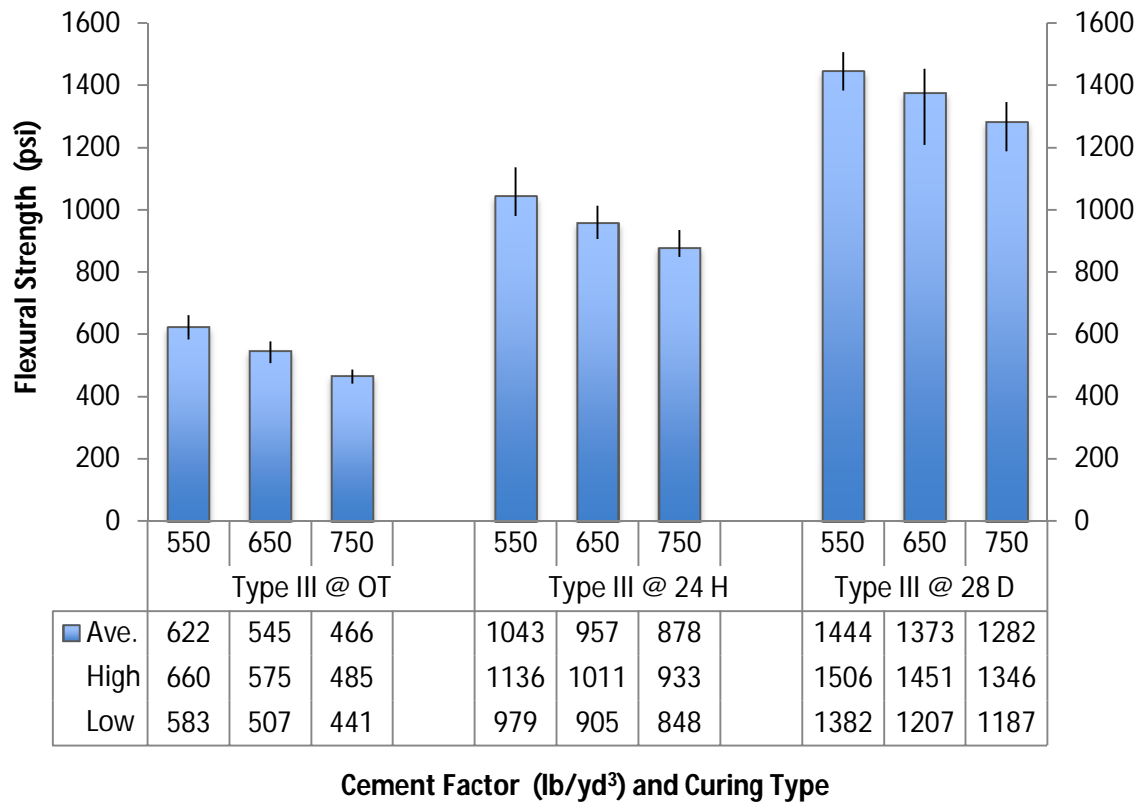

Figure 5-3: Flexural Strength of Type III-HES Concretes

5.2.3. Absorption and Volume of Permeable Voids

Tables 5.4 presents results of absorption test for the studied high early-age strength Type III cement concretes at different curing ages of opening times, 24 hrs and 28 days. The effects of dominant variables on the absorption and volume of permeable voids of the studied concretes are discussed below.

Table 5-4: Results of Absorption Test for Type III-HES Concretes

Mixture Identification	Testing Age	Absorption After Immersion (%)	Absorption After Immersion & Boiling (%)	Volume of Permeable Voids (%)	
Type III	550	Opening time	3.42	3.52	8.70
		24 hrs	2.93	3.13	7.75
		28 days	1.36	1.51	3.72
	AE - 550	Opening time	3.79	4.17	9.45
		24 hrs	3.49	3.91	8.82
		28 days	1.70	1.93	4.50
	650	Opening time	3.83	4.10	9.95
		24 hrs	3.69	3.82	9.37
		28 days	1.50	1.68	4.16
	AE - 650	Opening time	4.21	4.50	10.28
		24 hrs	3.78	4.23	9.62
		28 days	1.99	2.22	5.08
	750	Opening time	5.01	5.21	12.35
		24 hrs	4.56	4.69	11.20
		28 days	2.01	2.14	5.19
	AE - 750	Opening time	4.93	5.28	11.82
		24 hrs	4.65	5.00	11.26
		28 days	2.76	3.05	6.89

* AE: Air-entrained

5.2.3.1. Effects of Cement Content

Figure 5.4 shows absorption and volume of permeable voids of high early-age strength Type III cement concretes tested at different ages of curing including opening times, 24 hrs and 28 days. It can be seen that the absorption and void contents of the studied concretes increased as cement content was increased.

For non air-entrained concretes, increases in the cement factor from 550 to 650 and 650 to 750 lb/yd³ increased the absorption of concretes tested at opening times by averagely 12.0 and 30.8%, respectively. Similar increases in the cement factor increased

24-hr absorption by 25.9 and 23.6%, and 28-day absorption by 10.3 and 34.0%, respectively. Similar increases in the cement content increased the opening time-void contents by 14.4 and 24.1%, 24-hr void contents by 20.9 and 19.5%, and 28-day void contents by 11.8 and 24.8%, respectively.

In the case of air-entrained concretes, increases in the cement content from 550 to 650 and 650 to 750 lb/yd³ increased opening time absorption by 11.1 and 17.1%, 24-hr absorption by 8.3 and 23.0%, and 28-day absorption by 17.1 and 38.7%, respectively. The same increases in the cement content increased the void contents by 8.8 and 15% at opening time, 9.1 and 17% for 24-hr tested samples, and 12.9 and 35.6% for 28-day cured samples, respectively.

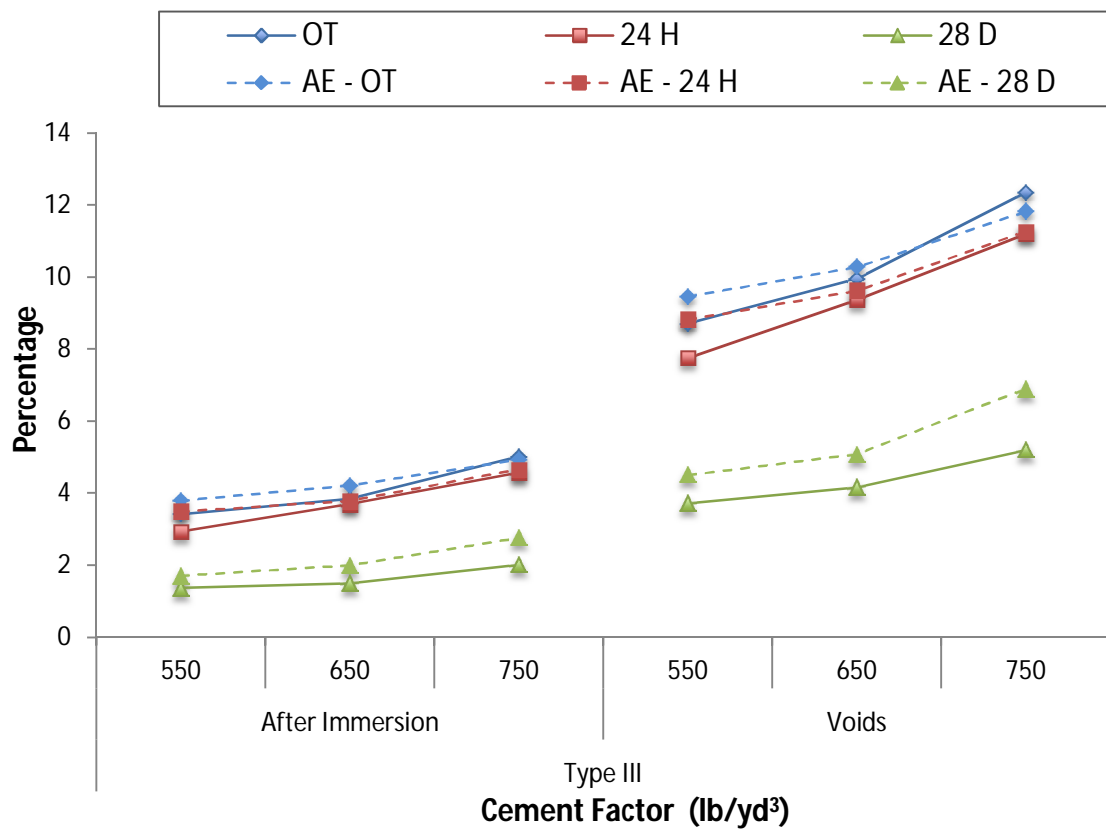

Figure 5-4: Absorption and Volume of Permeable Voids of Type III-HES Concretes

5.2.3.2. Effects of Air-Entraining Admixture

Figure 5.4 also shows effects of air-entraining admixture on the absorption and volume of permeable voids of Type III cement concretes. It can be seen that the absorption and void contents increased when air-entraining admixture was added to the mixtures.

Inclusion of air-entraining admixture resulted in averagely 6.4, 7.8 and 31.7% increases in the absorption of concretes tested at opening time, 24 hrs and 28 days, respectively. For similar testing days and the same concretes, the void contents increased by averagely 2.5, 5.7 and 25.3%, respectively, when air-entraining admixture was added.

5.2.3.3. Effects of Curing Age

Effects of curing age on the absorption and void contents of the studied concretes are also shown in Figure 5.4. It can be seen that the absorption and void contents reduced as the curing age was increased. On average, the absorption reduced by 8.5 and 51.4% when curing age was extended from opening time to 24 hrs and 24 hrs to 28 days, respectively. For similar extensions of curing age, the void contents reduced by averagely 7.3 and 49.4%, respectively.

5.2.4. Rapid Chloride Penetration Test

Table 5.5 and Figure 5.5 document results of rapid chloride penetration test (RCPT) for the studied high early-age strength Type III cement concretes tested at two curing ages of 24 hrs and 28 days. The effects of dominant variables on the RCPT passing charges are discussed below.

Table 5-5: Passing Charge of Type III-HES Concretes

Mixture Identification	Testing Time	Passing Charges (Coulombs)			
		Average	Maximum	Minimum	
Type III	550	24 hrs	2556	2950	2242
		28 days	1604	1938	1292
	AE - 550	24 hrs	2427	3015	2038
		28 days	1298	1486	1107
	650	24 hrs	3178	3805	2558
		28 days	2016	2336	1661
	AE - 650	24 hrs	2791	3360	2268
		28 days	1565	1880	1217
	750	24 hrs	3592	4320	2841
		28 days	2210	2545	1721
	AE - 750	24 hrs	3432	3642	3048
		28 days	1940	2120	1718

* AE: Air-entrained

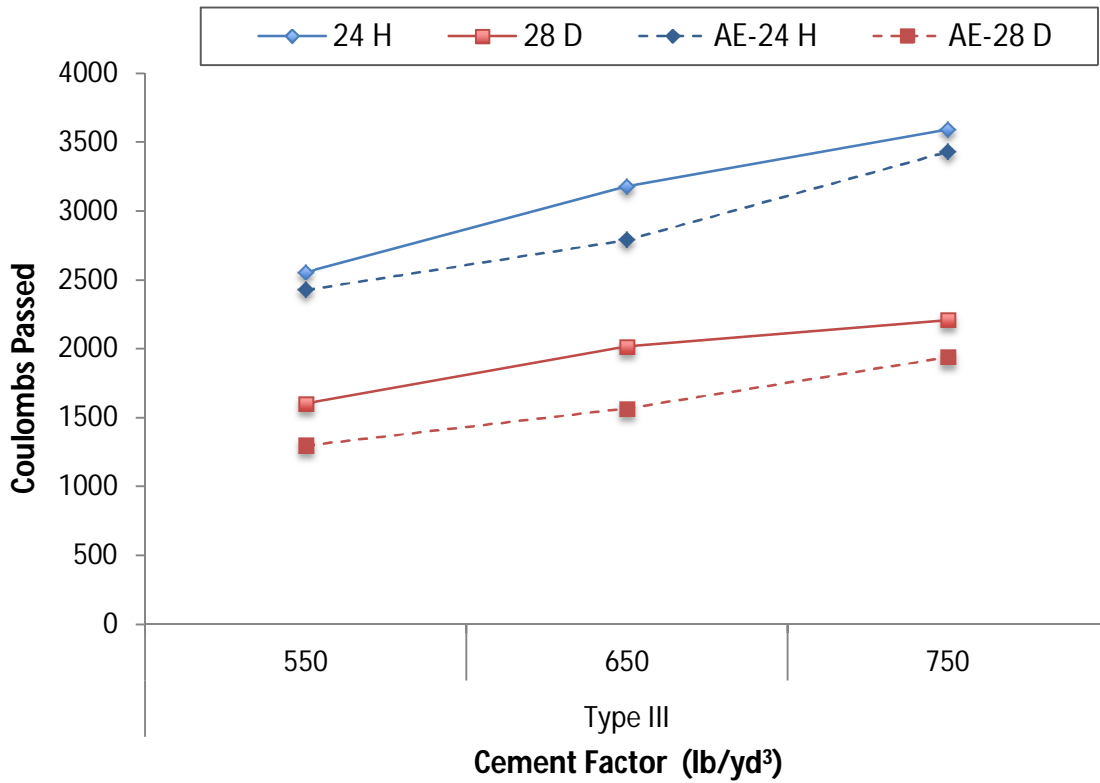

Figure 5-5: Passing Charge of Type III-HES Concretes

5.2.4.1. Effects of Cement Content

Figure 5.5 shows effects of cement factor on the passing charges of Type III cement concretes. It can be seen that the passing charges increased as cement content was increased.

In the case of non air-entrained concretes, the 24-hr passing charges increased by averagely 24.3 and 13.0% when the cement factor was increased from 550 to 650 and 650 to 750 lb/yd³, respectively. Similar increases in the cement factor increased the 28-day RCPT values of these concretes by 25.7 and 9.6%, respectively.

In the case of air-entrained concretes, increases in the cement content from 550 to 650 and 650 to 750 lb/yd³ resulted in averagely 15.0 and 23.0% increases in the 24-hr passing charges, and 20.6 and 24% increases in the 28-day passing charges, respectively.

5.2.4.2. Effects of Air-Entraining Admixture

Figure 5.5 also presents effects of air-entraining admixture on passing charges of Type III cement concretes. It can be seen that the passing charges reduced when air-entraining admixture was added to the concrete mixtures.

Inclusion of air-entraining admixture resulted in averagely 5.0, 12.2 and 4.5% reduction in the 24-hr passing charges of concretes having cement contents of 550, 650 and 750 lb/yd³, respectively. For similar cement factors, addition of air-entraining admixture reduced the 28-day passing charges by 19.1, 22.4 and 12.2%, respectively.

5.2.4.3. Effects of Curing Age

Figure 5.5 also shows effect of curing age on RCPT results. It can be seen that the passing charges reduced by nearly 40% as curing age was increased from 24 hrs to 28 days. The 28-day passing charges of the studied concretes were 36 to 46% (with an average of 41%) lower than the 24-hr passing charges.

5.2.5. Rapid Chloride Migration Test

Table 5.6 and Figure 5.6 present results of rapid chloride migration test (RMT) for the studied Type III cement concretes measured at two testing times of 24 hrs and 28 days. The effects of dominant variables on the chloride penetration depth of the studied concretes are discussed below.

Table 5-6: Chloride Penetration Depth of Type III-HES Concretes

Mixture Identification	Testing Time	Chloride Penetration Depth (in)			
		Average	Maximum	Minimum	
Type III	550	24 hrs	1.33	1.36	1.32
		28 days	0.73	0.78	0.69
	AE - 550	24 hrs	1.32	1.34	1.29
		28 days	0.72	0.75	0.67
	650	24 hrs	1.19	1.25	1.11
		28 days	0.70	0.74	0.66
	AE - 650	24 hrs	1.21	1.23	1.19
		28 days	0.69	0.72	0.65
	750	24 hrs	1.16	1.20	1.09
		28 days	0.70	0.77	0.66
	AE - 750	24 hrs	1.19	1.24	1.16
		28 days	0.67	0.72	0.64

* AE: Air-entrained

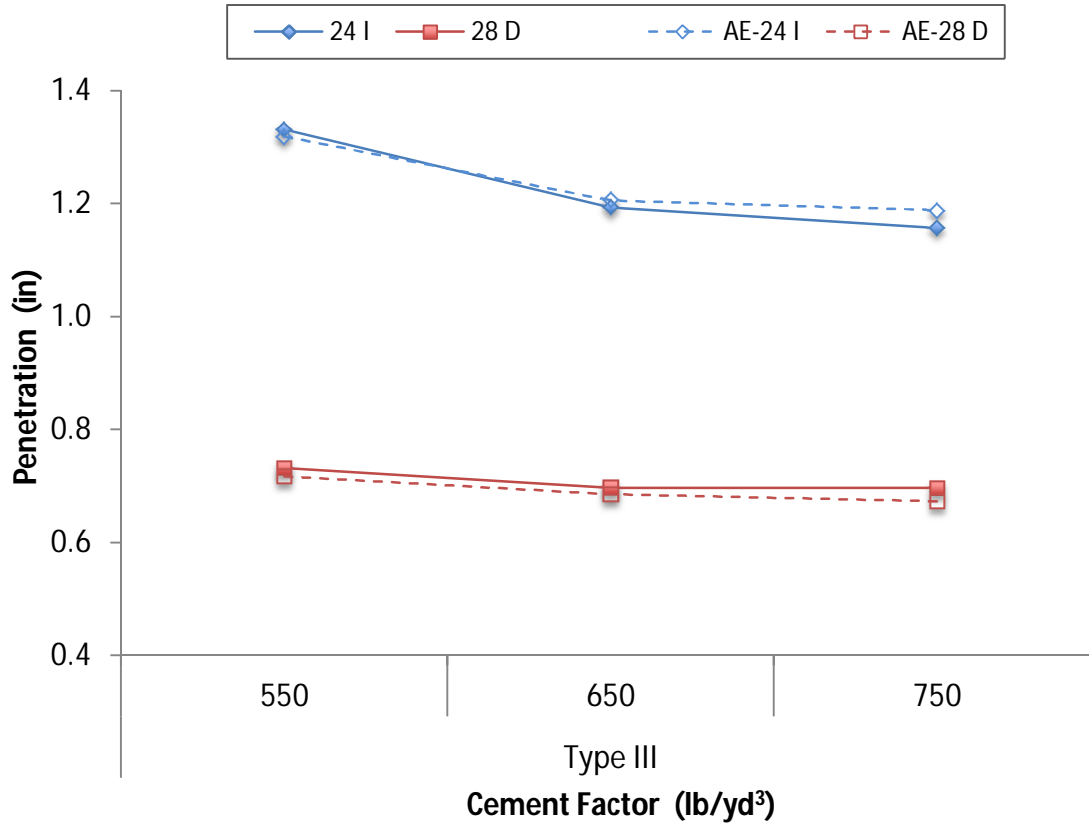

Figure 5-6: Chloride Penetration Depth of Type III-HES Concretes

5.2.5.1. Effects of Cement Content

Figure 5.6 shows effects of cement factor on the chloride penetration depth of Type III cement concretes. It can be seen that overall, the chloride penetration depth slightly reduced as cement content was increased.

In the case of non air-entrained concretes, the 24-hr chloride penetration depth reduced by averagely 10.5 and 2.5% when the cement factor was increased from 550 to 650 and 650 to 750 lb/yd³, respectively. Similar increases in the cement factor marginally decreased the 28-day chloride penetration depths of these concretes by 4.1 and 0%, respectively.

In the case of air-entrained concretes, increases in the cement content from 550 to 650 and 650 to 750 lb/yd³ reduced chloride penetration depth by 8.3 and 1.7% for 24-hr cured concretes, and 4.9 and 2.9% for 28-day cured concretes, respectively.

5.2.5.2. Effects of Air-Entraining Admixture

Figure 5.6 also shows effects of air-entraining admixture on the chloride penetration depth of Type III cement concretes. It can be seen that overall, the chloride penetration depths of Type III concretes were similar with and without air-entraining admixture.

As air-entraining admixture was added to the Type III cement concretes, the 24-hr chloride penetration depth increased by averagely 1.2%. On the other hand, inclusion of air-entraining admixture resulted in averagely 2.4% reduction in chloride penetration depth of 28-day cured concretes.

5.2.5.3. Effects of Curing Age

Effects of curing age on the chloride penetration depth of the studied Type III cement concretes are shown in Figure 5.6. It can be seen that the penetration depths significantly reduced as curing age was extended from 24 hrs to 28 days. The 28-day chloride penetration depths of the studied concretes were 40 to 46% (with an average of 43%) lower than the 24-hr chloride penetration depths.

5.2.6. Water Permeability

Table 5.7 and Figure 5.7 show results of water penetration depth for the studied Type III cement concretes tested at the ages of 24 hrs and 28 days. It can be seen that the depth of penetration increased as cement content was increased.

The depths of water penetration slightly increased with increases in the cement factor. The 24-hr water penetration depths increased by 16.1 and 24.3% when the cement content was increased from 550 to 650 and 650 to 750 lb/yd³, respectively. Similar increases in the cement factor increased the 28-day water penetration depths of these concretes by 12.3 and 8.0%, respectively.

The depth of water penetration reduced as curing age was increased. The reductions, however, were insignificant compared to the reductions observed for the other transport properties. On average, the 28-day water penetration depths of Type III cement concretes were about 19% lower than their 24-hr water penetration depths.

Table 5-7: Water Penetration Depth of Type III-HES Concretes

Age	Cement Factor (lb/yd ³)		
	550	650	750
	Water Penetration Depth (mm)		
24 hrs	10.264	11.919	14.817
28 days	8.877	9.970	10.770
	Water Penetration Depth (in)		
24 hrs	0.4041	0.4693	0.5833
28 days	0.3495	0.3925	0.4240

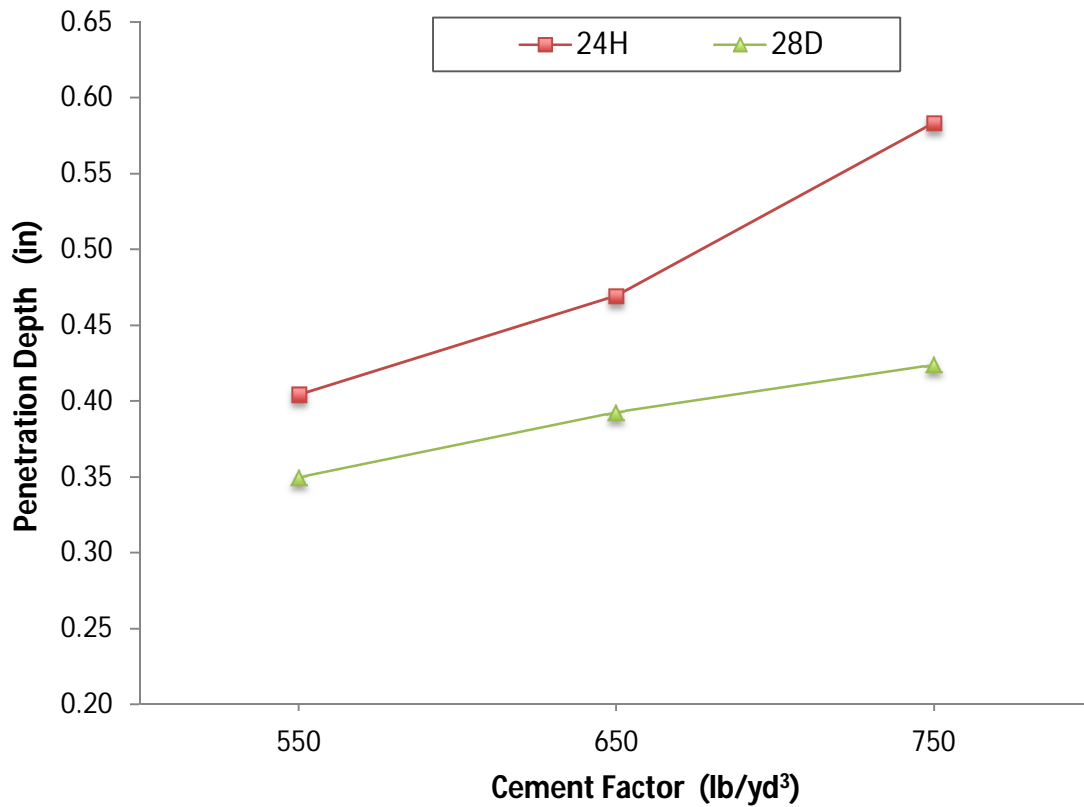

Figure 5-7: Water Penetration Depth of Type III-HES Concretes

5.2.7. Drying Shrinkage

Figures 5.8 through 5.10 show drying shrinkage of Type III cement concretes for samples transferred to the shrinkage room at the ages of their opening time, 24 hrs and 28 days, respectively. Effects of cement content and curing age were studied on the drying shrinkage of Type III cement concretes, which discussed in the following subsections.

5.2.7.1. Effects of Cement Content

Figures 5.8 through 5.10 present effects of cement factor on the drying shrinkage of Type III cement concretes. It can be seen that the drying shrinkage increased with increases in cement content.

Figure 5.11 presents the ultimate drying shrinkage of Type III cement concretes kept in shrinkage room for 7.5 months. The drying shrinkage increased by averagely 22.1 and 17.0% when the cement factor was increased from 550 to 650 and 650 to 750 lb/yd³, respectively. These increases were 24.1 and 18.3% for concretes transferred to shrinkage room at their opening time; 28.0 and 15.0% for 24-hr cured concretes; and 14.1 and 17.8% for 28-day cured concretes, respectively.

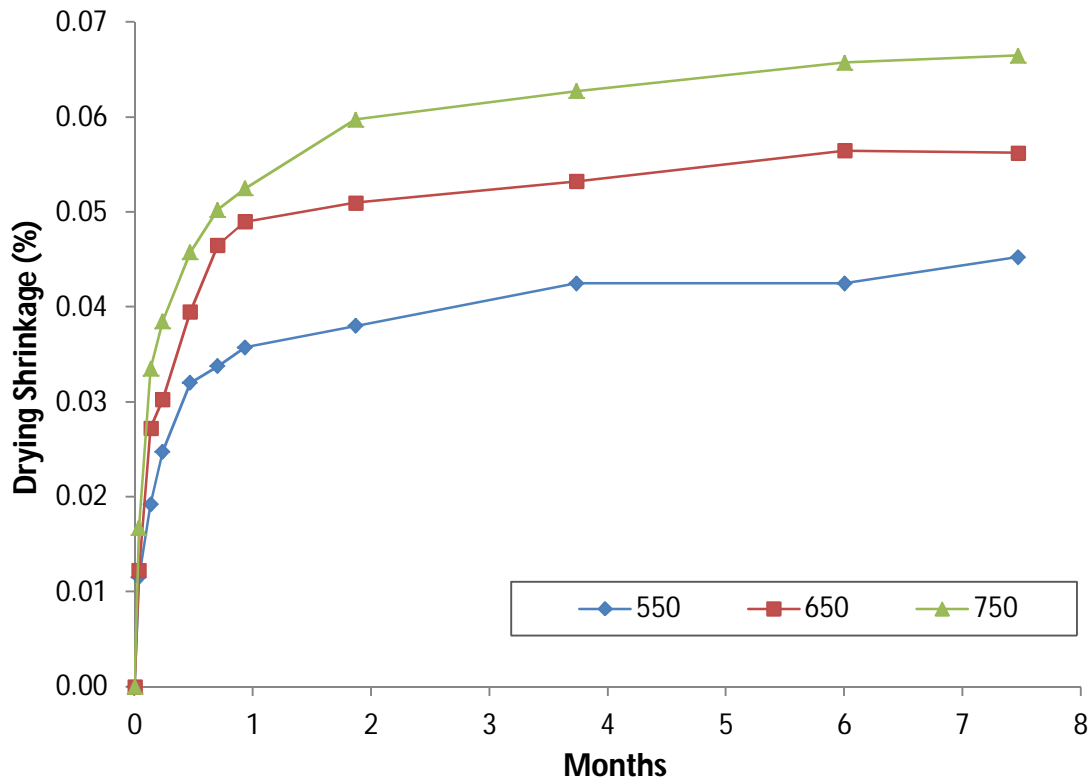

Figure 5-8: Drying Shrinkage of Type III-HES Concretes Transferred to Shrinkage Room at Opening Time

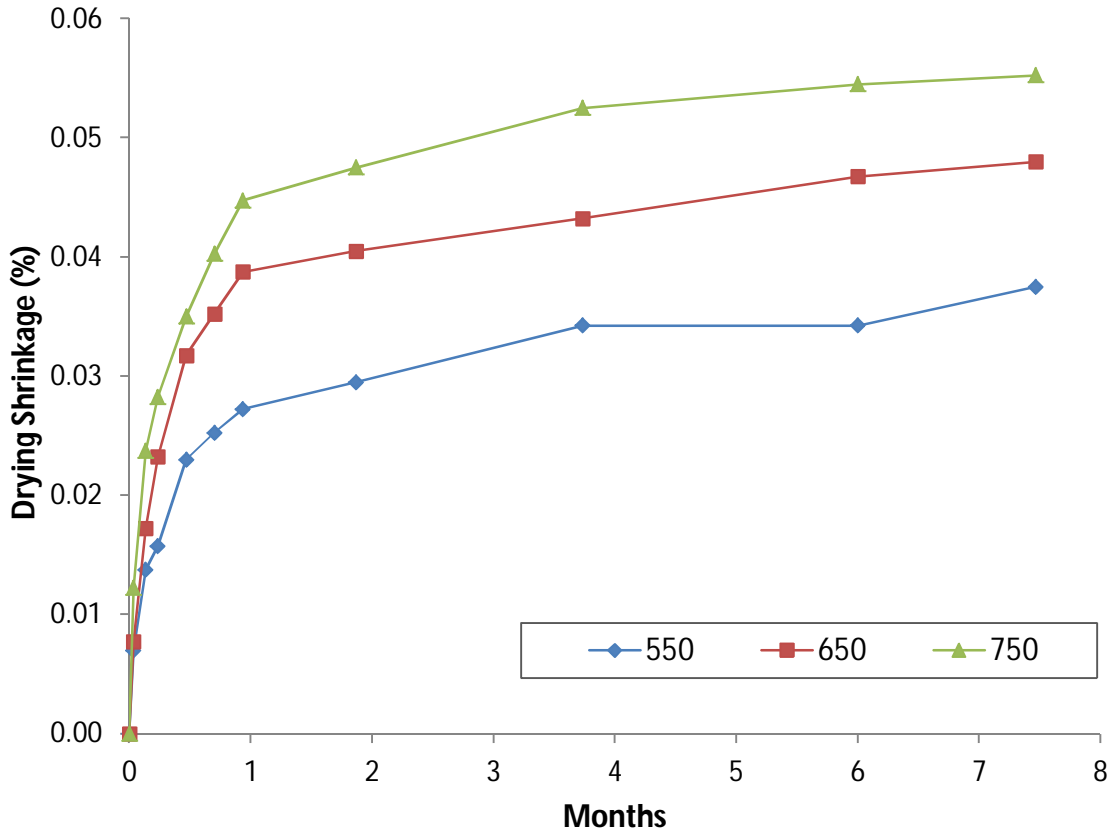

Figure 5-9: Drying Shrinkage of Type III-HES Concretes Transferred to Shrinkage Room at the Age of 24 Hrs

5.2.7.2. Effects of Curing Age

Figure 5.11 shows effect of curing age on the ultimate (7.5 months) drying shrinkage of Type III cement concretes. It can be seen that the drying shrinkage reduced as curing age was increased. The drying shrinkage of the studied concretes reduced by averagely 16.3 and 15.2% when curing age was increased from opening time to 24 hrs and 24 hrs to 28 days, respectively.

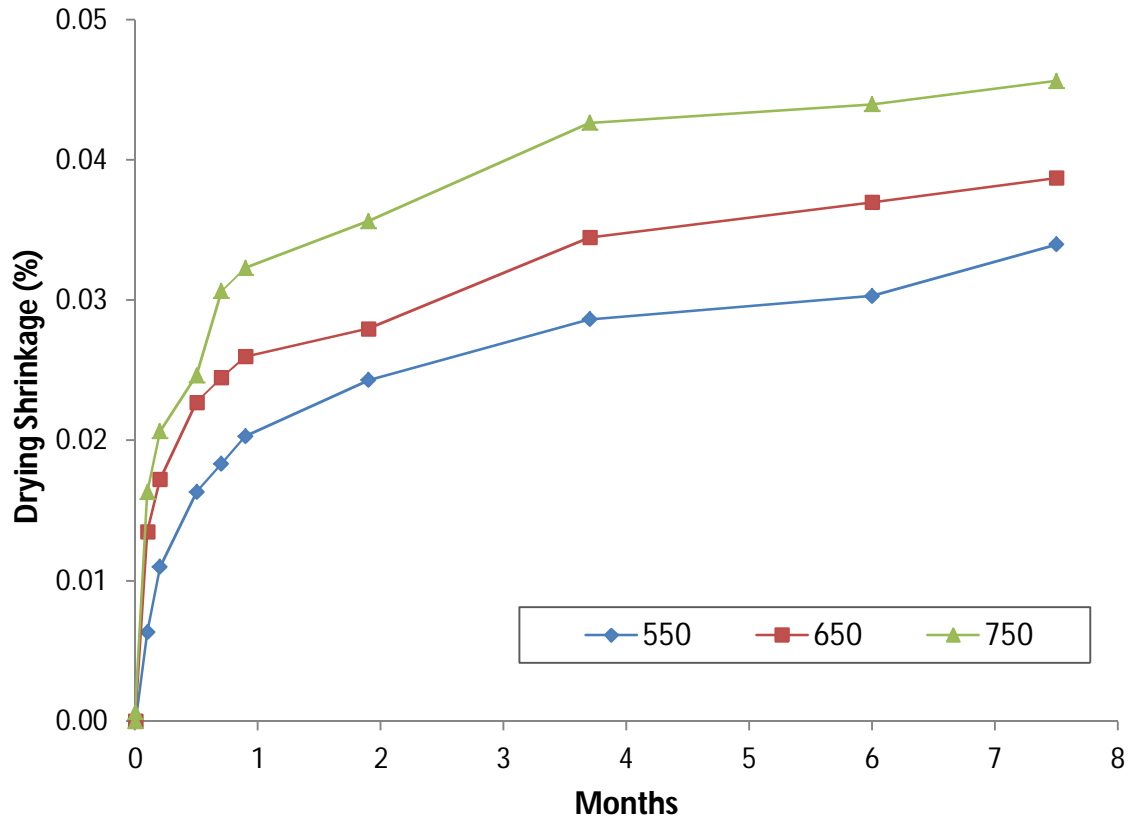

Figure 5-10: Drying Shrinkage of Type III-HES Concretes Transferred to Shrinkage Room at the Age of 28 Days

5.2.7.3. Comparison with NDOT Specification

NDOT specification suggests a limitation on the drying shrinkage of concretes kept in shrinkage room for 28 days. This limit is 0.06% shrinkage. Figure 5.11 also shows the drying shrinkage of concretes after 28 days in shrinkage room. It can be seen all the studied concretes had lower shrinkage than the specification limit.

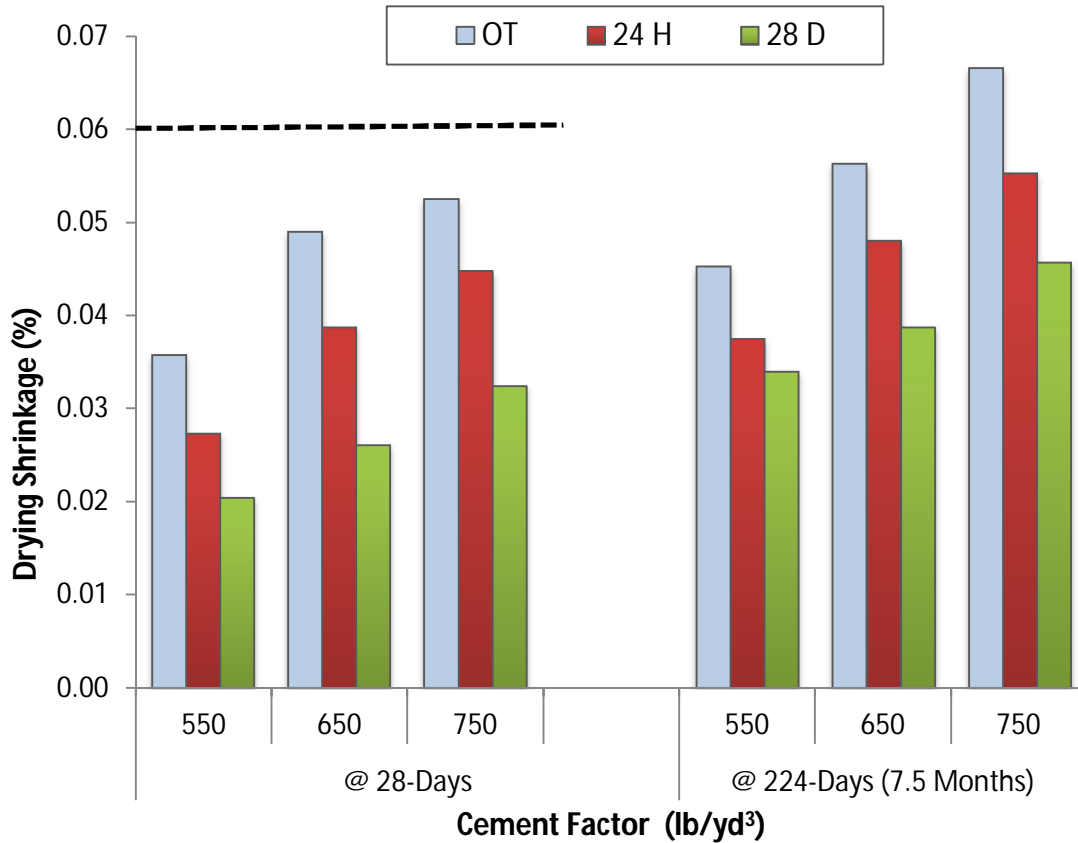

Figure 5-11: The Drying Shrinkage of Type III-HES Concretes After 28 Days and 7.5 Months in Shrinkage Room

5.2.8. Corrosion Resistance

Table 5.8 and Figure 5.12 present failure time of the studied Type III cement concretes in corrosion test. It can be seen that overall the corrosion resistance improved (failure time increased) as cement content was increased.

The 24-hr corrosion resistance improved by nearly 23% with each 100 lbs increases in cement content. The 24-hr failure time increased from 4 to 5 days (25%) and 5 to 6 days (20%) when the cement content was increased from 550 to 650 and 650 to 750 lb/yd³, respectively. Similar increases in the cement factor increased the 28-day

failure time of these concretes by 25 and 30%, respectively. The failure time of 28-day cured concretes were 8, 10 and 13 days for the cement contents of 550, 650 and 750 lb/yd³, respectively.

The corrosion resistance significantly improved as curing age was extended. The 28-day failure times of Type III cement concretes were nearly 2 times of their 24-hr failure times.

Table 5-8: Time to Failure of Type III-HES Concretes in Corrosion Test

Mixture Identification	Curing Age	Failure Time (days)	
Type III	550	24 hrs	4
		28 days	8
	650	24 hrs	5
		28 days	10
	750	24 hrs	6
		28 days	13

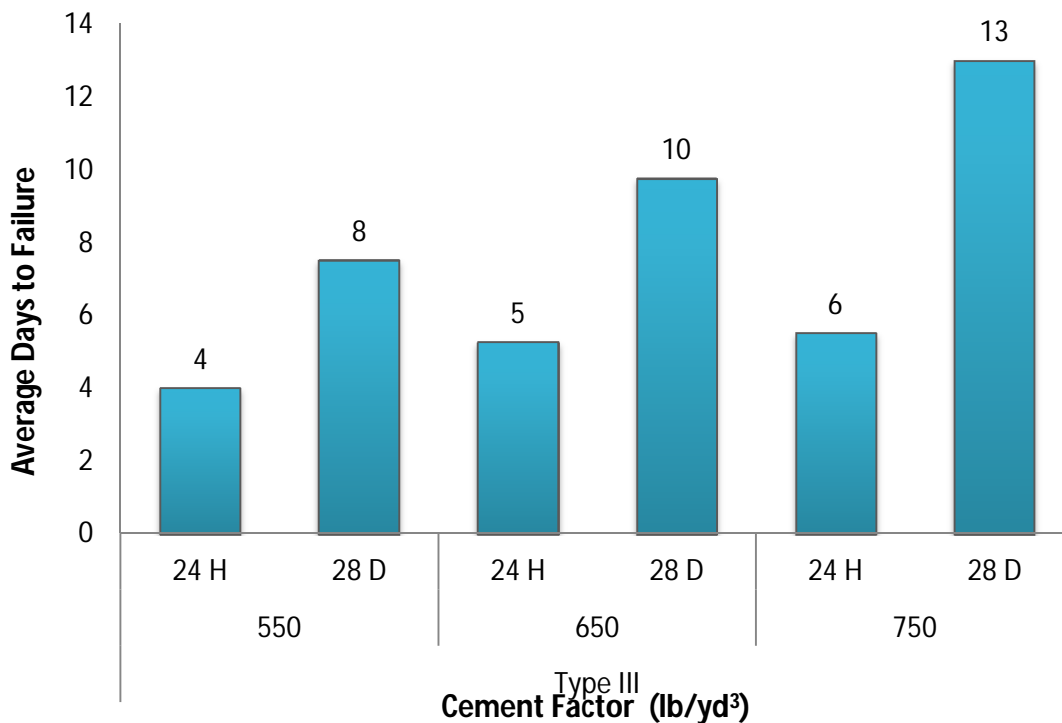

Figure 5-12: Failure Time of Type III-HES Concretes in Corrosion Test

5.2.9. Frost Resistance

The frost resistance of Type III cement concretes was assessed by measuring mass loss of air-entrained concretes subjected to freezing and thawing cycles. Figures 5.13 and 5.14 present mass loss of the studied concretes subjected to freezing and thawing cycles at different ages of 24 hrs and 28 days, respectively. Figure 5.15 shows the ultimate mass loss of these concretes after 25 freezing and thawing cycles (each cycle consisted of 2 days of freezing and 2 days of thawing). It can be seen that the frost resistance reduced as cement factor was increased. It, however, improved (increased) as curing age was extended.

Increases in cement content negatively influenced the frost resistance of Type III cement concretes. For 24-hr tested mixtures, the ultimate mass loss increased by 5.6 and 7.1% when the cement content was increased from 550 to 650 and 650 to 750 lb/yd³, respectively. Similar increases in cement content of 28-day cured concretes resulted in 4.6 and 42.4% increases in ultimate mass loss, respectively.

It was also observed that the frost resistances of 28-day cured concretes were superior to those of 24-hr cured concretes. The ultimate mass losses of 28-day cured concretes were lower than those of 24-hr cured concretes by 34.6, 35.2 and 13.8% for cement contents of 550, 650 and 750 lb/yd³, respectively.

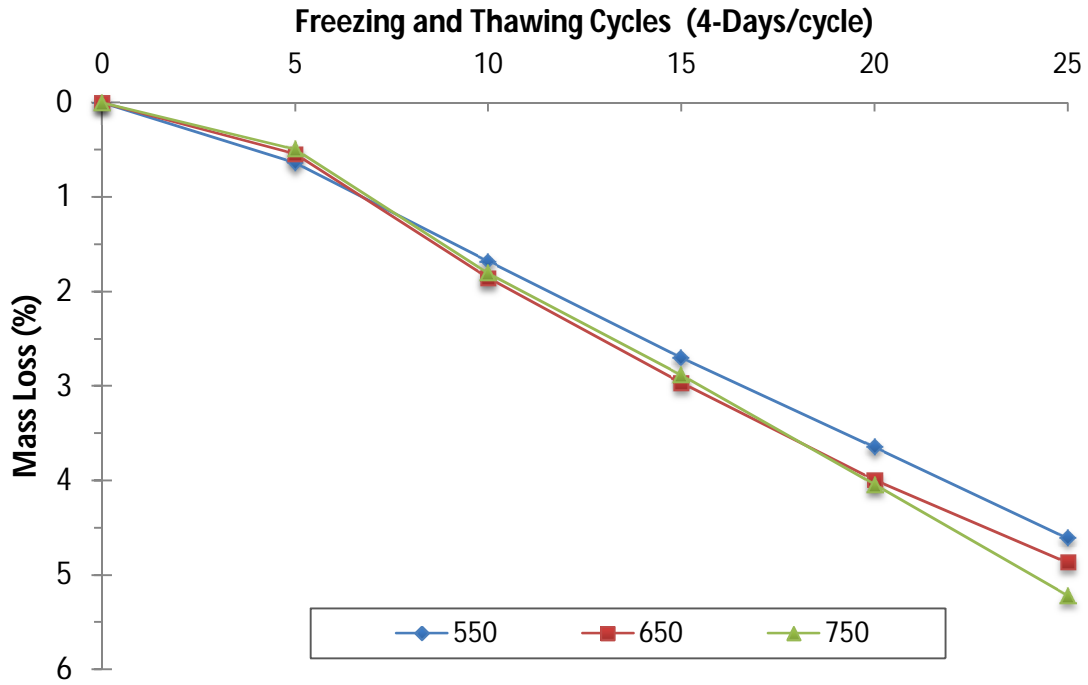

Figure 5-13: Mass Loss of Type III-HES Concretes tested at the Age of 24 Hrs

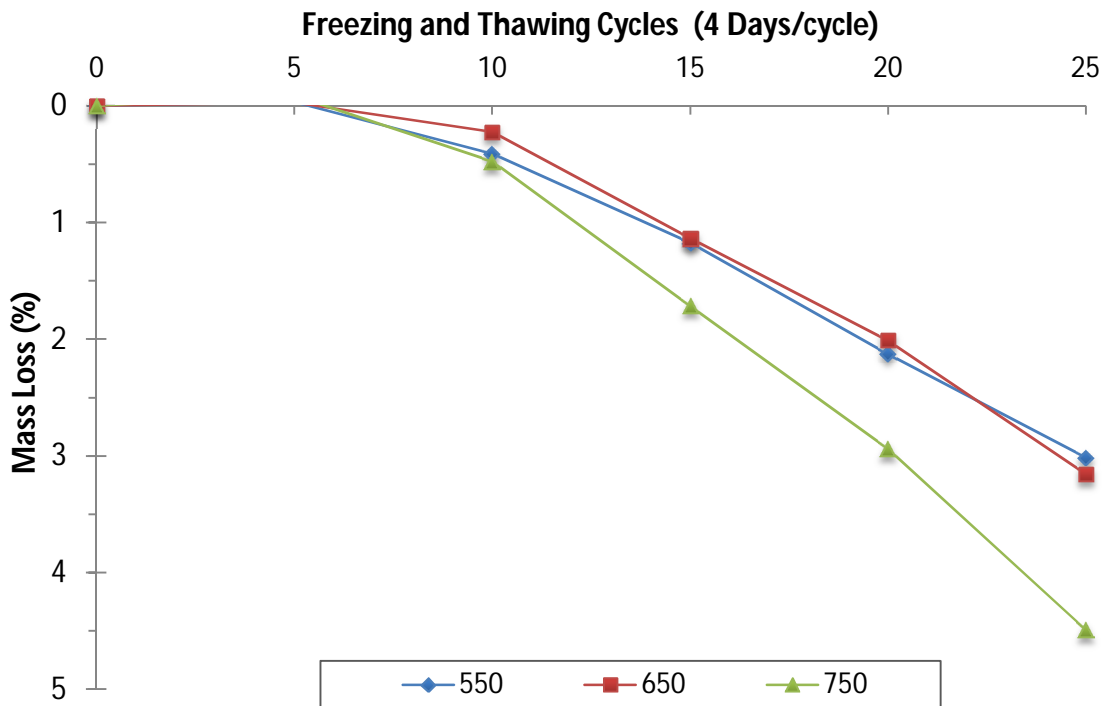

Figure 5-14: Mass Loss of Type III-HES Concretes tested at the Age of 28 Days

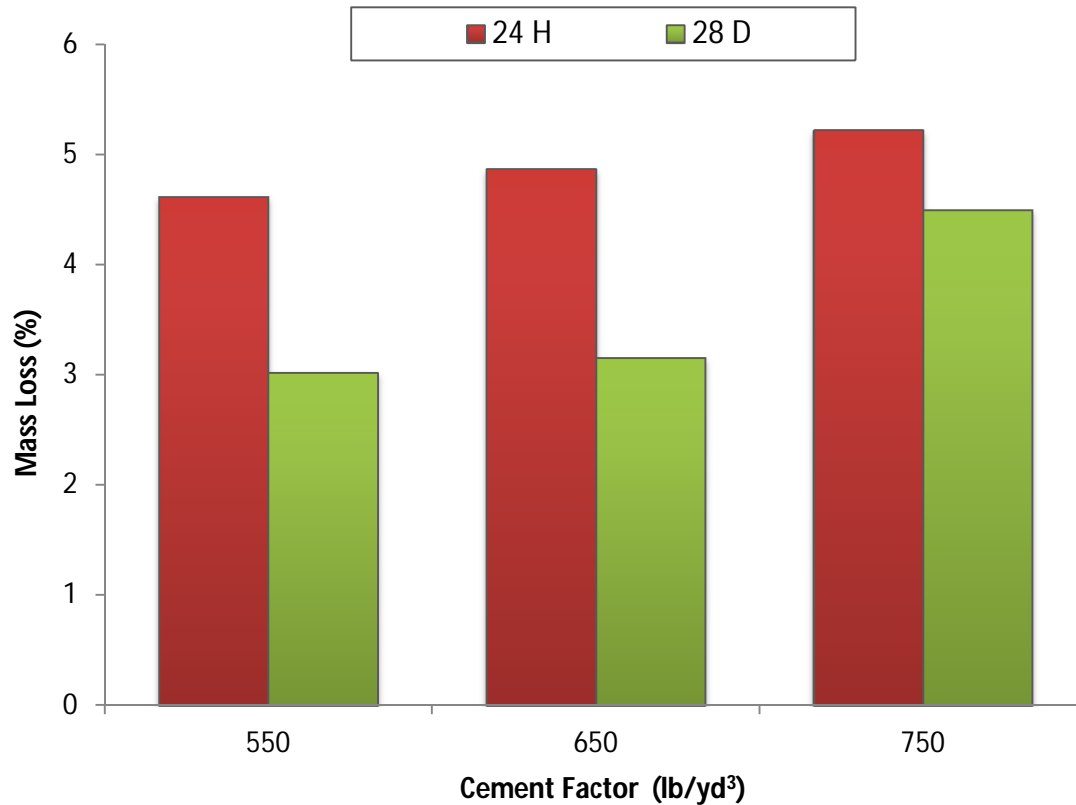

Figure 5-15: Ultimate Mass Loss of Type III-HES Concretes Subjected to 25 Freezing and Thawing Cycles

5.2.10. Abrasion

Table 5.9 reports results of abrasion test for the studied Type III cement concretes. These results are also presented in Figure 5.16. It can be seen that overall, the abrasion depths slightly increased when cement content was increased. The abrasion depths, however, reduced when curing age was increased.

Effects of cement factor on abrasion resistance of Type III cement concretes were negligible. On average, the abrasion depth of 24-hr and 28-day cured concretes increased by 1.1 and 5.1% for each 100 lbs increase in the cement content, respectively.

Abrasion resistance increased with increases in curing age. As curing age was extended from 24 hrs to 28 day, the abrasion depth reduced by 19.4, 16.4 and 12.9% for concretes with cement factors of 550, 650 and 750 lb/yd³, respectively.

Table 5-9: Abrasion Depth of Type III-HES Concretes

Age	Cement Factor (lb/yd ³)		
	550	650	750
Abrasion Depth (mm)			
24 hrs	0.8165	0.8255	0.8343
28 days	0.6578	0.6903	0.7269
Abrasion Depth (in)			
24 hrs	0.0321	0.0325	0.0328
28 days	0.0259	0.0272	0.0286

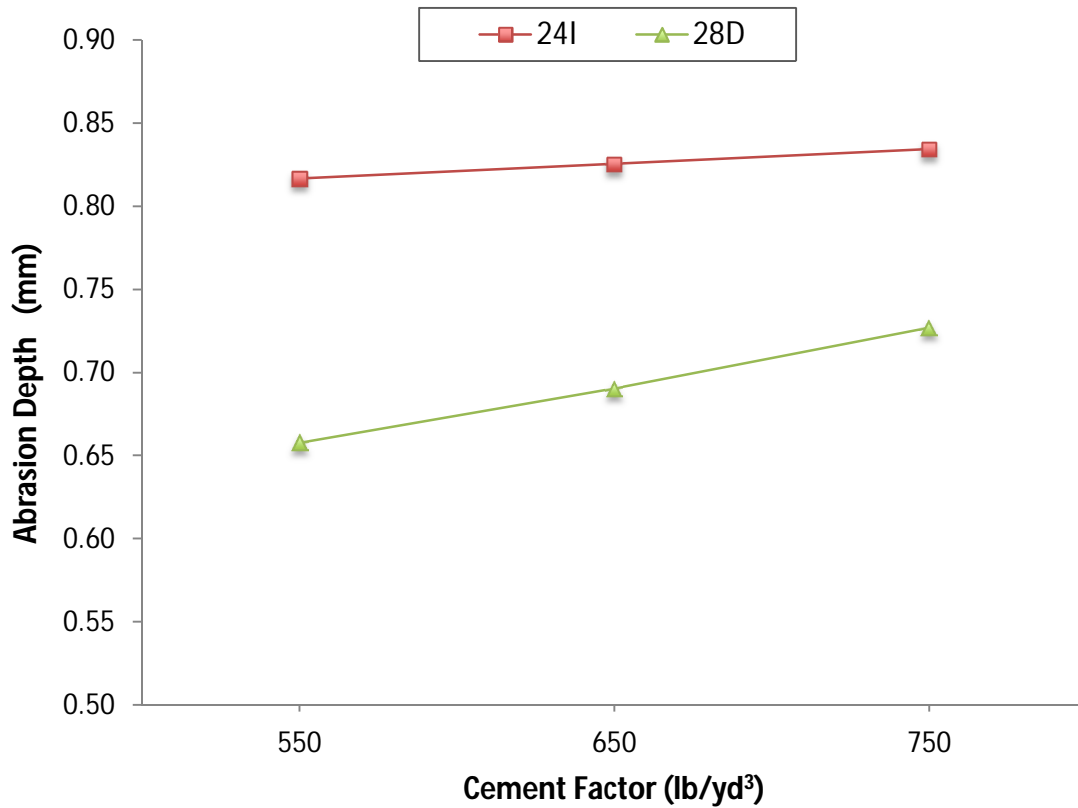

Figure 5-16: Abrasion Depth of Type III-HES Concretes

Chapter 6 Hardened Properties of High Early-Age Strength Rapid Set Cement Concretes

6.1. Introduction

The third phase of this study dealt with evaluation of different properties of high early-age strength Rapid Set cement concretes. The three different variables considered for this phase of study were as follows:

- *Cement factor (cement content):*

Two different cement contents of 550 and 650 lb/yd³ were considered for this phase of study.

- *Use of air-entraining admixture:*

In order to assess effects of air-entrainment on hardened properties of high early-age strength Rapid Set cement concretes, the designed concretes were made with and without air-entraining admixture.

- *Curing age:*

Effects of curing age on the properties of high early-age strength Rapid Set cement concretes were studied by testing hardened concretes at their opening time, 24 hrs, and 28 days.

6.2. Results and Discussion

Similar to the first and second phases of this study, a comprehensive experimental program was devised to assess hardened properties of high early-age strength Rapid Set cement concretes including mechanical properties (compressive and flexural strengths), transport properties (absorption, water permeability, rapid chloride penetration, and rapid chloride migration), durability properties (frost resistance, chloride induced corrosion, and resistance to wear), and dimension stability (drying shrinkage). As mentioned earlier, three testing ages, depending on the property tested, were considered at opening time, 24 hrs, and 28 days.

6.2.1. Compressive Strength

Table 6.1 presents results of compressive strength test for the studied high early-age strength Rapid Set cement concretes at different curing ages including opening time, 24 hrs and 28 days. Table 6.2 reports the opening times and range of compressive strengths at opening times. Effects of dominant variables on the compressive strength and opening time of the studied Rapid Set cement concretes are discussed below.

6.2.1.1. Effects of Cement Content

Figure 6.1 presents the opening time of Rapid Set cement concretes. It can be seen that the opening time of Rapid Set cement concretes was not affected by the cement factor. The opening time of the studied concretes (with and without air entrainment) were similar and equal to an hour for both cement contents of 550 and 650 lb/yd³.

Effect of cement factor on the 24-hr and 28-day compressive strengths of Rapid Set cement concretes is presented in Figure 6.2. It can be seen that overall, the compressive strength of Rapid Set cement concretes marginally reduced with increases in cement content. On average, the 24-hr and 28-day compressive strength reduced by 4.2 and 2.0% when the cement factor was increased from 550 to 650 lb/yd³, respectively.

Table 6-1: Compressive Strength of Rapid Set HES Concretes (psi)

Mixture Identification		Testing Time		
		Opening Time	24 hrs	28 days
Rapid Set	550	4768	8736	10970
	AE-550	4051	7286	8133
	650	4737	8768	10724
	AE-650	3603	6641	7988

* AE: Air-entrained

Table 6-2: Opening Time of Rapid Set HES Concretes and Range of Compressive Strengths at Opening Times

Mixture Identification		Compressive Strength (psi)			Opening Time (hrs)	
		Minimum	Average	Maximum	Non Air-Entrained	Air-Entrained
Rapid Set	550	4253	4768	5230	1	
	AE-550	3797	4051	4235		1
	650	4278	4737	5108	1	
	AE-650	3348	3603	3797		1

* AE: Air-entrained

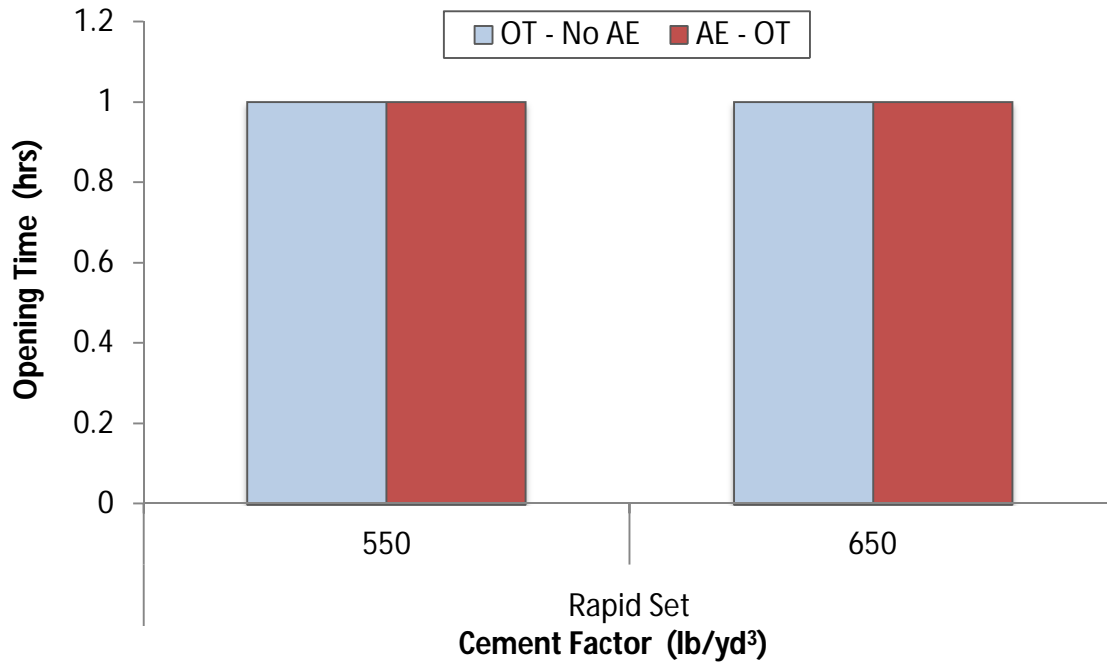

Figure 6-1: Opening Time of Rapid Set HES Concretes

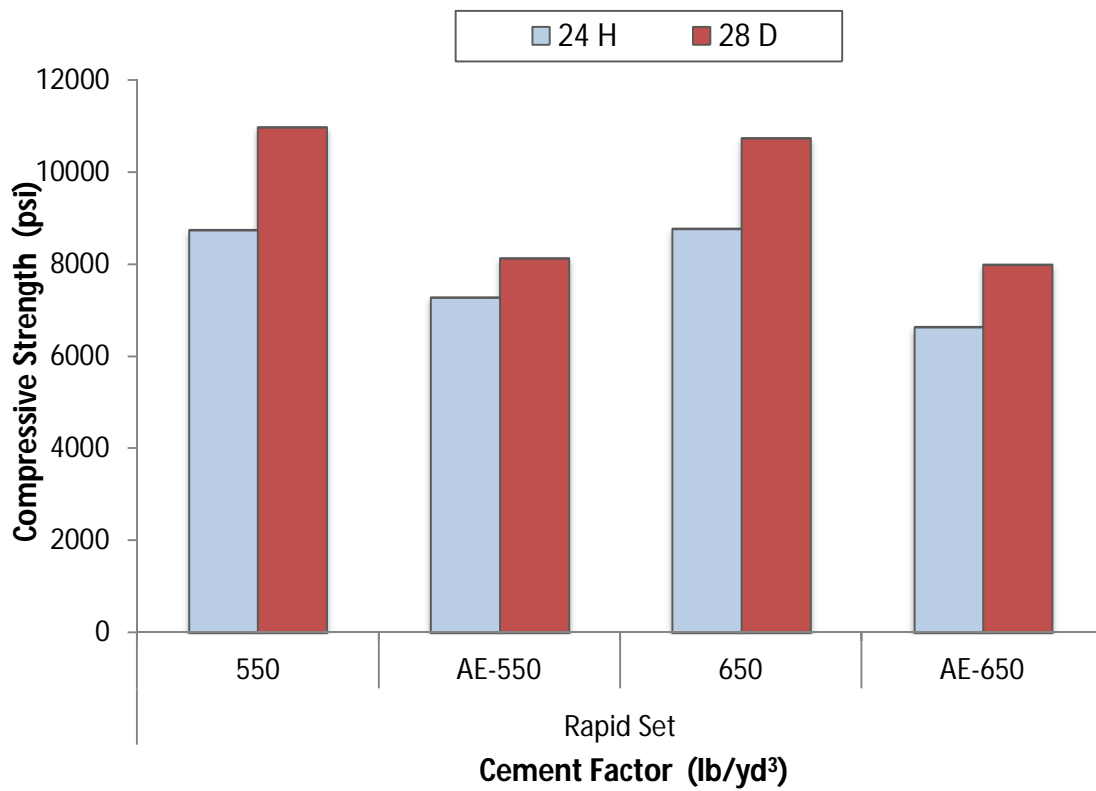

Figure 6-2: Compressive Strength Rapid Set HES Concretes at 24 Hrs and 28 Days

6.2.1.2. Effects of Air-Entraining Admixture

Figure 6.1 also shows effects of air-entraining admixture on the opening time of Rapid Set cement concretes. It can be seen that the opening times didn't change when air-entraining admixture was added to the mixtures. The opening times of all concretes with and without air-entrainment were similar and equal to an hour.

Figure 6.2 presents the effect of air entrainment on the compressive strength of the studied Rapid Set cement concretes. It can be seen that the compressive strength significantly reduced when air-entraining admixture was added to the mixtures. Inclusion of air-entraining admixture reduced the 24-hr compressive strengths by 16.6 and 24.3% for mixtures with cement factors of 550 and 650 lb/yd³, respectively. Similarly, addition of air-entraining admixture resulted in averagely 25.9 and 25.5% reduction in the 28-day compressive strength of concretes made with cement factors of 550 and 650 lb/yd³, respectively.

6.2.1.3. Effects of Curing Age

Effect of curing age on the compressive strength of Rapid Set cement concretes can also be seen in Figure 6.2. Overall, the strength developments of Rapid Set cement concretes were quick due to the nature of this cement. On average, the opening time and 24-hr compressive strengths of the studied Rapid Set cement concretes were about 46 and 84% of their 28-day compressive strengths, respectively.

6.2.2. Flexural Strength

Table 6.3 presents results of flexural strength for the studied high early-age strength Rapid Set cement concretes at different curing ages, including opening times, 24 hrs and 28 days. These results are also shown in Figure 6.3. It can be seen that the flexural strength of the studied concretes were in the range of 775 to 800 psi at their opening times. All the tested samples had flexural strengths of higher than 640 psi at their opening times.

The flexural strengths of Rapid Set cement concretes were almost similar for the two cement contents of 550 and 650 lb/yd³. While the 24-hr flexural strengths increased by 3.4% when the cement factor was increased from 550 to 650 lb/yd³, the same increases in the cement content reduced the 28-day flexural strengths by 1.9%.

The studied concretes developed majority of their flexural strength within the first day due to nature of Rapid Set cement. On average, the opening time and 24-hr flexural strengths of the studied Rapid Set cement concretes were about 67 and 89% of their 28-day flexural strengths, respectively.

Table 6-3: Flexural Strength of Rapid Set HES Concretes

Mixture Identification	Testing Age	Flexural Strength (psi)			
		Average	Maximum	Minimum	
Rapid Set	550	Opening time	799	849	731
		24 hr	1032	1124	919
		28 day	1193	1419	1020
	650	Opening time	775	829	644
		24 hr	1067	1224	925
		28 day	1170	1264	1008

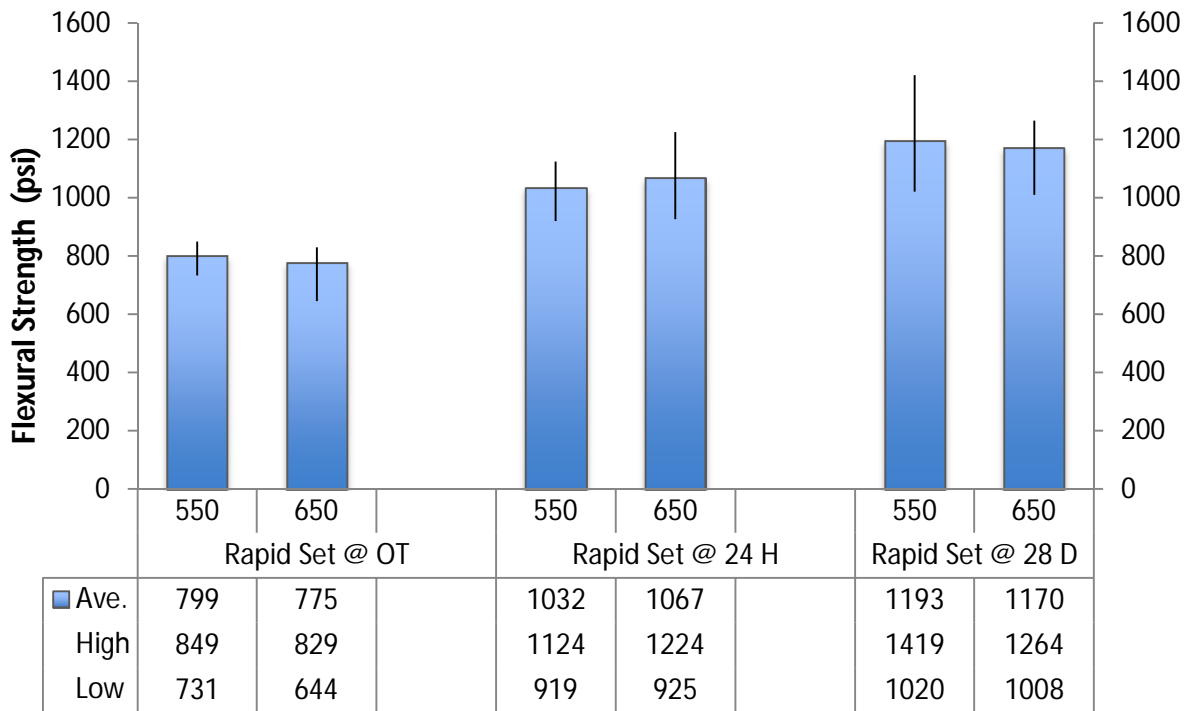

Cement Factor (lb/yd³) and Curing Age

Figure 6-3: Flexural Strength of Rapid Set HES Concretes

6.2.3. Absorption and Volume of Permeable Voids

Table 6.4 presents results of absorption test for the studied high early-age strength Rapid Set cement concretes. The effects of dominant variables on the absorption and volume of permeable voids of the studied concretes are discussed below.

Table 6-4: Results of Absorption for Rapid Set HES Concretes

Mixture Identification	Testing Age	Absorption After Immersion (%)	Absorption After Immersion & Boiling (%)	Volume of Permeable Voids (%)	
Rapid Set	550	Opening time	3.75	3.98	9.59
		24 hrs	3.90	4.05	9.75
		28 days	3.23	3.35	8.08
	AE - 550	Opening time	4.20	4.47	10.39
		24 hrs	4.17	4.44	10.32
		28 days	3.83	4.00	9.26
	650	Opening time	4.83	4.61	10.96
		24 hrs	4.39	4.57	10.62
		28 days	3.77	3.90	9.33
	AE - 650	Opening time	5.16	5.47	12.46
		24 hrs	4.85	5.14	11.77
		28 days	4.08	4.27	9.82

* AE: Air-entrained

6.2.3.1. Effects of Cement Content

Figure 6.4 shows absorption and volume of permeable voids of high early-age strength Rapid Set cement concretes tested at different ages of curing including opening times, 24 hrs and 28 days. It can be seen that the absorption and void contents of the studied concretes increased as cement content was increased.

For non air-entrained concretes, increases in the cement factor from 550 to 650 lb/yd³ increased the absorption of concretes tested at opening time, 24 hrs and 28 days by 28.8, 12.6 and 16.7%, respectively. A similar increase in cement content led to 14.3, 8.9

and 15.5% increases in voids contents of concretes tested at opening time, 24 hrs and 28days, respectively.

In the case of air-entrained concretes, increases in the cement content from 550 to 650 lb/yd³ increased opening time, 24-hr and 28-day absorptions by 22.9, 16.3 and 6.5%, respectively. A similar increase in cement content of these concretes resulted in 19.9, 14.1 and 6.0% increases in opening time, 24-hr and 28-day void contents, respectively.

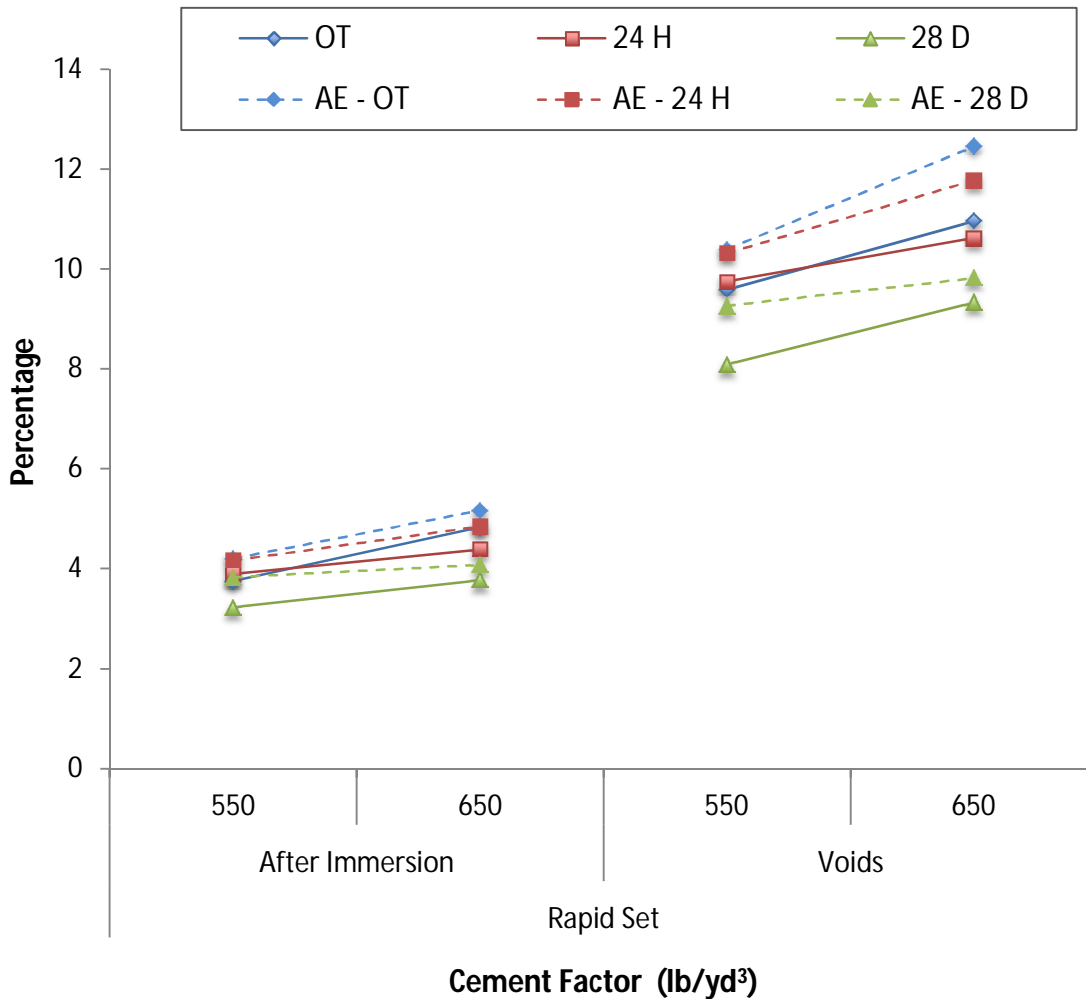

Figure 6-4: Absorption and Volume of Permeable Voids Rapid Set HES Concretes

6.2.3.2. Effects of Air-Entraining Admixture

Figure 6.4 also presents effects of air-entraining admixture on the absorption and volume of permeable voids of Rapid Set cement concretes. It can be seen that the absorption and void contents increased when air-entraining admixture was added to the mixtures.

Inclusion of air-entraining admixture increased absorption of Rapid Set cement concretes by averagely 9.4, 8.7 and 13.4% for concretes tested at opening time, 24 hrs and 28 days, respectively. For similar testing ages and the same concretes, the void contents increased by averagely 11.0, 8.3 and 9.9%, respectively, when air-entraining admixture was added.

6.2.3.3. Effects of Curing Age

Effects of curing age on the absorption and void contents of the studied concretes are also shown in Figure 6.4. It can be seen that the absorption and void contents reduced as the curing age was increased. This was particularly seen when the curing age was extended to 28 days. On average, the absorption reduced by 3.0 and 13.8% when curing age was extended from opening time to 24 hrs and 24 hrs to 28 days, respectively. For similar extensions of curing age, the void contents reduced by averagely 1.9 and 14.0%, respectively.

6.2.4. Rapid Chloride Penetration Test

Table 6.5 and Figure 6.5 document results of rapid chloride penetration test (RCPT) for the studied high early-age strength Rapid Set cement concretes tested at two

curing ages of 24 hrs and 28 days. The effects of dominant variables on the passing charges are discussed below.

Table 6-5: Passing Charge of Rapid Set HES Concretes

Mixture Identification	Testing Time	Passing Charges (Coulombs)			
		Average	Maximum	Minimum	
Rapid Set	550	24 hrs	1345	1489	1227
		28 days	577	628	494
	AE - 550	24 hrs	1576	1901	1419
		28 days	548	579	524
	650	24 hrs	1568	1742	1304
		28 days	723	826	627
	AE - 650	24 hrs	1882	2216	1683
		28 days	662	737	559

* AE: Air-entrained

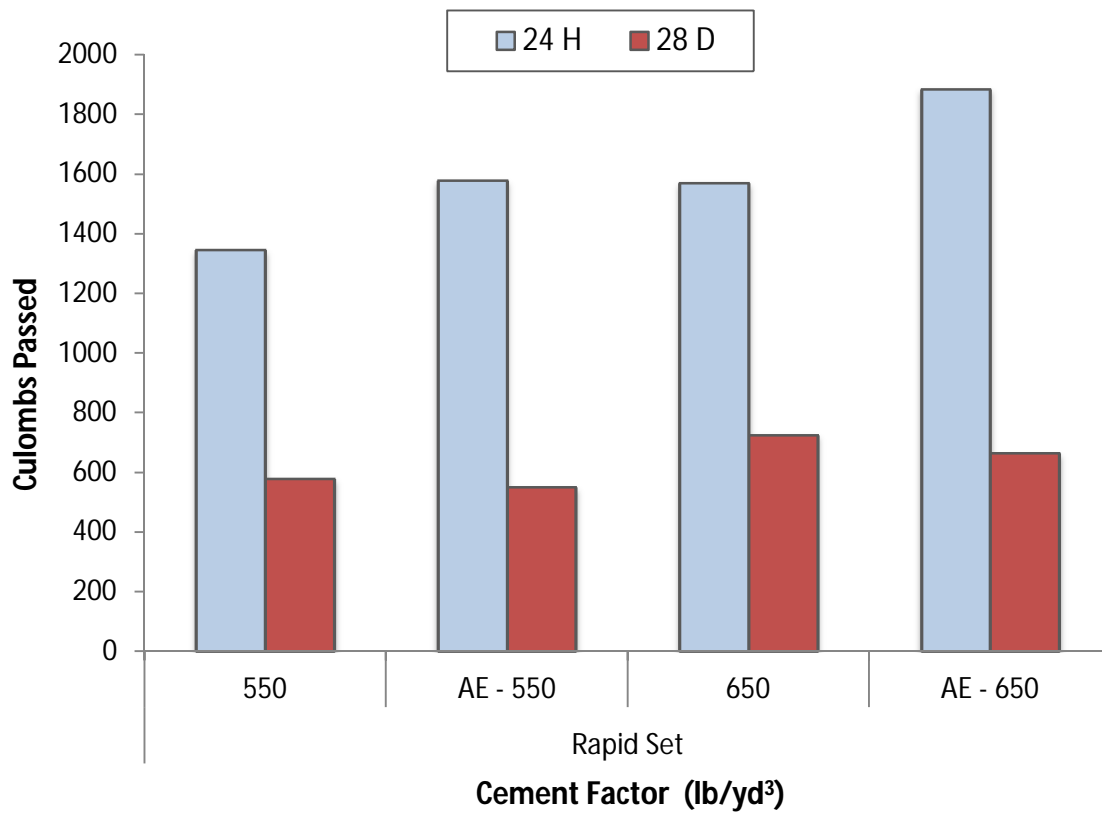

Figure 6-5: Passing Charge of Rapid Set HES Concretes

6.2.4.1. Effects of Cement Content

Figure 6.5 presents effects of cement factor on the passing charges of Rapid Set cement concretes. It can be seen that similar to the other cement types, the passing charges increased as cement content was increased.

For non air-entrained concretes, the 24-hr and 28-day passing charges increased by 16.6 and 25.3% when the cement factor was increased from 550 to 650 lb/yd³, respectively. In the case of air-entrained concretes, a similar increase in the cement factor resulted in 19.4 and 20.8% increases in the 24-hr and 28-day passing charges, respectively.

6.2.4.2. Effects of Air-Entraining Admixture

Figure 6.5 also presents effects of air-entraining admixture on the passing charges of Rapid Set cement concretes. It can be seen that the passing charges of 24-hr cured concretes increased when air-entraining admixture was added to the concrete mixtures, whereas an opposite trend was seen for 28-day cured concretes.

For concretes with cement contents of 550 and 650 lb/yd³, air entrainment resulted in 17.2 and 20% increases in the 24-hr passing charges, respectively. For similar cement factors, addition of air-entraining admixture reduced the 28-day passing charges by 5.0 and 8.4%, respectively.

6.2.4.3. Effects of Curing Age

Figure 6.5 also shows effect of curing age on the results of RCPT test. It can be seen that the passing charges significantly reduced as curing age was increased from 24 hrs to 28 days. The 28-day passing charges of Rapid Set cement concretes were 54 to 65% (with an average of 60%) lower than their 24-hr passing charges.

6.2.5. Rapid Chloride Migration Test

Similar to the other types of cement, rapid chloride migration test was also conducted on Rapid Set cement concretes. Figure 6.6 shows a sample of concrete sample after silver nitrate sprayed on its surface. It can be seen that the entire sample changed color to white or purple. Considering this observation, it could be concluded that chloride penetrated all the way in the Rapid Set cement concretes which had not been expected cause of their performance in other experiments such as RCPT. After consulting with the Rapid Set cement producer, it was decided to not proceed with RMT for Rapid Set cement concretes until further investigations have been done; in particular on bonded versus free chloride ions in alumina-based cements.

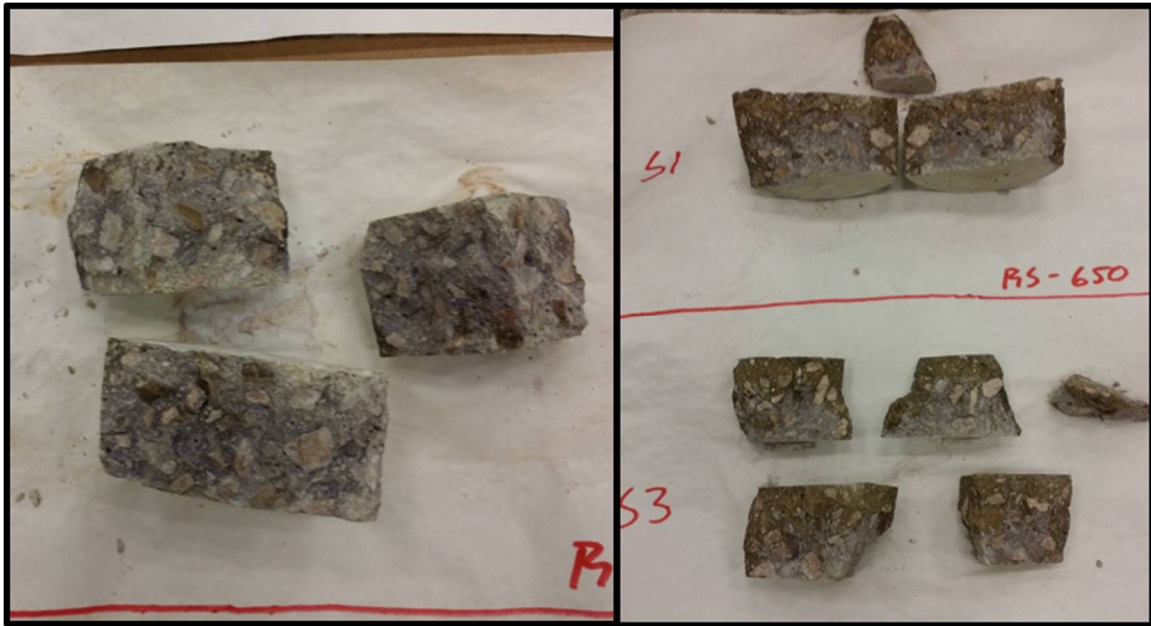

Figure 6-6: Rapid Set HES Concrete Samples Subjected to Rapid Chloride Migration Test (After Spraying Silver Nitrate)

6.2.6. Water Permeability

Table 6.6 and Figure 6.7 show results of water penetration depth for the studied Rapid Set cement concretes tested at the ages of 24 hrs and 28 days. It can be seen that the depth of penetration slightly increased as cement content was increased. When cement content was increased from 550 to 650 lb/yd³, the 24-hr and 28-day water penetration depths increased by 2.0 and 6.8%, respectively.

The depth of water penetration considerably reduced as curing age was increased. On average, the 28-day water penetration depths of Rapid Set cement concretes were about 77% lower than their 24-hr water penetration depths.

Table 6-6: Water Penetration Depth of Rapid Set HES Concretes

Age	Cement Factor (lb/yd ³)	
	550	650
	Water Penetration Depth (mm)	
24 hrs	16.322	16.648
28 days	3.604	3.848
	Water Penetration Depth (in)	
24 hrs	0.6426	0.6554
28 days	0.1419	0.1515

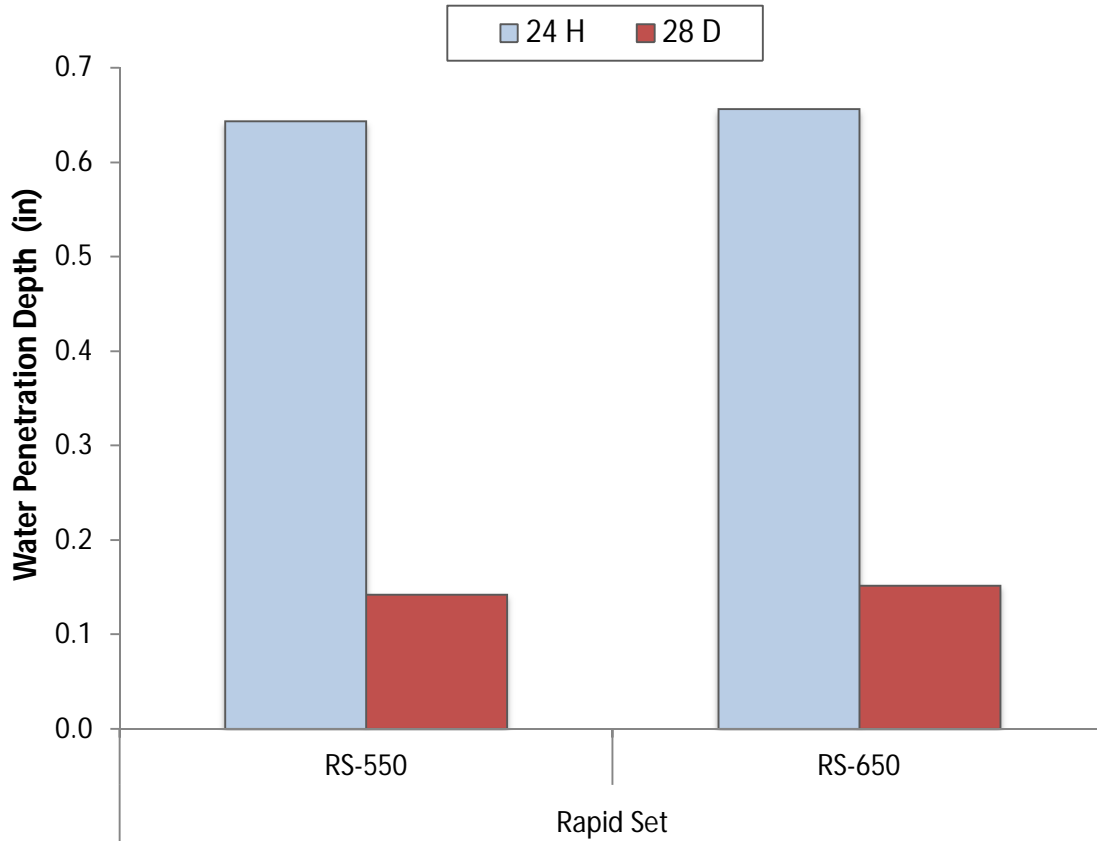

Figure 6-7: Water Penetration Depth of Rapid Set HES Concretes

6.2.7. Drying Shrinkage

Figures 6.8 through 6.10 show drying shrinkage of Rapid Set cement concretes for samples transferred to the shrinkage room at the ages of their opening time, 24 hrs and 28 days, respectively. Effects of cement content and curing age were studied on the drying shrinkage of Rapid Set cement concretes, which discussed in the following subsections.

6.2.7.1. Effects of Cement Content

Figures 6.8 through 6.10 present effects of cement factor on the drying shrinkage of Rapid Set cement concretes. Figure 6.11 presents the ultimate drying shrinkage of Rapid Set cement concretes kept in shrinkage room for 7.5 months. It can be seen that increases in cement content increased the drying shrinkage of concretes transferred to shrinkage room at their opening time, whereas a contrary was seen for concretes transferred to shrinkage room at the ages of 24 hrs and 28 days.

For concretes transferred to shrinkage room at their opening time, the drying shrinkage increased by about 23% when the cement factor was increased from 550 to 650 lb/yd³. On the other hand, a similar increase in cement content resulted in about 13 and 15% reduction in the drying shrinkage of 24-hr and 28-day cured concretes, respectively.

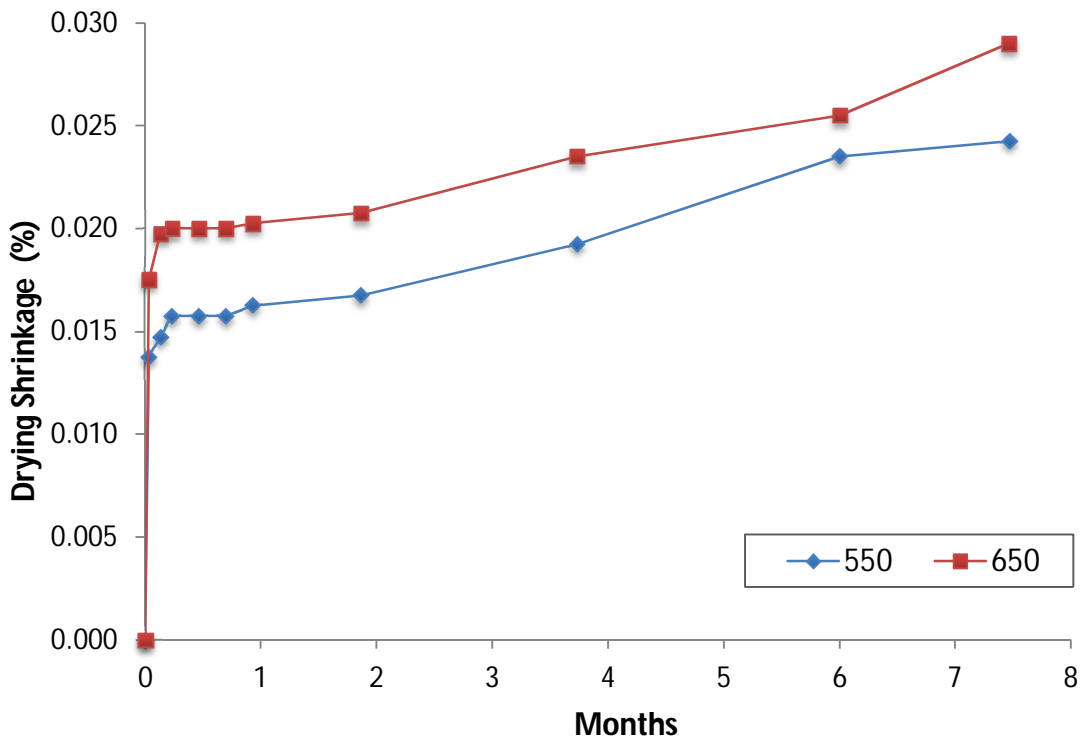

Figure 6-8: Drying Shrinkage of Rapid Set HES Concretes Transferred to Shrinkage Room at Opening Time

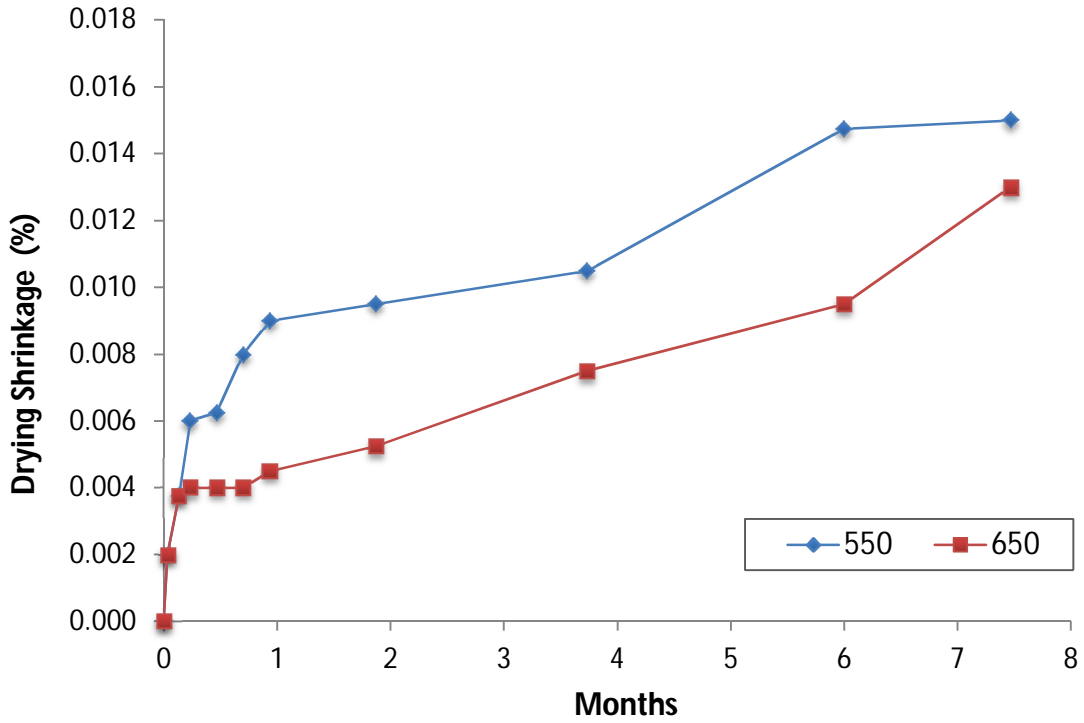

Figure 6-9: Drying Shrinkage of Rapid Set HES Concretes Transferred to Shrinkage Room at the Age of 24 Hrs

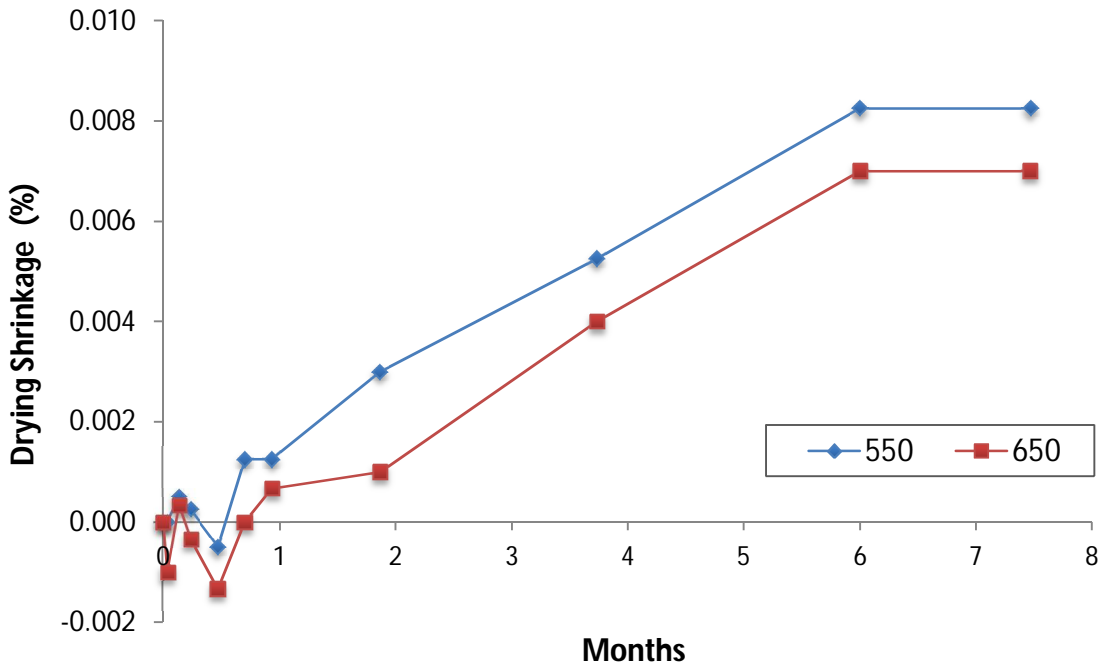

Figure 6-10: Drying Shrinkage of Rapid Set HES Concretes Transferred to Shrinkage Room at the Age of 28 Days

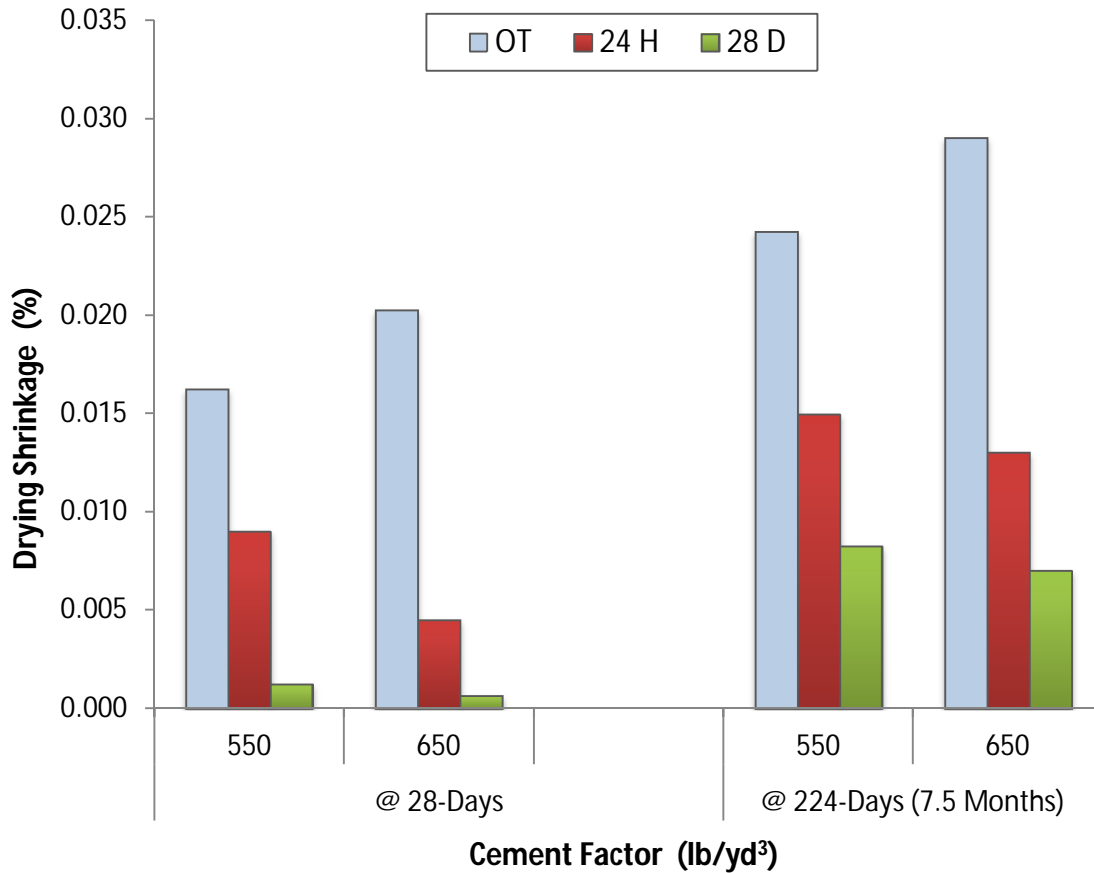

Figure 6-11: The Drying Shrinkage of Rapid Set HES Concretes After 28 Days and 7.5 Months in Shrinkage Room

6.2.7.2. Effects of Curing Age

Figure 6.11 also shows effect of curing age on the drying shrinkage of Rapid Set cement concretes. It can be seen that the drying shrinkage reduced as curing age was increased. The drying shrinkage of 28-day cured concretes were averagely 45.7 and 70.5% lower than the drying shrinkage of concretes transferred to shrinkage room at 24 hrs and opening time, respectively.

6.2.7.3. Comparison with NDOT Specification

The drying shrinkage of Rapid Set cement concretes were also compared with NDOT specification limit of 0.06% (after 28 days in shrinkage room). This comparison is also shown in Figure 6.11. It can be seen all the studied concretes had significantly lower drying shrinkage than the specification limit. The highest drying shrinkage of Rapid Set cement concretes is about 1/3 (one-third) of the specification limit.

6.2.8. Corrosion Resistance

Table 6.7 and Figure 6.12 present failure time of the studied Rapid Set cement concretes in corrosion test. It can be seen that overall the corrosion resistance reduced (failure time reduced) as cement content was increased. The 24-hr and 28-day failure time reduced by 7.1 and 17.6% when the cement factor was increased from 550 to 650 lb/yd³, respectively.

The corrosion resistance slightly improved as curing age was extended. The 28-day failure times of Rapid Set cement concretes were 21.4 and 7.6% more than their 24-hr failure times for mixtures with cement contents of 550 and 650 lb/yd³, respectively.

Table 6-7: Time to Failure of Rapid Set HES Concretes in Corrosion Test

Mixture Identification	Curing Age	Failure Time (days)	
Rapid Set	550	24 hrs	3.5
		28 days	4.25
	650	24 hrs	3.25
		28 days	3.5

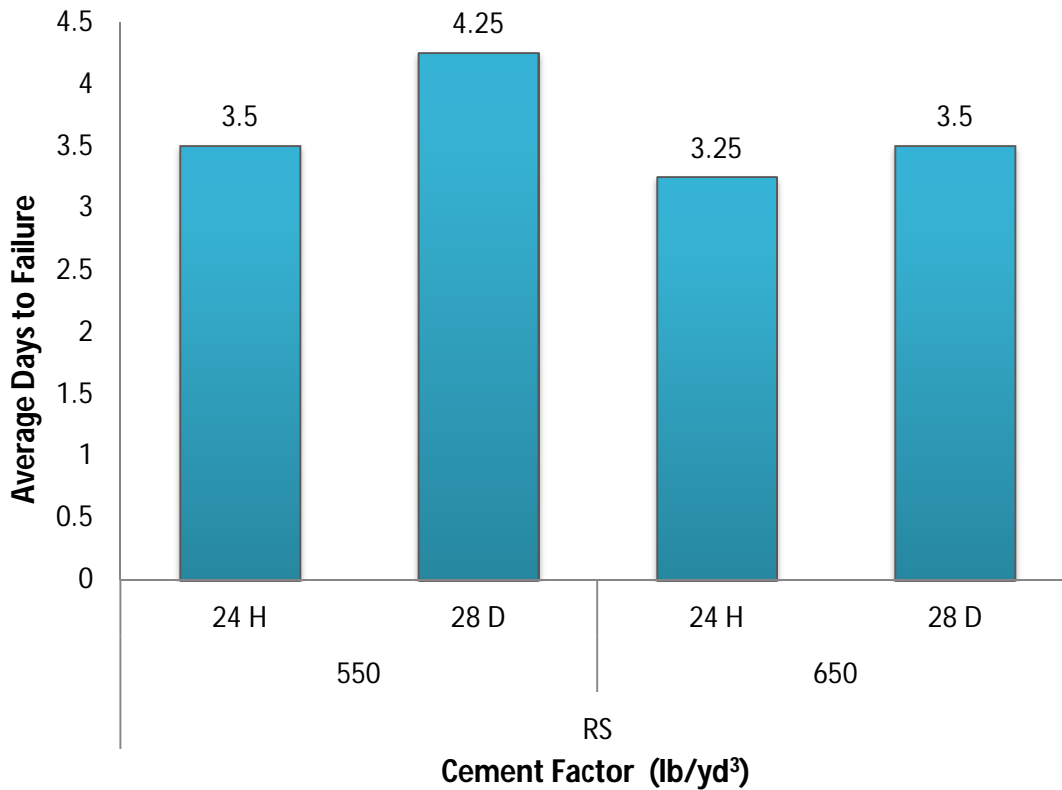

Figure 6-12: Time to Failure of Rapid Set HES Concretes in Corrosion Test

6.2.9. Frost Resistance

The frost resistance of Rapid Set cement concretes was assessed by measuring mass loss of air-entrained concretes subjected to freezing and thawing cycles. Figures 6.13 and 6.14 present mass loss of the studied concretes subjected to freezing and thawing cycles at different ages of 24 hrs and 28 days, respectively. Figure 6.15 shows the ultimate mass loss of these concretes after 25 freezing and thawing cycles (each cycle consisted of 2 days of freezing and 2 days of thawing).

It can be seen that the frost resistance reduced as cement factor was increased. The ultimate mass loss of 24-hr and 28-day cured concretes increased by 11.0 and 11.3% when the cement content was increased from 550 to 650 lb/yd³, respectively.

It was also observed that the frost resistances of 28-day cured concretes were superior to those of 24-hr cured concretes. The ultimate mass loss of 28-day cured concretes was averagely 31.5% lower than those of 24-hr cured concretes.

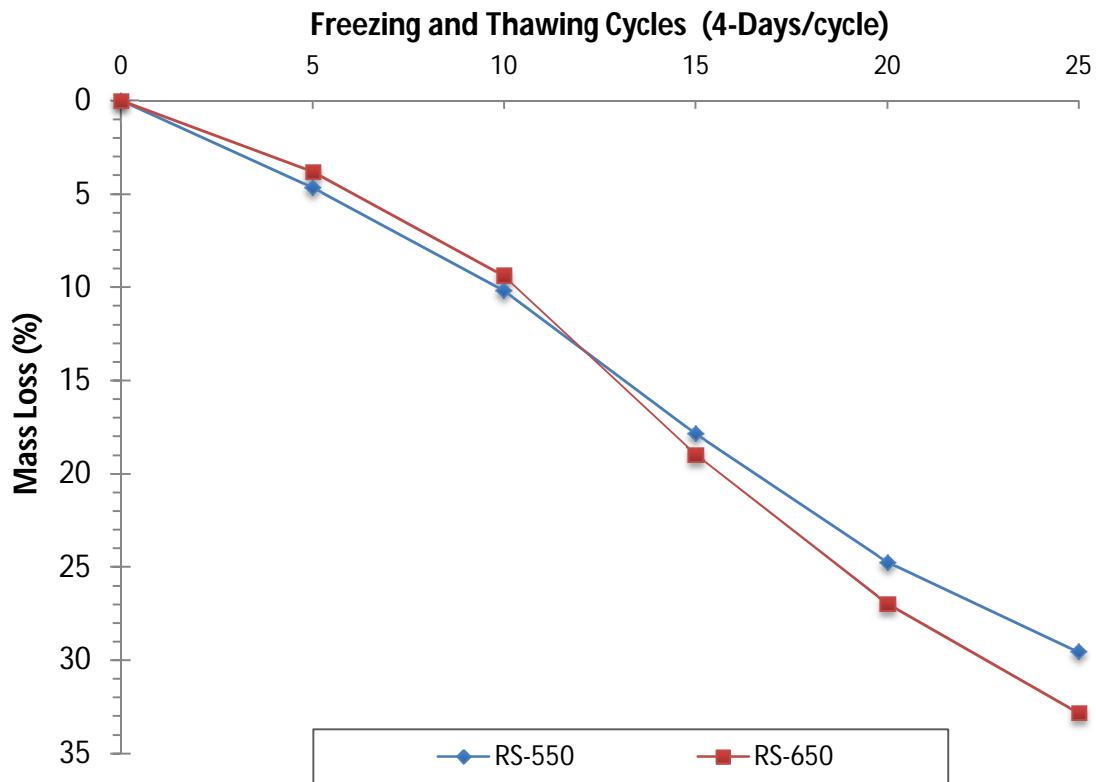

Figure 6-13: Mass Loss of Rapid Set HES Concretes Tested at the Age of 24 Hrs

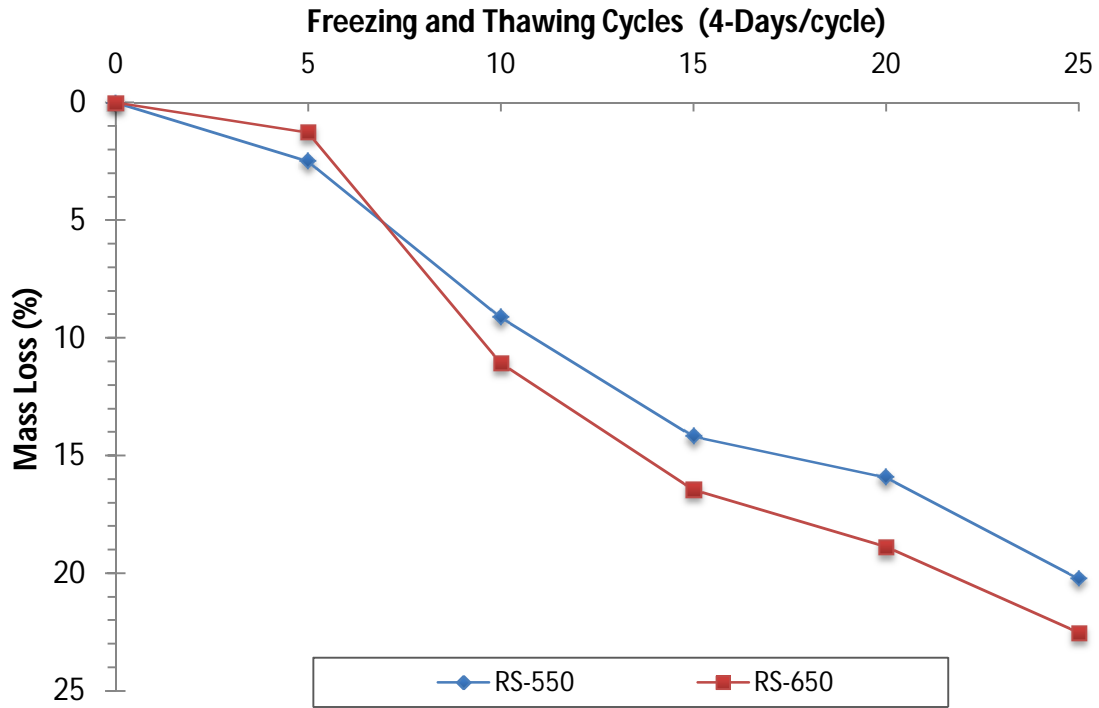

Figure 6-14: Mass Loss of Rapid Set HES Concretes Tested at the Age of 28 Days

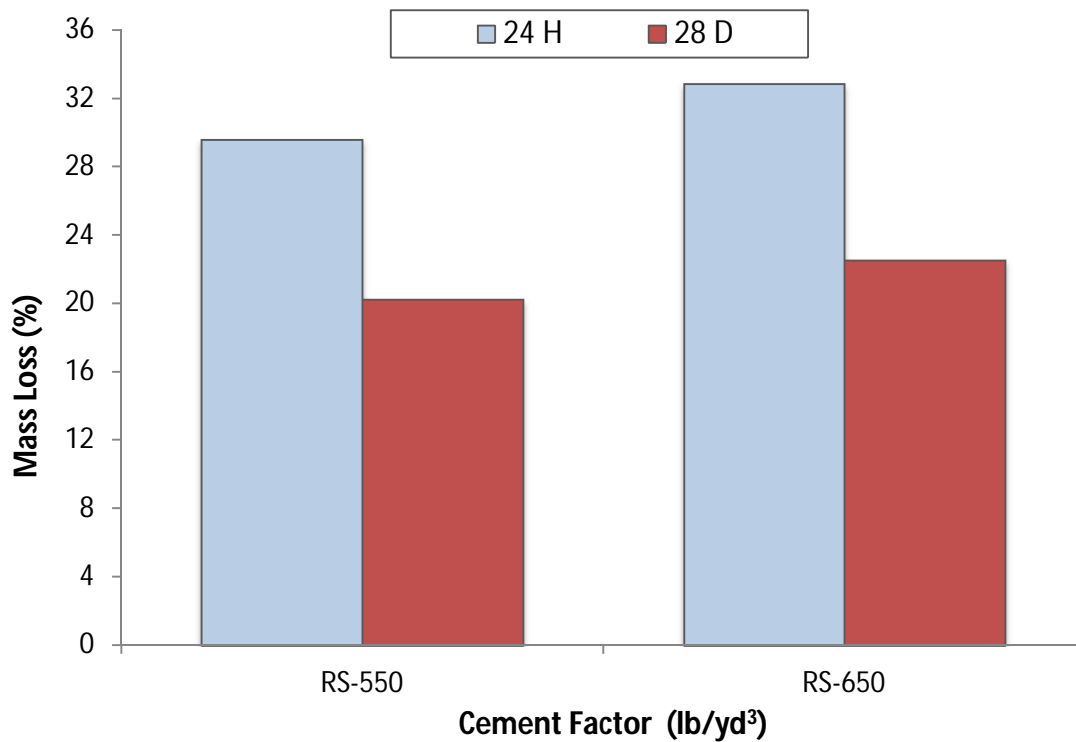

Figure 6-15: Ultimate Mass Loss of Rapid Set HES Concretes Subjected to 25 Freezing and Thawing Cycles

6.2.10. Abrasion

Table 6.8 documents results of abrasion test for the studied Rapid Set cement concretes. These results are also presented in Figure 6.16. It can be seen that the abrasion depths of concretes with different cement factors were almost similar. In fact, effects of cement factor on abrasion resistance of Rapid Set cement concretes were negligible. When the cement content was increased from 550 to 650 lb/yd³, the abrasion depth of 24-hr and 28-day cured concretes reduced by 0.4 and 2.1%, respectively.

The abrasion depth significantly reduced with increases in curing age. As curing age was extended from 24 hrs to 28 day, the abrasion depth reduced (abrasion resistance increased) by averagely about 44%.

Table 6-8: Abrasion Depth of Rapid Set HES Concretes

Age	Cement Factor (lb/yd ³)	
	550	650
	Abrasion Depth (mm)	
24 hrs	1.1129	1.1080
28 days	0.6306	0.6175
	Abrasion Depth (in)	
24 hrs	0.0438	0.0436
28 days	0.0248	0.0243

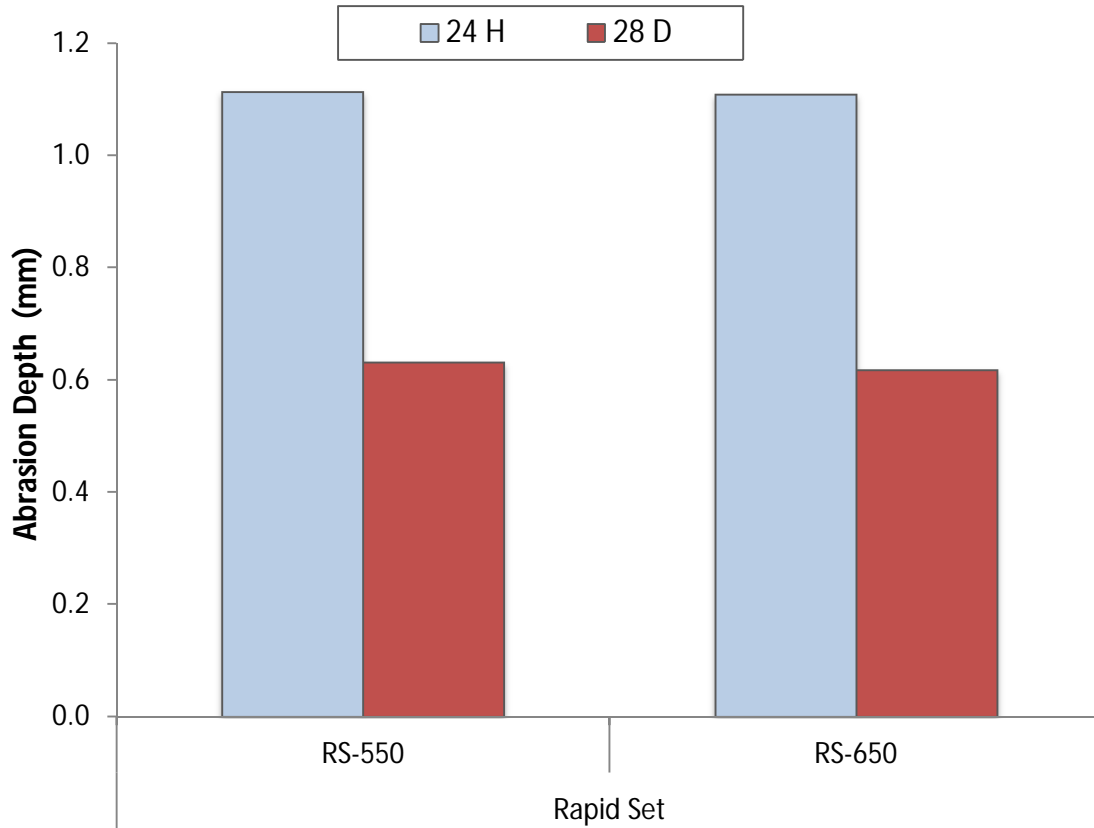

Figure 6-16: Abrasion Depth of Rapid Set HES Concretes

6.3. Concluding Remark

In view of the above-mentioned results pertaining to strength, transport, volume stability, and durability properties of the studied high early-age strength Rapid Set cement concretes, an increase in cement factor beyond 550 lb/yd³ adds little benefits while increasing the overall cost of repaired products.

Chapter 7 Comparison of High Early-Age Strength Concretes

7.1. Introduction

This chapter aims to compare the hardened properties of high early-age strength concretes made with different types of cement and a similar cement content of 650 lb/yd³. As discussed in previous chapters, high early-age strength concretes were designed with an objective of reaching a minimum compressive strength of 3000 psi in a shortest possible opening time (OT) while maintaining the manufacturer limit for admixture usage (particularly for accelerator dosage). For this reason, coupled with obligations related to workability and setting, different types of high early-age strength concretes had to be made with different water-to-cement ratio (w/c), thus confining the comparison to ranking orders. Table 7.1 presents high early-age strength concretes selected from each type of cement and their key elements of mixture design. The cement factor of 650 lb/yd³ was selected for the purpose of comparison due to two main reasons: (1) results of survey showed cement factor of 600 to 700 lb/yd³ as the most common and preferable cement content, and (2) 650 lb/yd³ was the common cement factor used in all studied high early-age strength concretes, including Type V, Type III and Rapid Set cement concretes. Two additional mixtures were also produced and included for the comparative studies. These concretes were blended cement concretes made with different proportions of Type V and Rapid Set Cements. One of them (50/50 blend) contained 50%-50% combination of Type V and Rapid Set cements, while the other one (75/25 blend) had 75% Type V cement and 25% Rapid Set cement. The studied hardened properties included mechanical properties

(compressive and flexural strengths), transport properties (absorption, water permeability, rapid chloride penetration, and rapid chloride migration), durability properties (frost resistance, chloride induced corrosion, and resistance to wear), and dimensional stability (drying shrinkage).

Table 7-1: Key Elements of Mixture Design, Fresh Properties, and Opening Time of the Selected HES Concretes

Mixture Identification	w/c	Accelerator Dosage (%)	Initial Setting Time (min)	Final Setting Time (min)	Opening Time (hrs)	Compressive Strength at Opening Time (psi)	
Portland Cement	V-2.0	0.275	2.0	87	167	6.5	3575
	AE-V-2.0	0.275	2.0	-	-	8.5	3278
	V-2.8	0.275	2.8	-	-	5.5	3138
	AE-V-2.8	0.275	2.8	-	-	7.5	3376
	III	0.35	2.0	70	129	5.0	3421
	AE-III	0.35	2.0	-	-	6.0	3770
CSA Cement	RS	0.40	-	20*	30*	1.0	4737
	AE-RS	0.40	-	20*	30*	1.0	3603
Type V PC / CSA Blend	50/50	0.338	-	20*	30*	1.0	3801
	AE-50/50	0.338	-	20*	30*	1.5	3569
	75/25	0.306	-	20*	30*	5.5	3330
	AE-75/25	0.306	-	20*	30*	6.5	3324

* Setting times of Rapid Set cement was provided by manufacturer

** AE: Air –entrained

*** All the selected concretes had cement factor of 650 lb/yd³

7.2. Properties

7.2.1. Compressive strength

Table 7.1 presents opening time of the selected high early-age strength concretes. It can be seen that Rapid Set cement concretes reached their opening time significantly faster than Type III and Type V cement concretes. While they reached opening times within an hour, the opening time of Type III and V cement concretes ranged from 5 to 8.5 hrs. The opening times of Type III cement concretes were slightly shorter than those of Type V cement concretes. The opening time of Type III cement concretes were 0.5 and 1.5 hrs lower than those of Type V cement concretes contained 2.8 and 2% accelerator, respectively. The opening time of 50/50 blended cement concrete was close to the opening time of Rapid Set cement concretes, whereas the opening time of 75/25 blended cement concrete was close to that of Type V cement concrete. While the opening time of 50/50 blended cement concretes was averagely 0.25 hr (15 minutes) more than that of Rapid Set cement concretes, the opening time of 75/25 blended cement concretes was averagely 5 hrs more than that of Rapid Set cement concretes.

The 24-hr and 28-day compressive strength of the selected high early-age strength concretes are shown in Figures 7.1 and 7.2, respectively. It can be seen that at both ages, type V cement concretes contained 2.8% accelerator produced the highest compressive strength. At 24 hrs, the order of compressive strength from the highest to the lowest were Type V-2.8% accelerator, Rapid Set cement, Type III-2% accelerator, Type V-2% accelerator, 50/50 blended cement, and 75/25 blended cement. As Rapid Set cement concrete developed majority of its strength within the first day (almost 84%), they had the lowest 28-day compressive strengths. At this age, the order, from the highest to the

lowest, was Type V-2.8% accelerator, Type III-2% and Type V-2% accelerator, 75/25 blended cement, 50/50 blended cement, and Rapid Set cement.

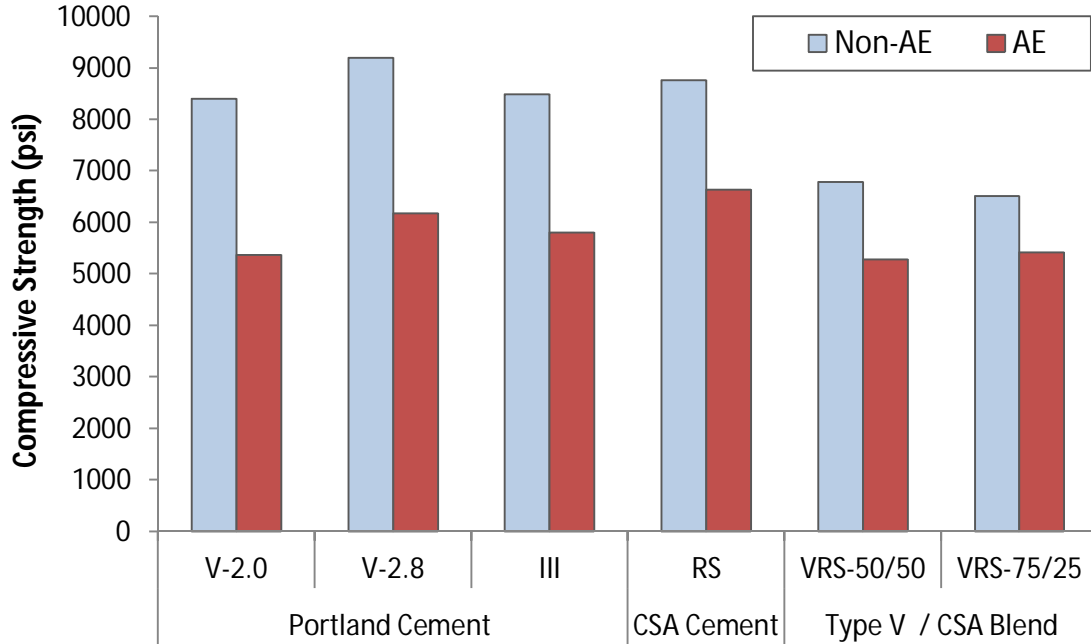

Figure 7-1: Compressive Strength of the Selected HES Concretes at 24 hrs

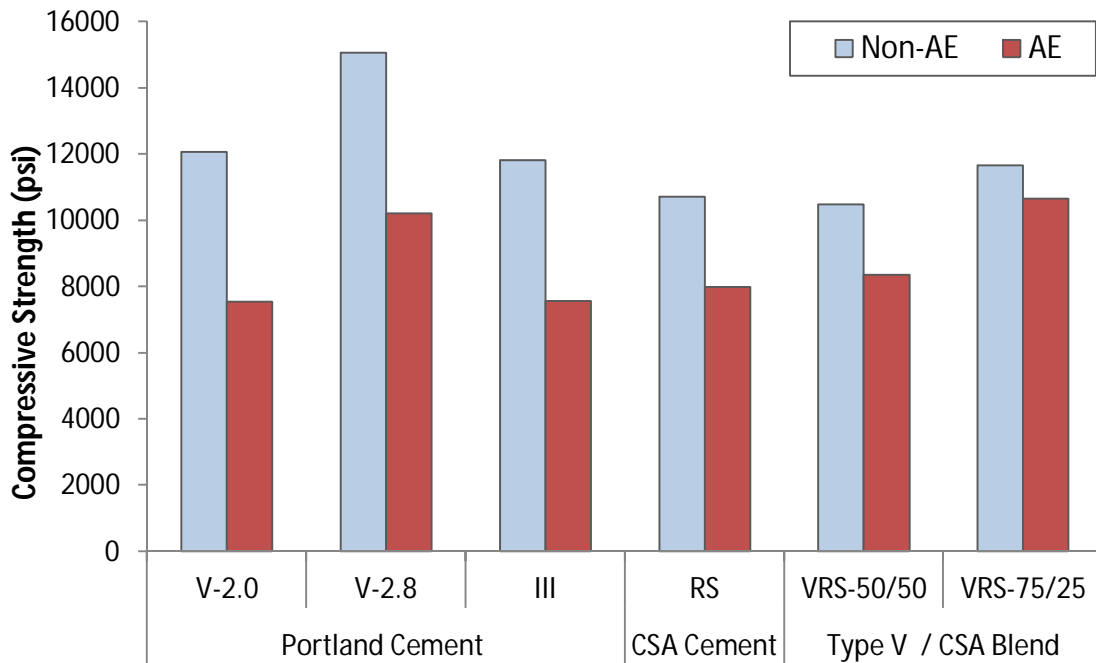

Figure 7-2: Compressive Strength of the Selected HES Concretes at 28 Days

7.2.2. Flexural strength

Figure 7.3 shows results of flexural strength for the selected high early-age strength concretes at different curing ages including opening time, 24 hrs and 28 days. It can be seen that similar to the compressive strength test, Rapid Set cement concretes developed its strength quickly, thus producing the highest flexural strengths at opening time and 24 hrs. As their strength development considerably diminished after 24 hrs, they produced the lowest 28-day flexural strength. The orders of 28-day flexural strengths were as follows:

Opening time: *Rapid Set > Type V-2.0 > 75/25 Blended > Type V-2.8 > Type III > 50/50 Blended*

24 hours: *Rapid Set, Type V-2.0 and Type V-2.8 > Type III > 75/25 Blended > > 50/50 Blended*

28 days: *Type V-2.8 > Type V-2.0, 50/50 Blended and 75/25 Blended > Type III > Rapid Set*

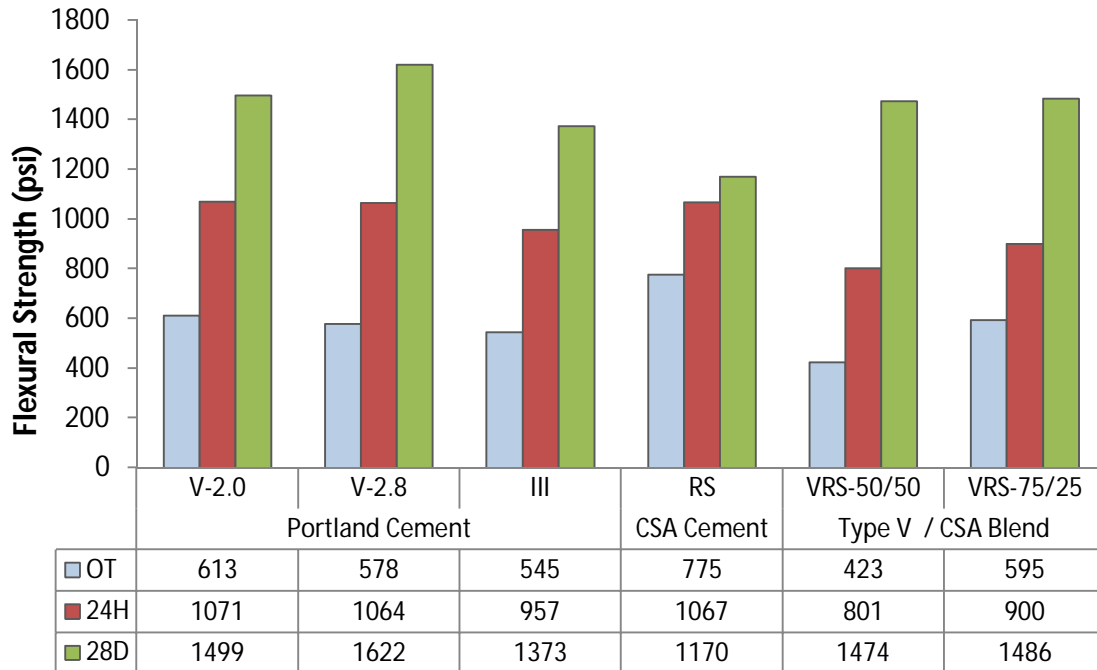

Figure 7-3: Flexural Strength of the Selected HES Concretes

7.2.3. Absorption and Volume of Permeable Voids

Table 7.2 presents results of absorption test for the selected high early-age strength concretes at different curing ages of opening time, 24 hrs and 28 days. The void contents of these concretes are also shown in Figure 7.4.

It can be seen that Rapid Set cement concretes had the highest absorption and void contents within all the studied types of high early-age strength concretes. The absorption and void contents of Rapid Set cement concretes were 1.5 to 3.6 times (with an average of 2.1 times) and 1.3 to 2.8 times (with an average of 1.8 times) of absorption and void contents of Type V cement concretes, respectively. Additionally, their absorption and void contents were averagely 1.6 and 1.5 times of those of Type III cement concretes, respectively. It can also be seen that Type III cement concretes had higher void contents, with an average of nearly 24%, than Type V cement concretes. The blended cement concretes had absorption and void contents between Type V and Rapid Set cement concretes. The higher was the portion of Rapid Set cement in blended cement concretes, the higher was their absorption and void contents.

Table 7-2: Results of Absorption Test for the Selected HES Concretes

Property	Mixture Identification	Testing Time				
		Opening Time	24 hrs	28 days		
Absorption After Immersion (%)	Portland Cement	V-2.0	2.61	1.95	1.05	
		AE-V-2.0	3.35	3.08	1.77	
		V-2.8	3.18	2.33	1.32	
		AE-V-2.8	3.51	3.02	1.45	
		III	3.83	3.69	1.5	
	CSA Cement	AE-III	4.21	3.78	1.99	
		RS	4.83	4.39	3.77	
		AE-RS	5.16	4.85	4.08	
		Type V PC / CSA Blend	VRS-50/50	3.98	3.17	3.02
			AE-VRS-50/50	3.33	2.92	2.82
	VRS-75/25		3.31	3.25	2.42	
	AE-VRS-75/25		2.66	2.68	1.69	
	Void Contents (%)	Portland Cement	V-2.0	7.27	6.29	3.31
			AE-V-2.0	8.61	7.98	4.63
			V-2.8	8.61	6.9	3.75
AE-V-2.8			8.96	8.03	3.78	
III			9.95	9.37	4.16	
CSA Cement		AE-III	10.28	9.62	5.08	
		RS	10.96	10.62	9.33	
		AE-RS	12.46	11.77	9.82	
		Type V PC / CSA Blend	VRS-50/50	10.19	8.42	7.77
			AE-VRS-50/50	8.87	8.66	7.3
VRS-75/25			8.72	8.44	6.34	
AE-VRS-75/25			7.36	7.34	4.82	

* AE: Air-entrained

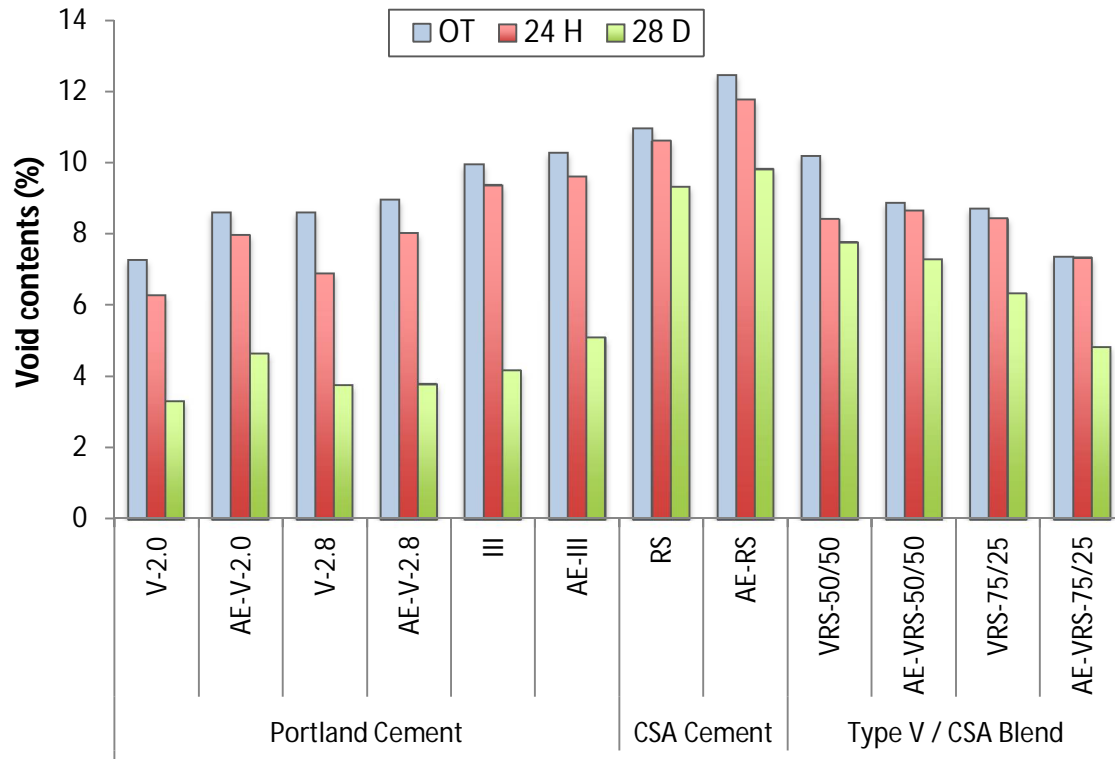

Figure 7-4: Void Contents of the Selected HES Concretes

7.2.4. Rapid Chloride Penetration Test

Figure 7.5 shows results of rapid chloride penetration test (RCPT) for the selected high early-age strength concretes. It can be seen that Rapid Set cement concretes had the lowest charges passed. Their passing charges were averagely 46 and 52% lower than those of Type V and Type III cement concretes, respectively. Type V cement concretes had slightly lower RCPT values than Type III cement concretes. Both blended cement concretes had lower RCPT values than Type V and Type III cement concretes. Overall, the order of the selected concretes in this test, from the best performed to the worst performed, was as follows:

Rapid Set > 75/25 Blended > 50/50 Blended > Type V-2.0 > Type V-2.8 and Type III

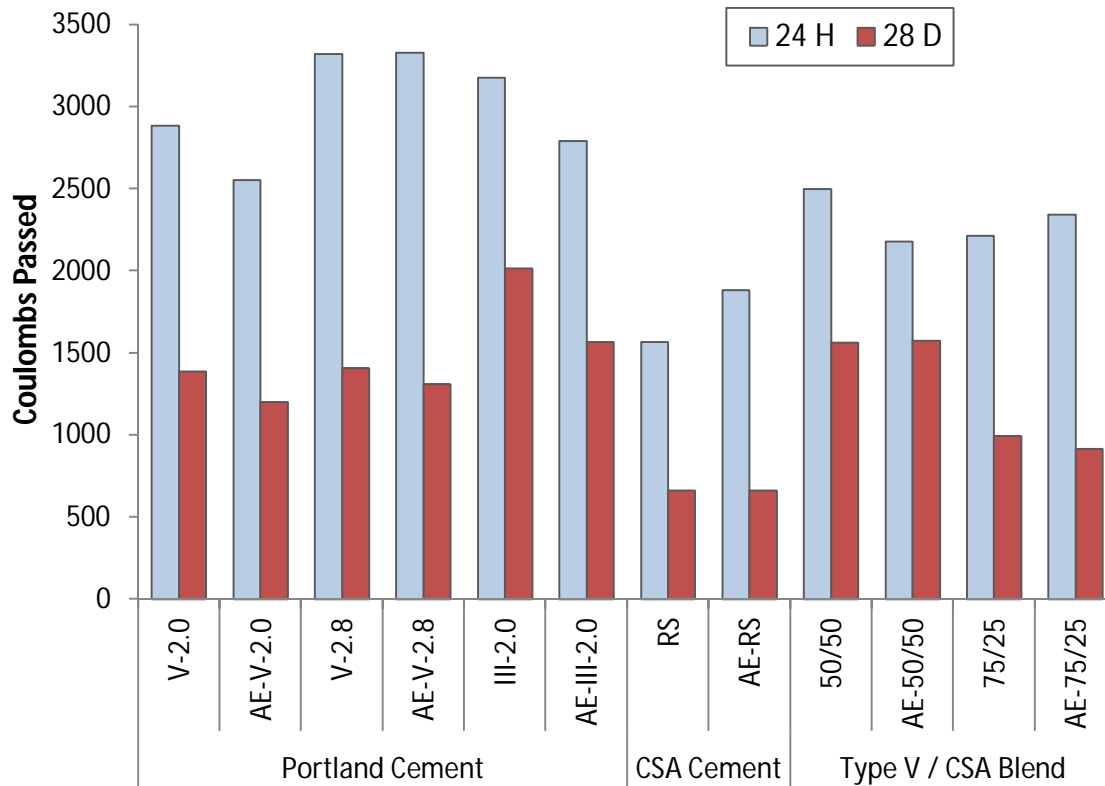

Figure 7-5: Passing Charges of the Selected HES Concretes

7.2.5. Rapid Chloride Migration Test

Figure 7.6 presents results of rapid chloride migration test (RMT) for the selected high early-age strength concretes. Since it wasn't possible to report results of this test for Rapid Set cement concretes, this section only compares results of RMT for the remaining types of high early-age cement concretes.

It can be seen that at both ages of testing, blended cement concretes had the lowest chloride penetration depths. At the age of 24-hr, 75/25 blended cement concrete had averagely 20.1 and 34.7% lower penetration depths than Type III and Type V concretes, respectively. At the ages of 28 days, this blended concrete had 36.7 and 45.3% lower penetration depths than Type III and Type V concretes, respectively. The 50/50

blended cement concrete had almost similar chloride penetration depth to the other types of the studied concretes. It was also observed that chloride penetrated deeper in Type V cement concretes than Type III cement concrete at the age of 24 hrs, whereas an opposite trend was seen for 28-day cured concretes. This can be related to the higher reactivity of Type III cement at early ages in comparison with Type V cement due to its high Blain. Overall, the order of the selected high early-age strength concretes in rapid chloride migration test, from the best performed to the worst performed, was as follows:

24 hours: 75/25 Blended > Type III > Type V-2.0 > Type V-2.8

28 days: 75/25 Blended > 50/50 Blended, Type V-2.0 and Type V-2.8 > Type III

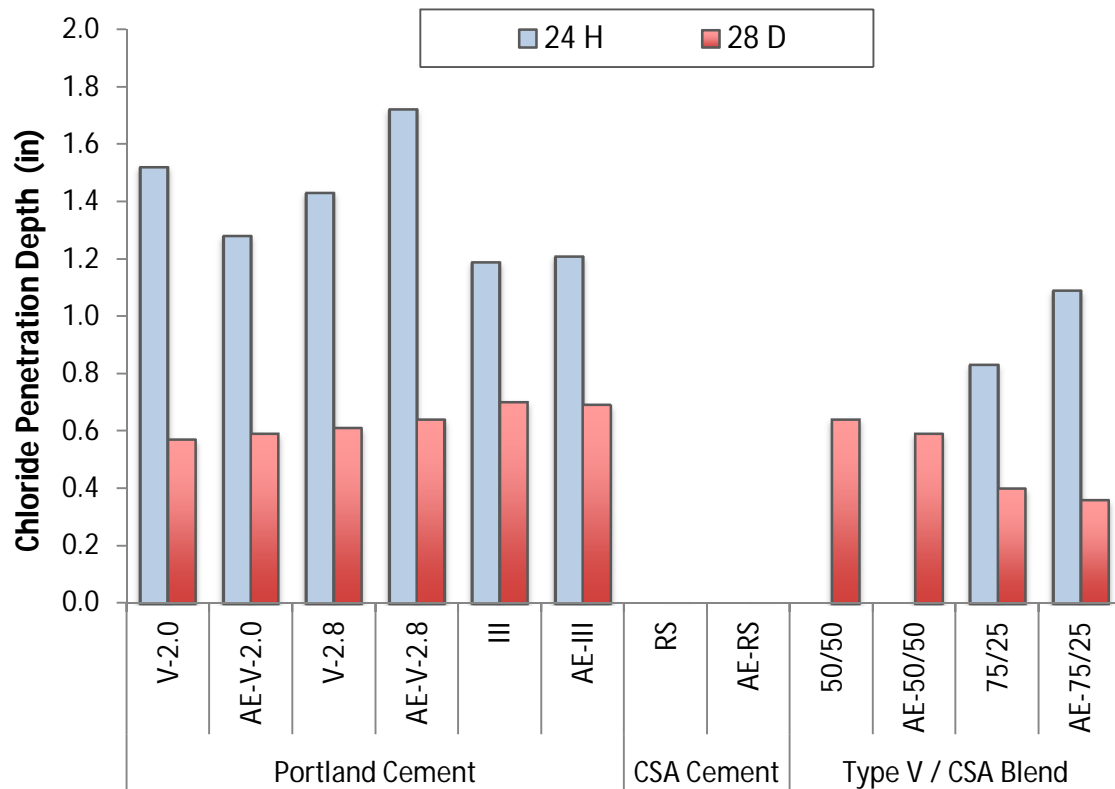

Figure 7-6: Chloride Penetration Depth of the Selected HES Concretes

7.2.6. Water Permeability

Figure 7.7 shows results of water penetration depth for the selected high early-age strength concretes. Two different trends were observed for the concretes tested at 24 hrs and 28 days. While Rapid Set cement concrete performed the worst at the age of 24 hrs, it had the best performance between 28-day cured concretes. At both ages of testing, Type V cement concretes performed better than Type III cement concretes. The performance of blended cement concretes were between the performance of Rapid Set and Type V cement concretes. The water penetration depth of 75/25 blended cement concrete was almost similar to that of Type V concretes.

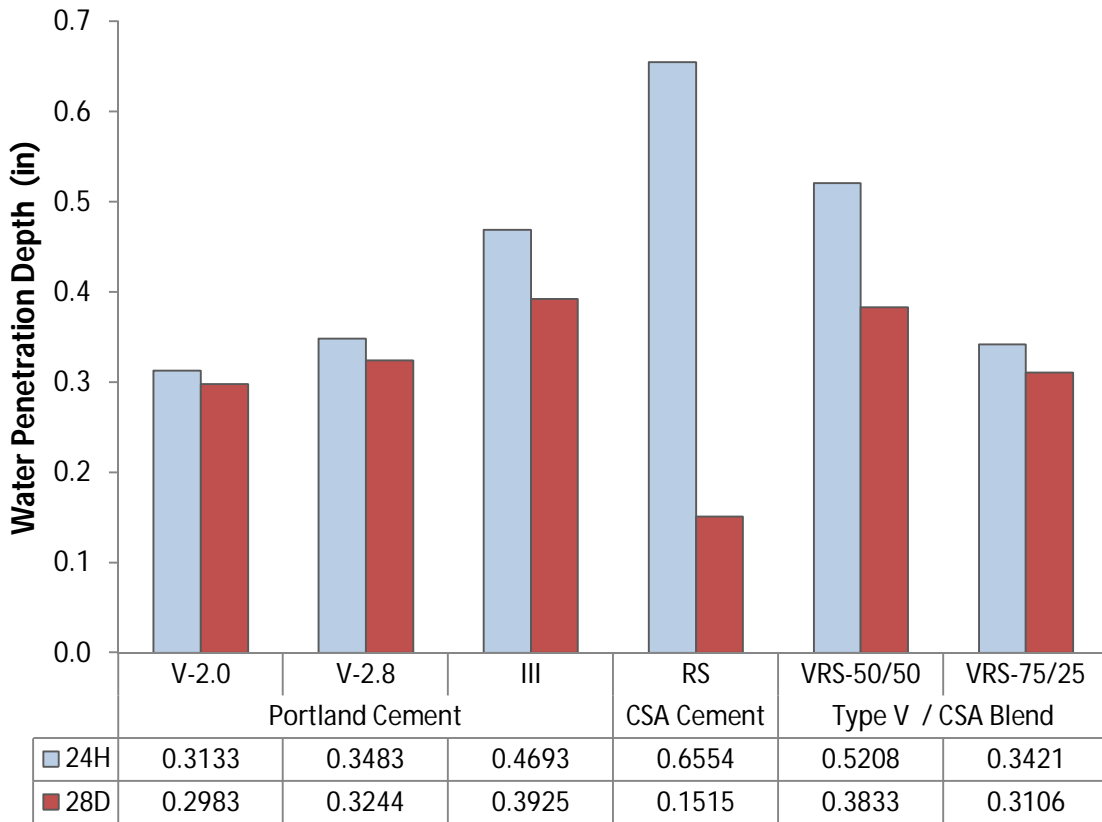

Figure 7-7: Water Penetration Depth of Selected HES Concretes

7.2.7. Drying Shrinkage

Figures 7.8 and 7.9 show drying shrinkage of the selected high early-age strength concretes after 28 days and 6 months storing in the shrinkage room, respectively. Examining the results of Figure 7.8, it can be concluded that the drying shrinkage of all the studied high early-age strength concretes were well below the NDOT specification limit of 0.06%.

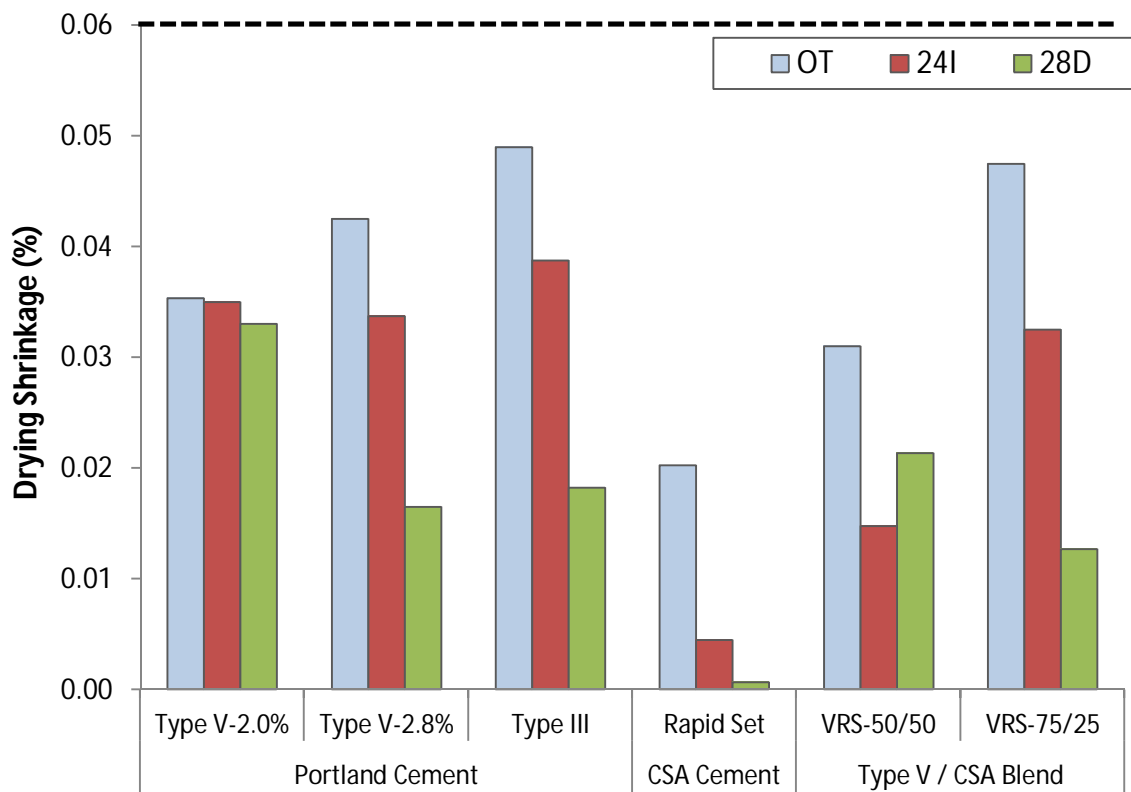

Figure 7-8: Drying Shrinkage of HES Concretes After 28 Days in Shrinkage Room

It can also be seen in these figures that Rapid Set cement concretes had the lowest drying shrinkages amongst all the studied concretes. Their 6-month drying shrinkages were averagely 66 and 72% lower than those of Type V and Type III cement concretes, respectively. It can also be seen that Type V cement concretes shrank less than Type III

cement concretes. The drying shrinkage of blended cement concretes was overall closer to Type V cement concretes than Rapid Set cement concrete.

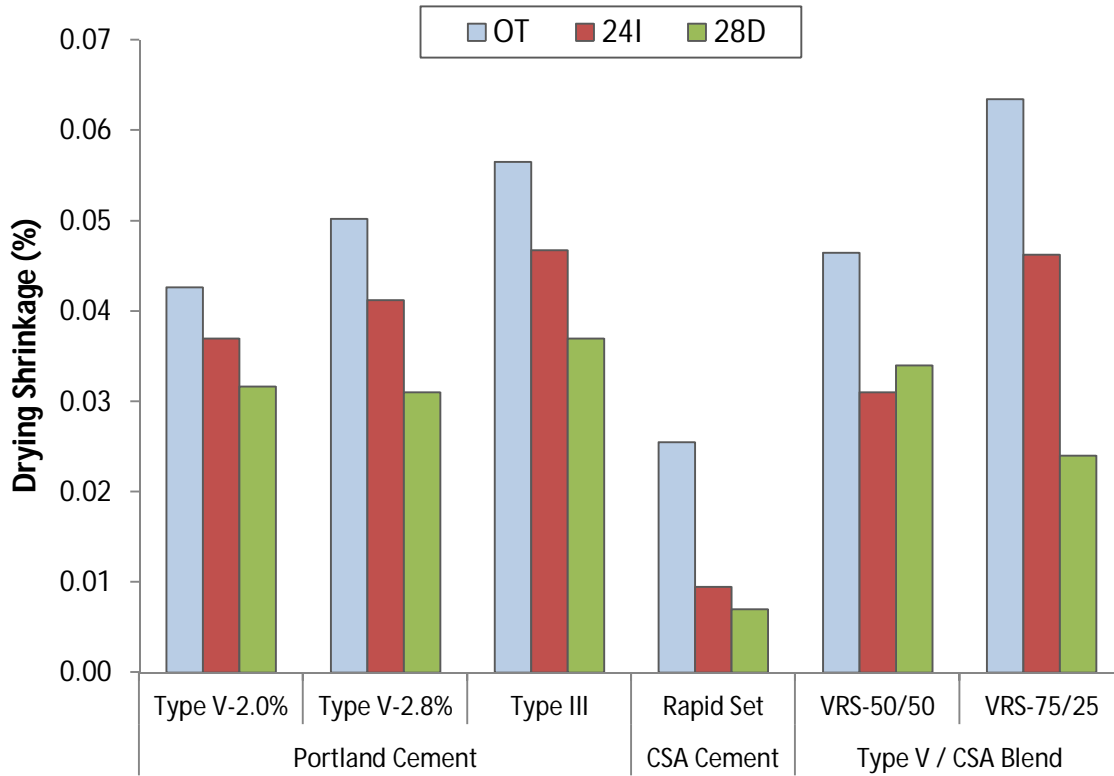

Figure 7-9: Drying Shrinkage of HES Concretes After 7.5 Months in Shrinkage Room

7.2.8. Corrosion Resistance

Figure 7.10 presents failure time of the selected high early-age strength concretes in corrosion test. It can be seen that Rapid Set cement concretes had the weakest performance in corrosion test with the shortest failure times. The failure times of 24-hr Rapid Set cement concretes were 35 and 47% shorter than Type III and Type V cement concretes, respectively. For the concretes tested at the age of 28 days, Rapid Set cement concrete failed 65 and 80% faster than Type III and Type V cement concretes,

respectively. From these results, it can also be concluded that Type V cement concretes were slightly more resistant to corrosion than Type III cement concretes. The blended cement concretes showed two different behaviors for the curing ages of 24 hrs and 28 days. While the 24-hr blended cement concretes performed weak, the 28-day cured blended cement concretes had the highest corrosion resistances.

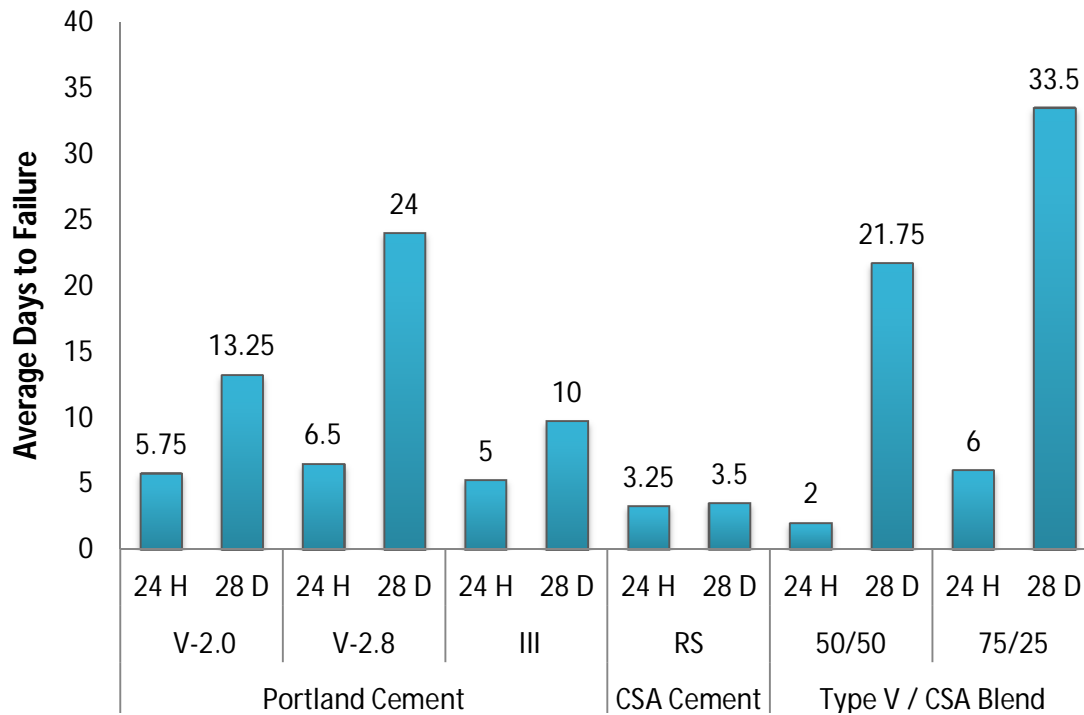

Figure 7-10: Failure Time of HES Concretes in Corrosion Test

7.2.9. Frost Resistance

The frost resistance (ultimate mass loss after 25 freezing and thawing cycles with deicing salt) of the selected high early-age strength concretes is shown in Table 7.3 and Figure 7.11. It can be seen that Rapid Set cement concretes performed considerably weak in frost resistance test. While mass losses of Rapid Set cement concretes were in the

range of 22 to 32%, mass losses of other types of high early-age strength concretes were in the ranges of 1.7 to 5.0%. The mass losses of Rapid Set cement concretes were 5.9, 6.9, 9.0, 9.6 and 12.3 times of those of Type V-2.8% accelerator, Type III-2.0% accelerator, 75/25 blended cement, Type V-2.0% accelerator and 50/50 blended cement concretes, respectively. The frost resistance order, from the most resistant to the least resistant, was as follows:

50/50 Blended > 75/25 Blended and Type V-2.0 > Type III > Type V-2.8 > Rapid Set

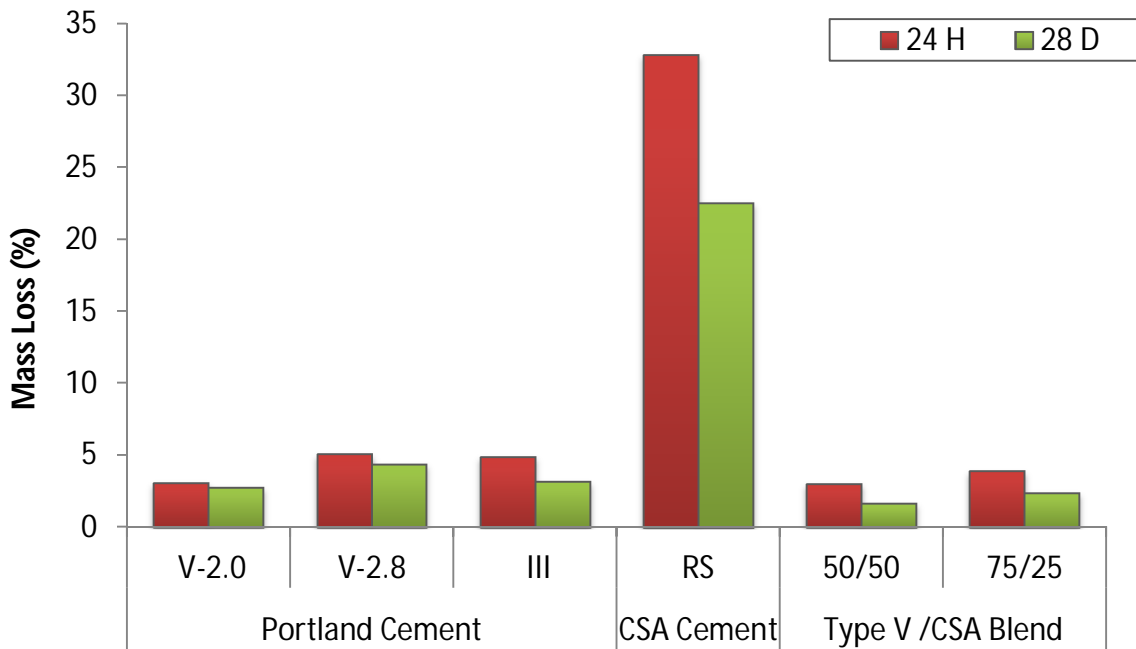

Figure 7-11: Ultimate Mass Loss of the Selected HES Concretes Subjected to 25 Freezing and Thawing Cycles

Table 7-3: Ultimate Mass Loss of the Selected HES Concretes Subjected to 25 Freezing and Thawing Cycles

Curing Age	Portland Cement			CSA Cement	Type V / CSA Blend	
	V-2.0	V-2.8	III	RS	50/50	75/25
24 hrs	3.028	5.023	4.869	32.814	2.9959	3.8722
28 days	2.725	4.335	3.156	22.522	1.6552	2.3628

7.2.10. Abrasion

Table 7.12 presents results of abrasion test for the selected high early-age strength concretes. It can be seen that while overall performance of Type III, Type V and Rapid Set cement concretes were close in this test, the blended cement concretes showed the worst performances. The abrasion resistance order of high early-age strength concretes was as follows:

24 hrs: Type III > Type V-2.0 and Type V-2.8 > Rapid Set > 75/25 Blended > 50/50

Blended

28 days: Rapid Set > Type V-2.8 > Type III > 75/25 Blended > Type V-2.0 > 50/50 Blended

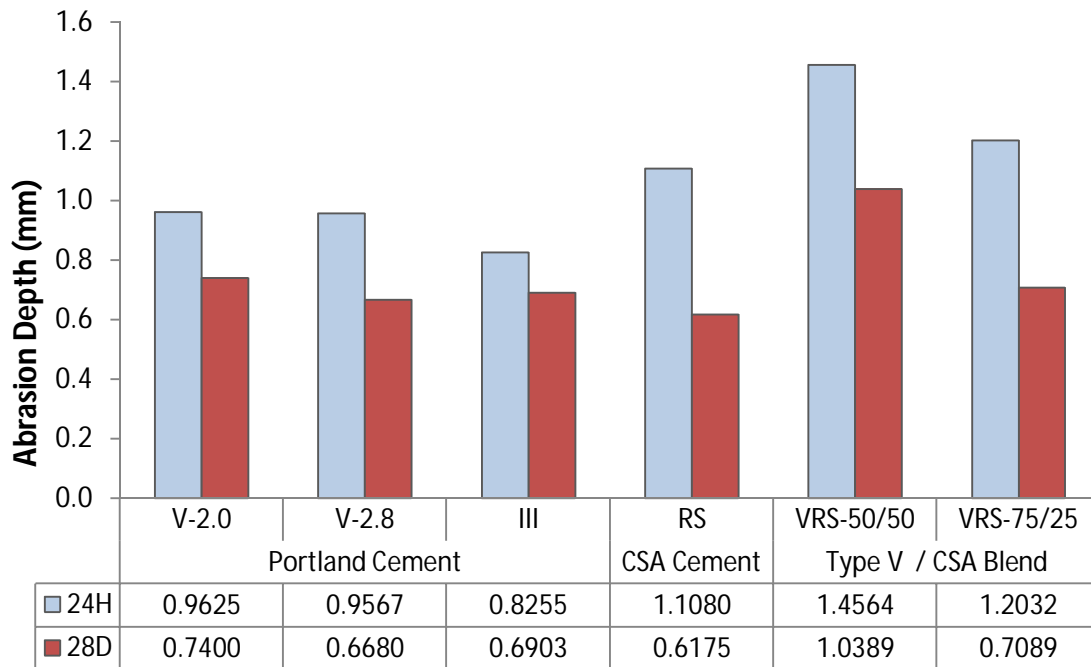

Figure 7-12: Abrasion Depth of the Selected HES Concretes

7.3. Concluding Remarks

Table 7.4 shows ranking (in ascending order of 1 through 6 with 1 meaning "best" and 6 representing "worse" performing mixtures) of the selected high early-age strength concretes for different properties.

It can be seen that overall it's not possible to categorize one type of concrete as the best type of high early-age strength high-performance concrete. In view of opening time, drying shrinkage, RCPT and water permeability; Rapid Set cement concretes had the best results. However, its performance in frost resistance and corrosion tests was really weak. Additionally, it wasn't the best concrete in abrasion and absorption tests. Type V cement concretes had the longest opening times. Their performance in other tests were reasonable and usually amongst the first 3 options. Type III cement concretes had reasonable opening times, but they were not amongst the best performed concretes in drying shrinkage, transport properties, corrosion and frost resistance. The blended cement concretes didn't have the best abrasion resistance and the performance of their 24-hr cured samples was weak in corrosion test. Altogether, selection of the most suitable high early-age high-performance concrete for rapid repair is contingent upon an optimum combination of properties to meet specific design requirements.

Table 7-4: Ranking of the Selected HES Concretes for Different Properties

Properties	Test	Testing Age	Portland Cement			CSA Cement	Type V/ CSA Blend	
			V-2.0	V-2.8	III	RS	50/50	75/25
Opening Time	Compressive Strength	--	6	5	3	1	2	4
Mechanical	Compressive Strength	24 hrs	4	1	3	1	5	5
		28 days	2	1	2	5	5	2
	Flexural Strength	24 hrs	1	1	4	1	6	5
		28 days	2	1	5	6	2	2
Volume Stability	Dry Shrinkage	Opening time	2	4	5	1	3	6
		24 hrs	3	4	5	1	2	5
		28 days	3	3	6	1	5	2
Transport	Absorption and Void Contents	Opening time, 24 hrs & 28 days	1	2	4	6	4	3
	Water Permeability	24 hrs	1	2	4	6	5	2
		28 days	2	2	5	1	5	2
	RCPT	24 hrs & 28 days	4	5	5	1	3	2
	RMT	24 hrs	3	4	2	NA	NA	1
28 days		2	2	5	NA	2	1	
Durability	Corrosion of Steel	24 hrs	2	1	4	5	6	2
		28 days	4	2	5	6	3	1
	Abrasion Resistance	24 hrs	2	2	1	4	6	5
		28 days	5	2	3	1	6	4
	Frost Resistance	24 hrs	1	5	4	6	1	3
		28 days	3	5	4	6	1	2

NA: Not applicable

References

- ASCE (2013). ASCE Report Card, American Society of Civil Engineers, Reston, VA.
- ASCE (2009). ASCE Report Card, American Society of Civil Engineers, Reston, VA.
- ASCE (2005). ASCE Report Card, American Society of Civil Engineers, Reston, VA.
- ASCE (2001). ASCE Report Card, American Society of Civil Engineers, Reston, VA.
- ASCE (1998). ASCE Report Card, American Society of Civil Engineers, Reston, VA.
- American Concrete Pavement Association (ACPA), (Not Dated). Concrete Paving Technology: Fast-Track Concrete Pavements.
- American Society for Testing and Materials (ASTM). (2014). "Standard Test Method for Sieve Analysis of Fine and Coarse Aggregates." C 136, West Conshohocken, Pa.
- American Society for Testing and Materials (ASTM). (2013). "Standard Specification for Concrete Aggregates." C 33, West Conshohocken, Pa.
- American Society for Testing and Materials (ASTM). (2015). "Standard Test Method for Density, Relative Density (Specific Gravity), and Absorption of Fine Aggregate." C 128, West Conshohocken, Pa
- American Society for Testing and Materials (ASTM). (2015). "Standard Test Method for Slump of Hydraulic-Cement Concrete." C 143, West Conshohocken, Pa
- American Society for Testing and Materials (ASTM). (2008). "Standard Test Method for Time of Setting of Concrete Mixtures by Penetration Resistance." C 1403, West Conshohocken, Pa
- American Society for Testing and Materials (ASTM). (2014). "Standard Test Method for Air Content of Freshly Mixed Concrete by the Pressure Method." C 231, West Conshohocken, Pa
- American Society for Testing and Materials (ASTM). (2015). "Standard Test Method for Heat of Hydration of Hydraulic Cement." C 186, West Conshohocken, Pa
- American Society for Testing and Materials (ASTM). (2012). "Standard Test Method for Compressive Strength of Cylindrical Concrete Specimens." C 39, West Conshohocken, Pa.
- American Society for Testing and Materials (ASTM). (2016). "Standard Test Method for Flexural Strength of Concrete (Using Simple Beam with Third-Point Loading)." C 78, West Conshohocken, Pa

American Society for Testing and Materials (ASTM). (2008). "Standard Test Method for Length Change of Hardened Hydraulic-Cement Mortar and Concrete." C 157, West Conshohocken, Pa

American Society for Testing and Materials (ASTM). (2013). "Standard Test for Density, Absorption, and Voids in Hardened Concrete." C 642, West Conshohocken, Pa.

American Society for Testing and Materials (ASTM). (2012). "Standard Test Method for Electrical Indication of Concrete's Ability to Resist Chloride Ion Penetration." C 1202-12, West Conshohocken, Pa.

American Society for Testing and Materials (ASTM). (2012). "Standard Test Method for Abrasion Resistance of Horizontal Concrete Surfaces." C 779, West Conshohocken, Pa

American Society for Testing and Materials (ASTM). (2012). "Standard Test Method for Scaling Resistance of Concrete Surfaces Exposed to Deicing Chemicals." C 672, West Conshohocken, Pa

Ansari, F., Luke, A., Vitillo, N. P., Blank, N., Turhan, I. (1997, May). Developing Fast Track Concrete for Pavement Repair. *Concrete International*. pp. 24-29

Bescher, E. P.,(2014). Calcium Sulfoaluminate-Belite Concrete: Structure, Properties, Practice. PowerPoint presentation.
<http://www.cptechcenter.org/ncc/Sp2015%20NCC/03%20Wed%20Bescher-Calcium%20Sulfoaluminate-Belite%20Concrete.pdf> (Retrieved January 2017)

Buch, N., Van Dam, T. J., Peterson, K., Sutter, L. (2006 – online). Evaluation of High-Early Strength PCC Mixtures Used in Full Depth Repairs. *Construction and Building Materials*. Vol. 22, pp. 162-174. Science Direct (2008).

European Committee for Standardization (CEN). (2000). "Testing hardened concrete – Part 8: Depth of penetration of water under pressure." EN 12390-8:2000, Brussels.

Florida Department of Transportation (FDOT), (2000). "Florida Method of Test for an Accelerated Laboratory Method for Corrosion Testing of Reinforced Concrete Using Impressed Current." FM 5-522, Florida.

Ghafoori, N., Diawara, H., Beasley, S. (2008) Resistance to External Sodium Sulfate Attack for Early-Opening-to-Traffic Portland Cement Concrete. *Cement and Concrete Composites*. Vol. 30, pp. 444-454. Science Direct

Grove, J. D., Jones, K. B., Bharil, K. S., Calderwood, W. (1989). Fast Track and Fast Track II. *Transportation Research Record 1282*. Transportation Research Board. National Research Council. Washington, DC. pp. 1-7

Hall, M. J., (1993). Wisconsin Fast-Track Paving Experiences. *Proceedings of the 4th Materials Engineering Conference on Materials for the New Millennium*. Vol.1 (pp. 456-465) New York, NY: American Society of Civil Engineers.

- Jones, K. B. (1988, June). Special Cements for Fast Track Concrete. *Final Report MLR-87-4*. Iowa Department of Transportation – Highway Division.
- Knutson, M., Riley, R. (1987, January). Fast-Track Concrete Paving Opens the Door to Industry Future. *Concrete Construction*. pp. 19-22
- Kosmatka, S. H., Kerkhoff, B., Panarese, C. (1994). *The Design and Control of Concrete Mixtures* (14th ed.), Skokie, Illinois: Portland Cement Association
- Kumar, M. K., Rao, P. S., Swamy, (2012). High Early Strength Concrete without Steam Curing. *International Journal of Engineering and Innovative Technology*. Vol. 2, No. 1, pp. 228-233. (ISSN: 2277-3754)
- Mehta, P. K., Monteiro, P. J. M. (1992). *Concrete Structures, Properties, and Materials*, 2nd Ed.
- Min, T. B., Cho, I. S., Park, W. J., Choi, H. K., Lee, H. S. (2014). Experimental Study on the Development of Compressive Strength of Early Concrete Age Using Calcium-Based Hardening Accelerator and High Early Strength Cement. *Construction and Building Materials*. Vol. 64, pp. 208-214. Science Direct.
- Mindess, S., Young, J. F., & Darwin, D. (2003). *Concrete* (2nd ed.). Upper Saddle River, New Jersey: Prentice Hall.
- Nordtest. (1999). “Chloride Migration Coefficient from Non-Steady-State Migration Experiments.” NT Build 492, Espoo, Finland.
- Ohio Department of Transportation (ODOT), (2007, May). High Early Strength Concrete Overlays. *Departmental Report*. Ohio Department of Transportation: Office of Materials Management, Cement and Concrete Section.
- Ozyildirim, C. (1993, January). High-Performance Concrete for Transportation Structures. *Concrete International*. pp. 33-38
- Pearson, R. I. (1988, August) Fast Track Paving, *Concrete International*. pp. 33-35
- Pera, J., Ambroise, J. (2004). New Applications of Calcium Sulfoaluminate Cement. *Cement and Concrete Research*. Vol. 34, pp. 671-676. Science Direct.
- Soutsos, M. N., Barnett, S. J., Bungey, J. H., Millard, S. G. (Not Dated). Fast Track Construction with High-Strength Concrete Mixes Containing Ground Granulated Furnace Slag. *Report Number SP-228-19*.
- Sprinkel, M. M., (1988, September). High Early Strength Latex Modified Concrete. *Concrete Construction*. pp. 831-836
- Tays, M. W. (2002). Matthew Tays “Abrasion Resistance of Fast-Track Portland Cement Concrete” master’s thesis, Tennessee Technological University, 2002.

Todd, N. T. (2015). Todd Nathan, “Assessing Risk Reduction of High Early Strength Concrete Mixtures” master’s thesis, Purdue University, 2015, ProQuest (10062227)

Wenzlick, J. D.(2006). Evaluation of Very High Early Strength Latex Modified Concrete Overlays. *Organizational Results Research Report RI04-005*. Missouri Department of Transportation.

Whiting, D., Nagi, M., Okamoto, P. A. (1994, December). Early Strength Gain of Rapid Highway Repair Concrete. *Concrete International*. pp. 28-35

Zhu, P., Zhongguo, J. M.(2010, November). Selection of Durable Closure Pour Materials for Accelerated Bridge Construction. *ASCE Journal of Bridge Engineering*. Vol. 15, No. 6, pp. 695-704. (ISSN: 1084-0702)

www.cbpp.org/research/state-budget-and-tax/its-time-for-states-to-invest-in-infrastructure (retrieved 5/22/16)

www.mapofusa.net/usa-map.jpg (retrieved 5/12/16)

www.RapidSet.com

Appendix A

Survey Results

Appendix A presents the received responses to the national survey that was sent out to all U.S. State Departments of Transportation, and Federal Highway Authority regional offices. Below is a list agencies that responded along with their agency initials that are used in the tables.

MADOT	Massachusetts Department of Transportation
KYDOT	Kentucky Department of Transportation
NEDOT	Nebraska Department of Transportation
FLDOT	Florida Department of Transportation
ALDOT	Alabama Department of Transportation
ARDOT	Arkansas Department of Transportation
INDOT	Indiana Department of Transportation
CADOT	California Department of Transportation
KSDOT	Kansas Department of Transportation
LADOT	Louisiana Department of Transportation
CTDOT	Connecticut Department of Transportation
ILDOT	Illinois Department of Transportation
IADOT	Iowa Department of Transportation
HIDOT	Hawaii Department of Transportation
VADOT	Virginia Department of Transportation
AZDOT	Arizona Department of Transportation
IDDOT	Idaho Department of Transportation
VTDOT	Vermont Department of Transportation

Table A- 1: Survey Responses for Massachusetts, Kentucky, Nebraska, and Florida

Question	MADOT	KYDOT	NEDOR	FLDOT
1 Does your DOT agency currently use HES Concrete in pavement and bridge deck repairs?	Yes	Yes	Yes	Yes
2 What are the minimum and maximum opening times your agency uses for HES repairs?	36hr	24hr, 48hr, 72 hr	24hr for PR-1 & PR-3, 48hr for 47B-HE	OT @ req. C.S., 24hr
3 What is the minimum required opening time compressive strength?	3500 psi	3000 psi	3000 psi	OT-2000 psi; 24hr-3000 psi (July 2016-1600 psi by maturity meter; 3000 psi @ 28 day)
4 What is the minimum required opening time flexural strength?		N/A	No Spec.	Not req'd
5 What is the maximum allowed drying shrinkage at 28 days?		N/A	No Spec.	Not req'd
6 What type(s) of Portland cement is typically used by your agency?		Type I/II, Type III	PR-1: Type I/II; PR-3: Type III; 47B-HE: Type IP & IT interground / blended cement	I, II, III & blended cements; HES typically Type II
7 What is the most common weight of cement per cubic yard for pavement and bridge deck repairs? (lb/yd3)		24hr-799lb/yd3; 48hr-729lb/yd3; 72h -658lb/yd3 (If Type III a reduction of 94lbs)	PR-1: 752 lbs; PR-3: 799 lbs; 47B-HE: 752 lbs	650-900 lb/yd3
8 Do you use Rapidset cement? If yes, what is the minimum amount per cubic yard?	Yes	min. - 658lb/yd3	?	No
9 Does your agency allow the use of alternate cementitious materials? Pozzalons : Type & Minimum percentage allowed. Slag : Minimum percentage allowed. Silica Fume : Minimum percentage allowed. Other:		Yes F&C, Max20&30% Max30% Max10%	Yes F, Min 25% Min 20-40%	Yes F, Min 18-22% 50%

Table A- 2: Survey Responses for Massachusetts, Kentucky, Nebraska, and Florida

Question	MADOT	KYDOT	NEDOR	FLDOT
10 What is the minimum and maximum water/cement ratio used?		Max w/c : 24hr-0.33, 48hr-0.34, 72hr-0.35	PR-1: Max 0.3; PR-3: Max 0.45; 47B-HE: Max 0.40	No Spec.
11 What are the curing type(s) your agency uses?		curing compound, wet burlap, or curing blankets	PR-Poly sheeting and insulating boards; HE-White pigment or wet burlap	HES-curing compound & 2 insulating / curing blankets until OT
12 If your agency uses curing blankets, what is the typical R-Value?		N/A	Min. R-5	R-2.5
13 Does your agency allow for the use of accelerating admixers in pavement and bridge deck repairs?		Yes	Yes	Pavement-yes; Bridge-No
If yes, what types and what are the minimum and maximum percentage allowed?		Type C & Type E included on List of Approved Materials, dosage per manufacturer	For pavement: Calcium chloride; For Bridges: non-chloride based	Chloride based Type C and E, dosage per manufacturer
14 Does your agency allow the use of retarding admixers in pavement and bridge deck repairs?		Yes		Yes
If yes, what types and what are the minimum and maximum percentage allowed?		Type D & Type G included on List of Approved Materials, dosage per manufacturer recommendation.	?	Types A and D, dosage per manufacturer
15 What is the minimum & maximum air content allowed?		6 ± 2%	6.0-8.5%	1-6%

Table A- 3: Survey Responses for Alabama, Arkansas, Indiana, and California

Question	ALDOT	ARDOT	INDOT	CADOT
1 Does your DOT agency currently use HES Concrete in pavement and bridge deck repairs?	Yes	Yes	Yes, pavement	Yes
2 What are the minimum and maximum opening times your agency uses for HES repairs?	Min 6hr; Max grouted slab=12hr; Max replaced slab=24hr	Min 2.5hr; No max spec.	Pavement- designed to flexural strength of 550 psi at 2 days	No Spec.
3 What is the minimum required opening time compressive strength?	2500 psi	1500 psi	N/A	1500 psi-Answers to 3 and 4 are not related. Different applications require different strengths
4 What is the minimum required opening time flexural strength?	None for HES	No Spec.	Pavement-550 psi	400 psi
5 What is the maximum allowed drying shrinkage at 28 days?	Pavements-No spec; Bridge deck=0.040%	0.20% Modified AASHTO T 107-07	No Spec.	0.045 or 0.050 depending application
6 What type(s) of Portland cement is typically used by your agency?	Type I/II, some Type III	Type I	Pavement Type I or III	Normal concrete – Type II; Rapid Strength Concrete – Type III, (although not specified alternate cement is also allowed)
7 What is the most common weight of cement per cubic yard for pavement and bridge deck repairs? (lb/yd3)	700-800 lb/yd3		Pavement 564 lb/yd3	800 lb/yd3
8 Do you use Rapidset cement? If yes, what is the minimum amount per cubic yard?	No	Yes		Yes, 700-750 lb/yd3
9 Does your agency allow the use of alternate cementitious materials? Pozzalons : Type & Minimum percentage allowed. Slag : Minimum percentage allowed. Silica Fume : Minimum percentage allowed. Other:	Yes C&F, No min No min No min	Yes IP; 20% 25% Not allowed		Yes F, Min 15-25% 35-50% up to 12%

Table A- 4: Survey Responses for Alabama, Arkansas, Indiana, and California

Question	ALDOT	ARDOT	INDOT	CADOT
10 What is the minimum and maximum water/cement ratio used?	No min; Max=0.45	To produce 2" slump, Max 0.44	Pavement Max. Type I 0.42, Type III 0.45	No Spec.
11 What are the curing type(s) your agency uses?	Curing compounds, wet burlap for pavement repair; wet burlap or continuous fogging for bridge decks	No spec. for repairs	Pavement-Approved curing compound within 30 min of placement	Water, water proof membrane and curing compound
12 If your agency uses curing blankets, what is the typical R-Value?		No spec. for repairs		R-1 to R-3
13 Does your agency allow for the use of accelerating admixers in pavement and bridge deck repairs?	Yes	Yes	Yes, pavement	Yes
If yes, what types and what are the minimum and maximum percentage allowed?	Non-Chloride based Type C, dosage per manufacturer	No min; Max=1/2 manufacture dosage	Max. fly ash 10%, GGBFS 15%, both of cement content. Type A, B, C, D, E	Any meeting ASTM admixture requirements. Dose not specified
14 Does your agency allow the use of retarding admixers in pavement and bridge deck repairs?	Yes-but not common	Yes	Yes	Yes
If yes, what types and what are the minimum and maximum percentage allowed?	Types A and D, dosage per manufacturer	No min; Max=1/2 manufacture dosage	Type B or Type D, in accordance with AASHTO M 194	Any meeting ASTM admixture requirements. Dose not specified
15 What is the minimum & maximum air content allowed?	2.5-6%	No spec. for repairs	5-8%	For Freeze/Thaw environment typically 6 ± 1.5

Table A- 5: Survey Responses for Kansas, Louisiana, Connecticut, and Illinois

Question	KSDOT	LADOT	CTDOT	ILDOT
1 Does your DOT agency currently use HES Concrete in pavement and bridge deck repairs?	Yes	Yes	Yes	Yes (called PP)
2 What are the minimum and maximum opening times your agency uses for HES repairs?	Pavements Min 4-6 hrs	Nighttime construction- construction times may finish at 6:00am	Designed to compressive strength, Times may be based on previous test results for a specified mix	PP-1: 48 hours, PP-2: 24 hours, PP-3: 16 hours, PP-4: 8 hours, PP-5: 4 hours
3 What is the minimum required opening time compressive strength?	Pavements or intersections 1800 psi	3000 psi	2500 psi	3200 psi for all
4 What is the minimum required opening time flexural strength?	Pavement 380 psi	No Spec.	No Spec.	600 psi for all
5 What is the maximum allowed drying shrinkage at 28 days?	No Spec.	No Spec.	No Spec., CTDOT prequalifies products	No Spec.
6 What type(s) of Portland cement is typically used by your agency?	For HES-Type I, IP(x), IS(x), IT(Ax)(By), II or Type III	Types I, II, or III	HES concrete is made from a proprietary bagged mix	PP-1: I/II or III, PP-2: I/II, PP-3: III, PP-4: I/II, PP-5: I/II
7 What is the most common weight of cement per cubic yard for pavement and bridge deck repairs? (lb/yd3)	600-900 lb/yd3	Usually >700 lb/yd3	Mixed according to the manufacturer, contractor submits mix design	PP-1: 650-750 (I/II) or 620-720 (III), PP-2: 735, PP-3: 735 (III), PP-4: 600-625 (from approved list of rapid hardening cement), PP-5: 675 (calcium aluminate cement)
8 Do you use Rapidset cement? If yes, what is the minimum amount per cubic yard?	Yes-per manufacturer	Yes-Emergency repairs	Yes, contractor decides	No
9 Does your agency allow the use of alternate cementitious materials?	Yes	Yes	No	Yes
Pozzalons : Type & Minimum percentage allowed.	Max 25%	No Spec.		See #7
Slag : Minimum percentage allowed.	Max 40%	No Spec.		PP-3: +100 lb/yd3
Silica Fume : Minimum percentage allowed.	Max 5%	Max 10%		See #7
Other:	Blended SCM Max 25%			PP-3: Microsilica +50 lb/yd3

Table A- 6: Survey Responses for Kansas, Louisiana, Connecticut, and Illinois

Question	KSDOT	LADOT	CTDOT	ILDOT
10 What is the minimum and maximum water/cement ratio used?	No spec. (0.40-0.50 typical)	Typical <0.40; Max 0.53	Contractor decides	PP-1: 0.32-0.44, PP-2: 0.32-0.38, PP-3: 0.32-0.35, PP-4: 0.32-0.50, PP-5: 0.32-0.40
11 What are the curing type(s) your agency uses?	Type 2 Liquid Membrane compounds, Burlap, and Sheet Materials	Contractor decides; curing boxes for test cylinders	No Spec.	Waterproof paper, polyethylene sheeting, wetted burlap, type II curing compound, or wetted cotton mat
12 If your agency uses curing blankets, what is the typical R-Value?	contractor decides	contractor decides	No Spec.	
13 Does your agency allow for the use of accelerating admixers in pavement and bridge deck repairs?	Yes	Yes	No	Yes
If yes, what types and what are the minimum and maximum percentage allowed?	Cacl-Max 2%; Non-Chloride based, dosage per manufacturer	Non-Chloride based		Non-Chloride based, dosage per manufacturer- (Except PP-4 none allowed)
14 Does your agency allow the use of retarding admixers in pavement and bridge deck repairs?	Yes	No	No	Yes
If yes, what types and what are the minimum and maximum percentage allowed?	dosage per manufacturer			Dosage per manufacturer- (Except PP-5 none allowed)
15 What is the minimum & maximum air content allowed?	5-8%	2-7%	Contractor decides	4-6% for all (except PP-1, 1-7%)

Table A- 7: Survey Responses for Iowa, Hawaii, Virginia, and Arizona

Question	IADOT	HIDOT	VADOT	AZDOT
1 Does your DOT agency currently use HES Concrete in pavement and bridge deck repairs?	Yes	Yes	Yes	Yes
2 What are the minimum and maximum opening times your agency uses for HES repairs?	Min 12-28 Depeding on ambient temp.	Min. Typically 3 hr	Min 2 hr	Max 12 hr for PCC, Max 24 hr for Epoxy/Epoxy Urethane
3 What is the minimum required opening time compressive strength?	2500- 4000 psi depending on size and depth of repair	3000 psi. for Bridge Deck	4000 psi	3000 psi for PCC, 5000 psi for Epoxy/Epoxy Urethane
4 What is the minimum required opening time flexural strength?		450 psi, 550 psi @ 7 day (PCCP)		No Spec.
5 What is the maximum allowed drying shrinkage at 28 days?		0.03% Bridge Deck		No Spec.
6 What type(s) of Portland cement is typically used by your agency?	Type I, II, IP, IS	Type I and II for PCCP		Type II-III-IV
7 What is the most common weight of cement per cubic yard for pavement and bridge deck repairs? (lb/yd3)	825 lbs for Type I/II repair	700 to 800 lbs. PCCP. 650 lbs. Bridge deck repairs		490 lbs of Portland cement with an additional 20-25% (by cwt) Type F Fly Ash
8 Do you use Rapidset cement? If yes, what is the minimum amount per cubic yard?	Yes	Yes- No min, Max 760 lb	No	Not specified but allowed
9 Does your agency allow the use of alternate cementious materials? Pozzalons : Type & Minimum percentage allowed. Slag : Minimum percentage allowed. Silica Fume : Minimum percentage allowed. Other:	Yes C, Min: 20% Min 35%, Max 50% N/A	No	Yes	Yes F, Min 20% No Yes

Table A- 8: Survey Responses for Iowa, Hawaii, Virginia, and Arizona

Question	IADOT	HIDOT	VADOT	AZDOT
10 What is the minimum and maximum water/cement ratio used?	0.40 for repair with Type I/II			≤ 4500 psi 0.50 Max, > 4500 psi o.45 Max
11 What are the curing type(s) your agency uses?	Wet burlap	ACI 305 Hot Weather concreting and cements Manufacturer's recommendations (Rapid set for Bridge Deck). Wht Cure compound for PCCP		Liquid Membrane Forming Compound + Water Curing
12 If your agency uses curing blankets, what is the typical R-Value?	Yes-Varies	No Spec		No Spec.
13 Does your agency allow for the use of accelerating admixers in pavement and bridge deck repairs?	Yes	Yes	Yes	Yes
If yes, what types and what are the minimum and maximum percentage allowed?	Varies	Comply with AASHTO M 194 (ASTM C494)- dosage per manufacturer		ASTM C494 Types B & E, dosage per manufacturer
14 Does your agency allow the use of retarding admixers in pavement and bridge deck repairs?	Yes	Yes	Yes	Yes
If yes, what types and what are the minimum and maximum percentage allowed?	Varies	Comply with AASHTO M 194 (ASTM C494)- dosage per manufacturer		ASTM C494 Types C & D, dosage per manufacturer
15 What is the minimum & maximum air content allowed?	5.5-8.5%	3 ± 1% for PCCP, 4-5% for Bridge Deck (RapidSet)		< 3000 ft No Min, ≥ 3000 ft Min 4%, Max 7%

Table A- 9: Survey Responses for Idaho and Vermont

Question	IDDOT	VTDOT
1 Does your DOT agency currently use HES Concrete in pavement and bridge deck repairs?	Yes	Yes
2 What are the minimum and maximum opening times your agency uses for HES repairs?	Max Typically 18-36 hr	OT @ req. C.S. - As low as 4 hrs in the field
3 What is the minimum required opening time compressive strength?	3500 psi	4000 psi
4 What is the minimum required opening time flexural strength?	N/A	
5 What is the maximum allowed drying shrinkage at 28 days?	N/A	Max Allowed = 0.04%
6 What type(s) of Portland cement is typically used by your agency?	Type III	Type II, III
7 What is the most common weight of cement per cubic yard for pavement and bridge deck repairs? (lb/yd ³)	660 lbs	900lbs of cementitious material. Type II ranges from 600 - 670lbs. For Lafarge Tercem 900lbs.
8 Do you use Rapidset cement? If yes, what is the minimum amount per cubic yard?	No	?
9 Does your agency allow the use of alternate cementitious materials?	Yes	Yes
Pozzalons : Type & Minimum percentage allowed.	F, Min 20%	F, Min to mitigate ASR
Slag : Minimum percentage allowed.	Min 20%	Min to mitigate ASR
Silica Fume : Minimum percentage allowed.	Min 7%	Min to mitigate ASR
Other:		

Table A- 10: Survey Responses for Idaho and Vermont

	Question	IDDOT	VTDOT
10	What is the minimum and maximum water/cement ratio used?	Max 0.40	Not Specified - lowest possible
11	What are the curing type(s) your agency uses?	Wet Cure and or Curing Compound	Wet cured until design strength reached
12	If your agency uses curing blankets, what is the typical R-Value?	N/A	Not for repairs
13	Does your agency allow for the use of accelerating admixers in pavement and bridge deck repairs?	Yes	yes, if designed and tested
	If yes, what types and what are the minimum and maximum percentage allowed?	ASTM C494 Non-chloride, dosage per manufacturer	From approved products list, contractor to decide dosage
14	Does your agency allow the use of retarding admixers in pavement and bridge deck repairs?	Yes	yes, if designed and tested
	If yes, what types and what are the minimum and maximum percentage allowed?	ASTM C494, dosage per manufacturer	From approved products list, contractor to decide dosage
15	What is the minimum & maximum air content allowed?	Paving 4.0- 7.0%, Bridge 5.0-8.0%	7 ± 1.5 %