

**NDOT Research Report**

**Report No. 048-15-803**

---

**Development of a Statewide Pilot Project for  
Standardized TIM Performance Measurement  
and Reporting**

---

**July 2016**

**Nevada Department of Transportation  
1263 South Stewart Street  
Carson City, NV 89712**



### **Disclaimer**

This work was sponsored by the Nevada Department of Transportation. The contents of this report reflect the views of the authors, who are responsible for the facts and the accuracy of the data presented herein. The contents do not necessarily reflect the official views or policies of the State of Nevada at the time of publication. This report does not constitute a standard, specification, or regulation.

## TECHNICAL REPORT DOCUMENTATION PAGE

1. Report No. 048-15-803	2. Government Accession No.	3. Recipient's Catalog No.	
4. Title and Subtitle Development of a Statewide Pilot Project for Standardized TIM Performance Measurement and Reporting		5. Report Date July 15, 2016	
		6. Performing Organization Code	
7. Author(s) Kelley Klaver Pecheux, Benjamin Pecheux, Cara O'Donnell – Applied Engineering Management Corporation		8. Performing Organization Report No.	
9. Performing Organization Name and Address Applied Engineering Management Corporation 13880 Dulles Corner Lane Suite 300 Herndon, VA 20171		10. Work Unit No. (TRAIS)	
		11. Contract or Grant No.	
12. Sponsoring Agency Name and Address Nevada Department of Transportation 1263 South Stewart Carson City, NV 98712		13. Type of Report and Period Covered Final Report	
		14. Sponsoring Agency Code NDOT	
15. Supplementary Notes			
16. Abstract This report describes the approach and findings associated with the development of a statewide pilot project for standardized traffic incident management (TIM) performance measurement and reporting. The project included four primary objectives: (1) benchmark Nevada's practices against those of leading peer agencies, (2) assess the quantity and quality of incident data available in Nevada, (3) develop a prototype integrated TIM performance database using available data, and (4) develop a prototype interactive dashboard that displays TIM performance measures using the database. Five sources of incident data were assessed: the Nevada Department of Transportation's (NDOT) freeway service patrol program; NDOT's statewide crash database; the Nevada Highway Patrol's computer-aided dispatch system; the Northern Nevada Road Operation Center; and the Freeway and Arterial System of Traffic. A step-by-step process for integrating data from the various sources was developed and implemented. A number of challenges and limitations associated with the data were identified. Finally, a prototype dashboard was developed that displays a variety of aggregate and disaggregate TIM performance measures. Recommendations for filling some of the data gaps are provided.			
17. Key Word Traffic incident management (TIM), performance measures, clearance time, secondary crash, data integration, dashboard		18. Distribution Statement Unrestricted. This document is available through the National Technical Information Service, Springfield, VA 21161	
19. Security Classif. (of this report) Unclassified	20. Security Classif. (of this page) Unclassified	21. No. of Pages 78	22. Price

---

## ACKNOWLEDGEMENTS

The authors would like to thank the following individuals and groups for their assistance and support throughout the research project:

- Seth Daniels, Nevada DOT
- Kim Edwards, Nevada DOT
- Juan Hernandez, Nevada DOT
- Alexander Wolfson, Nevada DOT
- Gang Xie, FAST
- Brian Hoeft, FAST
- Doug Ashmore, Spillman Technologies
- Northern and Southern Nevada TIM Coalitions
- Tom Wright, Kentucky Transportation Cabinet
- Jennifer Walton, University of Kentucky
- Tim Emington, Northrop Grumman (TRIMARC)
- Jonathan Nelson, Missouri DOT
- Lisa Vieth, Missouri DOT
- Darin Weaver, Oregon DOT
- Chris Wright, Oregon DOT
- Nathaniel Price, FHWA

---

# TABLE OF CONTENTS

Acknowledgements.....	iii
List of Figures .....	v
List of Tables .....	vi
Executive Summary.....	vii
1. Introduction .....	1
1.1. Background .....	1
1.2. Problem Description .....	1
1.3. Objectives of Research.....	2
1.4. Scope of Work.....	3
2. State of the Practice in TIM Performance Measurement and Reporting.....	4
2.1. Overview of Approach .....	4
2.2. Summary of Findings.....	5
2.3. Summary of Gaps.....	16
3. Assessment of the Quality and Quantity of Incident Data .....	18
3.1. Overview of Approach .....	18
3.2. Summary of Findings.....	18
4. Development of a Prototype TIM Performance Measurement Database .....	24
4.1. Data Integration .....	24
4.2. Results.....	28
4.3. Challenges .....	30
5. Prototype TIM performance dashboard .....	32
5.1. Approach.....	32
5.2. Overview of Nevada Prototype TIM Performance Measures Dashboard .....	36
6. Summary and Recommendations Towards Implementation .....	48
6.1. Summary .....	48
6.2. Recommendations .....	48
References .....	51
Appendix A – Interview Questions.....	53
Appendix B – Case Studies.....	54
Oregon TIM Performance Measurement Case Study .....	54
Kentucky TIM Performance Measurement Case Study .....	59
Missouri TIM Performance Measurement Case Study .....	61
Appendix C – Checklist of TIM Data Elements by Source .....	65

---

## LIST OF FIGURES

Figure 1. Incident Timeline .....	6
Figure 2. Trends of TIM Self-Assessment Performance Measure Reports from 2012 to 2015 .....	14
Figure 3. Incident Datasets Assessed .....	23
Figure 4. Data Integration Process.....	24
Figure 5. Nevada TIM Performance Analysis Data “Funnel” .....	28
Figure 6. Extract from West Michigan Traffic Operations Center’s October 2014 Performance Measures Report .....	32
Figure 7. Fourth Quarter Incident Clearance Extracted from VDOT’s Hampton Roads TOC Fourth Quarter 2012 Performance Measures Report.....	33
Figure 8. Average SSP Incident Clearance Trends Extracted from VDOT’s Hampton Roads TOC Fourth Quarter 2012 Performance Measures Report .....	34
Figure 9. Examples of Four Well-Designed Dashboards .....	35
Figure 10. Nevada Prototype TIM Performance Measures Dashboard.....	37
Figure 11. Aggregate TIM Incident Statistics and Performance Measures.....	38
Figure 12. Incident Response and Clearance Trends .....	39
Figure 13. Average RCT and ICT by Incident Type.....	40
Figure 14. Average RT, RCT and ICT by Injury Severity .....	41
Figure 15. 30-60-90 Minute Roadway Clearance Performance.....	42
Figure 16. 30-60-90 Minute Incident Clearance Performance .....	43
Figure 17. FSP Assists .....	43
Figure 18. Incident Map – Statewide .....	44
Figure 19. Incident Map – Reno-Carson City and Surroundings.....	45
Figure 20. Incident Map – Las Vegas Area .....	46
Figure 21. Dashboard Filtering Capabilities .....	47
Figure 22. Map of Five Regions and 14 Districts, Respectively, in Oregon .....	54
Figure 23. District 8 Pilot – Percent of Crashes Cleared within 90 Minutes by Responder Type .....	57
Figure 24. District 8 Pilot – 90-Minute Clearance Time Performance .....	57
Figure 25. Average Time to Clear Traffic Incident – St. Louis .....	63
Figure 26. Average Time to Clear Traffic Incident – Kansas City.....	63
Figure 27. Number of Incidents and Average Time to Clear Lanes by Time of Day (2014) .....	64

---

## LIST OF TABLES

Table 1. Federal Highway Administration's National TIM Performance Measures.....	7
Table 2. Other Time-Based TIM Performance Measures.....	7
Table 3. Summary of TIM Self-Assessment Performance Measure Data from 2012 to 2015 .....	13
Table 4. Availability of Required Data Elements.....	19
Table 5. Availability of Desired Data Elements .....	21

---

# EXECUTIVE SUMMARY

## Background

Traffic incident management (TIM) programs and strategies are critical to reducing the impacts of incidents, including congestion, unreliable travel, responder safety, and secondary crashes. Yet, the benefits of TIM are not always as readily apparent as those of the capital projects with which they must often compete for funding. Capital projects are typically more attractive to decision makers and/or perceived to be more vital. Therefore, ongoing justification of TIM programs and strategies to demonstrate the value of TIM are often necessary to maintain and expand critical TIM programs and activities.

## Objectives

While there has been recent research conducted and guidance developed to support agencies in the collection and reporting of TIM performance measures, many organizations have yet to adopt TIM performance measurement as a formal process. The goal of this research project was to leverage this recent work to meet the following objectives:

1. Benchmark/validate the Nevada Department of Transportation's (NDOT) practices in the collection, analysis, and reporting of TIM performance data against the practices of other leading states/agencies and against the National Cooperative Highway Research Program (NCHRP) Project 07-20 guidance on the implementation of TIM performance measurement.
2. Assess the quantity and quality of incident data currently available across the state of Nevada.
3. Build a prototype TIM performance measurement database that contains consistent incident data from various sources across the state.
4. Build a prototype dashboard to display consistent statewide TIM performance measures calculated by querying the database.

## Approach

This project included a series of seven tasks to meet the research objectives. These tasks included a state-of-the-practice review, an assessment of current incident data sources available in Nevada, a gap analysis, and the development of a prototype TIM performance measurement database and dashboard.

## Findings

### State-of-the-Practice Review

A literature review and selected interviews with several leading state agencies helped to establish the state-of-the-practice in TIM performance data collection, analysis, and reporting. The findings are presented according to the following TIM performance measurement and management activities:

- Performance measures collected/reported
- Data collection, sharing, and integration
- Data analysis and reporting



- 
- Methods for incorporating TIM into future decisions
  - Communications and coordination

Following the review, a number of gaps were identified between the TIM performance measurement and reporting practices in Nevada and those of other leading peer agencies. These gaps included:

- There is little sharing or integration of data for TIM performance measurement in Nevada. Although the Freeway and Arterial System of Traffic (FAST) is co-located with Nevada Highway patrol (NHP) (and NDOT), the FAST dashboard system is not integrated with the NHP computer-aided dispatch (CAD) data. FAST does monitor an NHP website that posts active incidents; however, this website only provides basic information. From a law enforcement perspective, NHP does not collect any specific data for TIM performance measurement.
- Outside of FAST's database and dashboard system, which covers the Las Vegas area, NDOT lacks the systems and data to support comprehensive TIM performance analysis.
- Although FAST is doing well in Las Vegas with blending congestion and incident data to determine how an effective TIM program contributes to maintaining system reliability, there is little use of TIM performance analysis to support TIM performance management and decision-making in Nevada.
- Overall communications and coordination is strong in Nevada, particularly with the TIM coalitions in Las Vegas and Reno; however, there have been few discussions centered on measuring and reporting TIM performance or the importance thereof.
- The FAST dashboard interface allows operators to capture secondary crashes; however, there may be room for improvement from revisiting the process used to identify secondary crashes to ensure that accurate and credible data are collected. The resulting data can be inconsistent.
- Typically, at FAST, once an incident is cleared from the roadway, it is no longer tracked. FAST's challenges with collecting incident clearance times (ICTs) are primarily related to staffing resources. It was reported that increased coordination with NHP and other responders would be necessary to begin collecting and reporting ICTs from field personnel.

## Data Assessment

Five different sources of incident data were assessed to determine the quantity and quality of incident data available across the state of Nevada, including:

- FAST – all incidents between the last quarter of 2009 and the first quarter of 2015
- NDOT's Northern Nevada Road Operation Center (NNROC) – "significant" incidents only from January 2014 to June 2015
- NDOT's freeway service patrol (FSP) programs in Las Vegas and Reno – incidents between October 2013 and April 2015
- NDOT crash database – crashes from January 2013 to February 2015
- NHP CAD system – crashes from 2013 and 2014

The quantity of data was assessed in terms of the total numbers and coverage of incidents in each dataset. The quality of the data was assessed using the NCHRP 07-20 data model and the corresponding "TIM PM checklist" as a benchmarking tool.

---

Based on the assessment, the NHP CAD data combined with the crash data provide the most comprehensive source of incident data for analyzing TIM performance; however, these datasets need to be merged and leveraged for this purpose (which they currently are not). Law enforcement is involved in the most incidents statewide; however, considering the various data elements available in each of the datasets, simply having the most incidents is not necessarily the best. For example, there are more incidents in the NDOT crash database than in any of the other databases, and the crash data contain several descriptive data elements not found in the other datasets (e.g., weather and lighting conditions); however, the crash database does not include time stamps to calculate roadway clearance times (RCTs) or ICTs, nor does it include secondary crashes. Therefore, none of the three national TIM performance measures can be calculated using the crash data alone. Similarly, the FSP assist database contains a large number of assists, but it lacks adequate location details. On the other hand, the FAST database contains location details, the time at which the roadway is cleared, and secondary crashes, but lacks a comparative magnitude of incidents to FSP and NDOT. The NHP CAD data – also statewide – provide many of the critical time stamps (e.g., time of first awareness, time incident verified, time of arrival on scene, time roadway lanes cleared, time incident cleared (when NHP was last to depart the scene)) as well as other data elements that can be used in performance analyses, but is not directly accessible by NDOT for performance analyses.

It was clear from the data assessment that in order for NDOT and the Nevada TIM partners to evaluate TIM performance on a statewide basis, that integration of the various databases was a necessary activity.

### Data Integration

As none of the assessed data sources contained all of the required and desired data elements necessary for a robust TIM performance analysis, it was necessary to integrate the incident data from the various data sources into a single database to allow the calculation of the TIM performance measures. Therefore, a step-by-step process was developed to integrate the incident data from the various datasets.

The process of integrating the data was successful, but telling, in terms of the quantity of data available to NDOT and the Nevada TIM partners for TIM performance analysis. The results showed the ability to calculate RT on slightly more than one-third of the NDOT-NHP integrated crashes, ICT on 20 percent of the NDOT-NHP integrated crashes, and RCT for about 2 percent of the NDOT-NHP crashes. Additionally, while calculating RT and ICT for the FSP data is possible, the way in which the incident timeline is recorded is not necessarily consistent with the Federal Highway Administration's (FHWA) definitions and may lead to misleading results.

The biggest barrier for NDOT in calculating the TIM performance measures on a statewide basis is that incident data are not always collected with the TIM performance measures in mind (specifically for the purpose of TIM performance analyses). Therefore, the required and desired data elements for TIM performance analyses are not readily available in the existing databases. Making a concerted effort towards collecting these data elements through the crash form, via the responding agencies' CAD systems, and by the FSP will greatly improve NDOT's ability to assess and report on TIM performance statewide. The integration of the data provided a subset of the incident data (which did represent a statewide sample of incidents) for which TIM performance could be analyzed and reported.

### Prototype TIM Performance Measurement Dashboard

The goal for the prototype Nevada TIM performance dashboard was to provide a snapshot of a wide range of performance measures, both at an aggregate level and at a more disaggregate level. The

---

approach was to examine how other leading agencies report and visualize TIM performance, examine a variety of dashboards from other disciplines, and design a mock-up for Nevada’s TIM performance measures dashboard.

Using the basic dashboard design principles and visualization ideas from other dashboards, an initial mockup of the Nevada TIM performance dashboard was developed. Based on TIM performance guidance from FHWA, the findings from other states’ TIM performance reporting, and measures/reporting specific to Nevada, the primary information to be conveyed on the prototype dashboard included:

- Aggregate incident and performance statistics (e.g., incident, injury, and fatality counts; average response time (RT), RCT, and ICT)
- Performance measures appropriate for both urban and rural incidents
- Disaggregate performance statistics (to provide context) (e.g., average response and clearance times by incident type and injury severity)
- Performance trends (e.g., average response and clearance times by month)
- 30-60-90 clearance times (similar to what FAST produces and reports to NDOT)
- Maps of incident locations with corresponding performance measures

After the initial mock-up was created, queries were run on the data in the TIM performance measures database to produce the associated numbers and graphs to populate the mock-up dashboard.

An interactive prototype TIM performance dashboard was developed and demonstrated to the Nevada TIM partners. The prototype dashboard provides consistent TIM performance measures (including aggregate and disaggregate measures of performance) for incidents across the state, and the measures are calculated by querying the integrated database. The prototype dashboard allows users to filter TIM performance analyses by a number of factors including timeframe, location, urban vs. rural, and weather conditions.

## Conclusions and Recommendations

The results of this pilot project are intended to assist Nevada in developing, collecting, and reporting consistent, statewide TIM performance measures. The findings presented in this report can be used by NDOT and its TIM partners to find and assess new/different and more effective ways of collecting and managing incident data for the purpose of TIM performance analysis. The findings can help NDOT and its TIM partners to better understand which of the required and desired TIM performance data elements are available in each dataset, as well as where the data gaps are that need to be filled.

Recommendations for improving the quantity and quality of the incident data include:

- *Focus on improving the times and locations of the incidents, the most critical data elements for analyzing TIM performance* – The time stamps associated with the incident timeline (and consistent with the FHWA definitions) are absolutely critical for calculating the TIM performance measures. In addition, the exact incident location, in terms of latitude and longitude, is also critical in order to geo-locate the incident, filter for performance analyses (e.g., by NDOT district), and identify other data elements associated with the incident. Good quality geo-coordinates can be post-processed using reverse geocoding and a GIS service to automatically

---

infer many other data fields, including roadway name, city, county, state, and even weather information (if known in conjunction with the incident time).

- *Obtain and integrate additional responder data (e.g., fire, EMS, towing)* – While transportation agencies and state police collect a lot of data on a lot of incidents, they will likely not have specific data elements associated with other responders, and there are many incidents throughout the state in which neither the state DOT nor the state police are present. For example, there were over 48,000 crashes from the Las Vegas Metropolitan Police Department (LVMPD) alone, and these could not be included in the data integration process because the LVMPD CAD data were not available. This represents a very large gap in crashes from the TIM performance analysis. In addition, from early conversations with the Clark County Fire Department (CCFD), it was determined that the CCFD CAD data would provide additional details about incidents, such as the type/severity of the incidents and the number of and arrival/departure times of fire personnel/vehicles on the scene. Obtaining and integrating the LVMPD and the CCFD CAD data with the NDOT-NHP-FSP database will improve not only the quantity of the data, but also the quality of the data, and will add value to the TIM performance analyses.
- *Work to improve the collection of other desired TIM PM data elements* – Currently there are many gaps in the data as compared to the NCHRP 07-20 data model. Data elements such as the total number of lanes at the scene, the number of lanes blocked, and the number of participants/vehicles/responders involved would add value to the TIM performance analysis and the determination of when and where improvements are needed.
- *Standardize use of call/incident numbers for incidents* – To ease the data integration process, NNROC, FAST, and the FSP should collect the call or incident number used by the other responders (e.g., NHP) at the incident scenes. Recording this information would allow the TMC data to be more effectively merged with the other responding agencies' incident data by avoiding the creation of duplicate entries in the TIM PM database and facilitating the matching of FAST incident records with NHP incident records.
- *Identify secondary crash cause* – Linking a secondary crash to its parent crash/incident in the data by collecting the parent crash/incident ID when recording the secondary crash information would be valuable. It would allow for parent crashes/incidents to be identified, and for common patterns or situations leading to secondary to be uncovered by examining them separately from the rest of the incidents.
- *Leverage external datasets* – Unless required for other purposes, the collection of weather information, for example, is unnecessary and too limited. Relying on external datasets to get more detailed information (assuming time and location is known) is a better and more reliable approach. Eventually traffic conditions, local events, etc. could also be added to the data to further refine the TIM PM analysis.
- *Move towards full implementation* – While just a pilot study and a prototype database and dashboard, the outputs of this research project have established a solid foundation and platform on which NDOT can build. Specific recommendations on working towards full implementation of the TIM PM database and dashboard include:
  - Adjust policies and requirements to optimize TIM data collection at each data source/partner.

- 
- Develop and standardize data ingestion processes for each of the data sources/partners so that they are standardized and repeatable.
  - Deploy a full-size database either on premise or in the cloud to store integrated TIM data.
  - Implement a reporting/dashboard system to visualize/report TIM performance and trends.
  - Develop TIM PM reports and custom analyses to be run on the reporting/dashboard system.
  - Define and set up reporting/dashboard system users, their access rights, and their associated report delivery schedules.
  - Perform regression and performance testing on the data ingestion/integration processes and the database/reporting/dashboard system.
  - Develop and set up ingestion processes, a database, and a monitoring system to ensure stable and acceptable system performance and to perform system maintenance (archive older TIM data, retire unused reports and dashboard components).

---

# 1. INTRODUCTION

## 1.1. Background

Traffic incident management (TIM) programs and strategies are critical to reducing the impacts of incidents, including congestion, travel time reliability, responder safety, and secondary crashes; however, the benefits of TIM are not always as readily apparent as those of the capital projects with which they must often compete for funding. Capital projects may be more attractive to decision makers and/or perceived to be more vital. Therefore, ongoing justification of TIM programs and strategies – proving the value of TIM – is needed to help keep these critical activities in place.

For over a decade, FHWA has supported the advancement of TIM performance measurement to better convey the return on investment from TIM programs. To provide consistency in TIM performance measures, FHWA sponsored the 2005-2009 Focus State Initiative, which involved 11 participating states and resulted in three standard TIM performance measures: RCT, ICT, and secondary crashes. In 2011, FHWA conducted the TIM Performance Metric Adoption Campaign in which TIM-specific metrics from 40 metropolitan areas were gathered and examined for consistency with FHWA definitions. This project also established a national baseline for the three standard TIM performance measures and recommended methods for maintaining and expanding TIM performance measurement nationwide [1].

More recently, the Transportation Research Board (TRB) sponsored the NCHRP Project 07-20: *Guidance for the Implementation of TIM Performance Measurement* [2]. The objective of this project was to provide guidance on the consistent use and application of TIM performance measures, including a model TIM performance measures database schema, scripts, and example applications, reporting, and visualization of TIM performance measures. The products of this project include a written guidance document and a web-based version of the guidance, both of which are available via the TIM Network website at: <http://nchrptimpm.timnetwork.org/>.

NDOT launched a unified TIM program in 2008, which is divided into three TIM coalitions: northern urban, southern urban, and statewide. The northern and southern coalitions focus primarily on urban issues, and the statewide coalition focuses on rural issues. NDOT reports on several performance measures (particularly in the northern and southern urban centers), including time of vehicle removal to the shoulder (or RCT), number of incidents, number of incidents managed, number of incidents on the shoulder in 10 minutes or less, incidents that block two or more lanes, and travel time. The majority of incidents are reported via traffic management or operations center (TMC/TOC) operators and 911 dispatches. In the northern urban center, incident monitoring and management is accomplished through the Northern Nevada Regional Road Operations Center (NNROC). In the southern urban center, incident monitoring and management is accomplished through Southern Nevada's FAST. FAST shares TIM data in a monthly report to NDOT.

TIM performance measures can be useful in helping to justify investments in TIM programs and strategies. In addition, MAP-21 will place requirements for the reporting of a number of performance measures, including congestion and safety, both of which can be directly impacted by the application of sound TIM principles.

## 1.2. Problem Description

Despite the research and guidance put forth to date, many organizations have yet to adopt TIM performance measurement as a formal process. Barriers and challenges to TIM performance

---

measurement can include a lack of consensus among TIM agencies, a lack of supporting data, incompatible systems, and concerns over data confidentiality and system security [3] [4] [5]. Even amongst the states and local areas that are actively measuring TIM performance, there are a range of practices with respect to TIM performance data collection, analysis, and reporting, resulting in non-uniform reporting practices.

The 2013 *Traffic Incident Management National Analysis Report* summarizes the findings from the TIM Self-Assessment (TIM SA), a benchmarking tool for evaluating TIM program components and overall TIM program success [6]. According to this report, the questions on TIM performance measurement have consistently been among the lowest scoring questions on the TIM SA. Amongst the 93 TIM SAs that were completed in 2013, four of the five questions receiving the lowest mean score were from the subsection on TIM performance measurement. These TIM SA scores highlight a need for special attention on collecting and analyzing data relating to performance measures, particularly secondary incidents.

What is needed is to take the recent research and guidance on the standardized collection and reporting of TIM performance to the next level by conducting a pilot project that will highlight and further guide the implementation of TIM performance measures nationally.

### 1.3. Objectives of Research

The technical objectives of this research project were to leverage recent research and guidance on TIM performance measurement to:

1. Benchmark/validate NDOT's practices in the collection, analysis, and reporting of TIM performance data against the practices of other leading states/agencies and against the NCHRP Project 07-20 guidance on the implementation of TIM performance measurement.
2. Assess the quantity and quality of incident data currently available across the state of Nevada.
3. Build a prototype TIM performance measurement database that contains consistent incident data from various sources across the state.
4. Build a prototype dashboard to display consistent statewide TIM performance measures calculated by querying the database.

The results of this pilot project are intended to assist Nevada in developing, collecting, and reporting consistent, statewide TIM performance measures. The statewide TIM performance measurement database is also intended to be leveraged for other purposes, such as the analysis/quantification of the impacts of incidents (e.g., congestion, delay, travel time reliability, emissions, fuel savings) and the calculation of the return-on-investment/benefit-cost ratio for TIM programs and strategies, such as NDOT's FSP program.

---

## 1.4. Scope of Work

The scope of work for this research project included nine tasks that were undertaken to meet the four technical objectives presented above. This report details the approach and outputs/findings of each task and is organized around the technical objectives as follows:

- **Chapter 2 – State of the Practice in TIM Performance Measurement and Reporting** – Chapter 2 describes the approach to conducting the state of the practice review, which included a literature review and telephone interviews with selected agencies. These activities were conducted to address the *first objective* of benchmarking NDOT’s practices against the practices of other leading states/agencies. The findings from the literature review and agency interviews are discussed in the context of the TIM performance measures collected/reported; data collection, sharing, and integration; data analysis and reporting; TIM performance management practices; and communications and coordination amongst TIM agencies. Chapter 2 concludes with a summary of the gaps that were identified between the TIM performance measurement and reporting practices in Nevada and those of other leading peer agencies.
- **Chapter 3 – Assessment of the Quantity and Quality of Incident Data** – Chapter 3 details the approach and findings associated with an assessment of the quantity and quality of incident data available in Nevada at the time of the task. The data sources assessed are described and the corresponding data elements are compared to those included in the NCHRP 07-20 TIM performance data model using the “TIM PM checklist.” These activities were conducted to address the *second objective* of assessing the quantity and quality of incident data in Nevada. The chapter concludes with an overall assessment of the quantity and quality of incident data available for integration into a prototype TIM performance measurement database.
- **Chapter 4 – Development of a Prototype TIM Performance Measurement Database** – Chapter 4 details the approach and step-by-step process used to integrate the various datasets into a prototype TIM performance measurement database. These activities were conducted to address the *third objective*. Challenges associated with integrating the existing datasets are identified, and the results are presented in terms of the quantity of data available overall, as well as the quantity available for various TIM performance analyses after integration.
- **Chapter 5 – Prototype TIM Performance Dashboard** – Chapter 5 presents and describes the approach to developing the prototype Nevada TIM performance dashboard, including a review of dashboard design principles, best practices, and other dashboards. These activities were conducted to address the *fourth objective* of developing a prototype TIM performance dashboard. Examples of TIM reporting from other states are shown, as well as examples of well-designed dashboards. Finally, the prototype TIM performance dashboard is presented, and each part of the dashboard is described in detail.
- **Chapter 6 – Summary and Recommendations towards Implementation** – Chapter 6 presents a summary of the research and findings and discusses recommendations for improving the incident data in Nevada, and next steps for taking the prototype database and dashboard to the next level, including live implementation.



---

## 2. STATE OF THE PRACTICE IN TIM PERFORMANCE MEASUREMENT AND REPORTING

The first objective of this research project was to benchmark and validate NDOT's practices in the collection, analysis, and reporting of TIM performance data against the practices of other leading states/agencies. This chapter describes the approach that was taken to meet this objective and provides a summary of the findings.

### 2.1. Overview of Approach

Two approaches were taken to gather information on agency practices associated with TIM performance measurement: (1) a literature review and (2) interviews with selected agencies.

#### 2.1.1. Literature Review

As part of two recent projects focused on TIM performance measurement, the authors of this NDOT report compiled and reviewed the most relevant literature on the topic. The first project was the TRB's NCHRP Project 07-20. The output of this project was a guidance document and online tool on the implementation of TIM performance measurement [2]. The second project was conducted in support of FHWA's efforts towards the institutionalization of TIM performance measurement and included the development of a step-by-step process for implementing a TIM performance measurement program [7]. A third literature review was conducted in 2015, as a part of NCHRP Project 03-108: Guidance on Quantifying Benefits of TIM Strategies [8]. The full bibliography, as well as a comprehensive summary of the literature, was shared with the research team for this project. To conserve both project time and funds for this project, the approach was first to capitalize on the information from these literature reviews and then to search for any newer, relevant information that had been published since these reviews were conducted. For the latter, a search was conducted of TRID, TRB's integrated database, which combines the records from the Transportation Research Information Services (TRIS) Database and the Joint Transport Research Centre's International Transport Research Documentation (ITRD) Database. TRID provides access to more than one million records of transportation research worldwide. The search produced seven new sources, at varying levels of relevance, since the last literature reviews had been conducted.

The information gathered from this literature review is dispersed throughout the summary of the findings in Section 2.2.

#### 2.1.2. Agency Interviews

As part of the previously mentioned FHWA effort towards the institutionalization of TIM performance measurement, telephone interviews were conducted with ten public agencies. The primary objective of these interviews was to identify good data collection methods, practices, techniques, and technology systems, with particular focus on locations where law enforcement data are being collected in support of TIM performance analysis and reporting. The ten agencies interviewed included:

- Arizona Department of Public Safety (AZDPS)
- Florida Department of Transportation (FDOT)
- Freeway and Arterial System of Traffic (FAST)
- Michigan Department of Transportation (MDOT)

- 
- Minnesota Department of Transportation (MnDOT)
  - New York State Department of Transportation (NYSDOT)
  - Tennessee Department of Transportation (TDOT)
  - Virginia Department of Transportation (VDOT)
  - Washington State Department of Transportation (WSDOT)
  - Wisconsin Department of Transportation (WisDOT)

The information gained from these interviews was used to develop a guide for responder agencies, titled: “Process for Establishing, Implementing, and Institutionalizing a Traffic Incident Management Performance Measures Program” [7]. In addition, the information was used to develop case studies for each of these organizations. These case studies are available on the *TIM PM* website at:

[http://nchrptimpm.timnetwork.org/?page\\_id=69](http://nchrptimpm.timnetwork.org/?page_id=69).

As these efforts were conducted by the research team for this NDOT project, the approach here was to supplement the information by conducting additional interviews with the following three agencies:

- Kentucky Transportation Cabinet (KTC)
- Missouri Department of Transportation (MoDOT)
- Oregon Department of Transportation (ODOT)

The findings from all 13 interviews are dispersed throughout the summary of the findings in Section 2.2. A full list of interview questions is included in Appendix A, and case studies for the three interviews that were conducted as a part of this project are included in Appendix B.

## 2.2. Summary of Findings

This section presents the findings from the literature review and the agency interviews. The findings are discussed according to the following TIM performance measurement and management activities:

- Performance measures collected/reported
- Data collection, sharing, and integration
- Data analysis and reporting
- Methods for incorporating TIM into future decisions
- Communications and coordination

### 2.2.1. Performance Measures Collected/Reported

#### 2.2.1.1. *TIM Performance Measures*

With the input of 11 states as part of the Focus State Initiative, FHWA established and defined three national TIM performance measures: RCT, ICT, and secondary crashes. RCT begins at the time of the first recordable awareness of an incident and ends at the time when all lanes are available for traffic flow. ICT also begins at the time of the first recordable awareness of an incident but ends at the time when the last responder has left the scene [9]. The incident timeline depicted in Figure 1 shows RCT, ICT, and other TIM performance measures, such as incident detection time (IDT), incident verification time (IVT), and RT, as well as the time to return to normal flow [10].

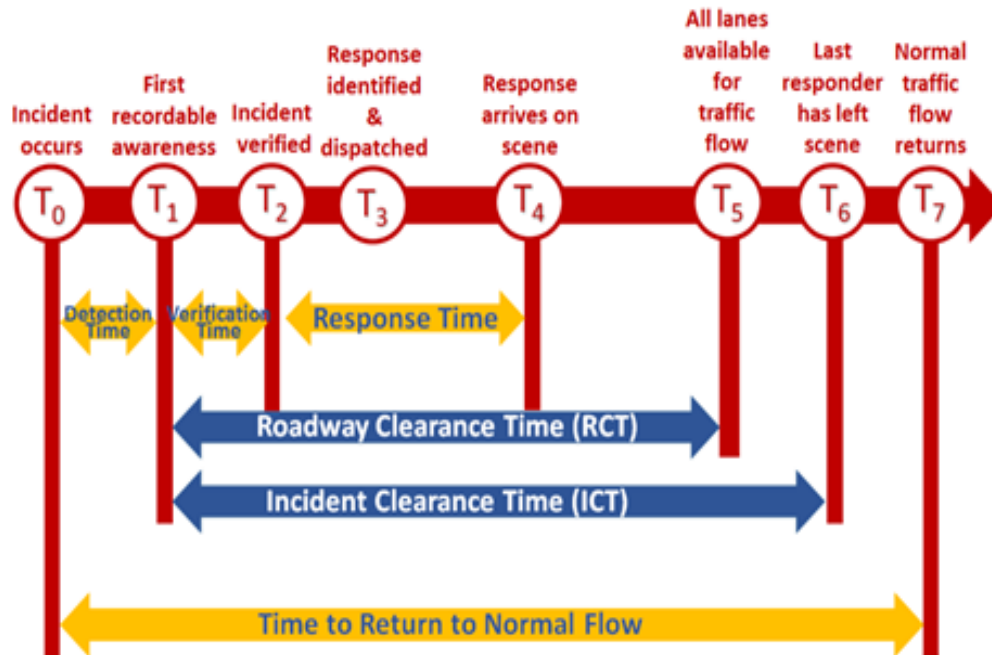

Figure 1. Incident Timeline

More detailed information, including the definitions and required data elements, for the three national TIM performance measures is provided in Table 1. Having a national standard for TIM performance measures allows for the analysis of national incident response trends and the assessment of TIM programs across the boundaries of any given region [7].

While these standard measures are important for consistency between agencies, some agencies make use of other TIM performance measures for their internal use, such as IDT, IVT, RT, and the time to return to normal flow of traffic (NFT).

Table 2 defines these measures, notes the data elements required to calculate each measure, and provides the corresponding equation.

Table 1. Federal Highway Administration's National TIM Performance Measures

Key TIM PMs	Definition	Required Data Elements	Equation
<b>Roadway clearance time (RCT)</b>	<b>Time between</b> the first recordable awareness of the incident by a responsible agency and the first confirmation that all lanes are available for traffic flow.	<b>T<sub>1</sub> = Time</b> of first recordable awareness of an incident by a responsible agency. <b>T<sub>5</sub> = Time</b> of first confirmation that all lanes are available for traffic flow.	$RCT = T_5 - T_1$
<b>Incident clearance time (ICT)</b>	<b>Time between</b> the first recordable awareness of the incident by a responsible agency and the time at which the last responder has left the scene.	<b>T<sub>1</sub> = Time</b> of first recordable awareness of an incident by a responsible agency. <b>T<sub>6</sub> = Time</b> at which the last responder has left the scene.	$ICT = T_6 - T_1$
<b>Secondary crashes</b>	The <b>number</b> or <b>percentage</b> of unplanned crashes beginning with the time of detection of the primary incident, where a crash occurs as a result of the original incident either within the incident scene or within the queue in either direction.	<b>Identification</b> of whether a crash is secondary to a primary crash/incident (e.g., yes/no).	% secondary crashes = $\left( \frac{\# \text{ secondary crashes}}{\text{Total \# crashes/incidents}} \right) * 100$

Table 2. Other Time-Based TIM Performance Measures

Other TIM PMs	Definition	Required Data Elements	Equation
<b>Incident detection time (IDT)</b>	<b>Time between</b> the first recordable awareness of the incident by a responsible agency and when the incident actually occurs.	<b>T<sub>0</sub> = Time</b> at which incident actually occurs. <b>T<sub>1</sub> = Time</b> of first recordable awareness of incident by a responsible agency.	$IDT = T_1 - T_0$
<b>Incident verification time (IVT)</b>	<b>Time between</b> when the incident is verified and the first recordable awareness of the incident by a responsible agency.	<b>T<sub>1</sub> = Time</b> of first recordable awareness of incident by a responsible agency. <b>T<sub>2</sub> = Time</b> at which incident is verified.	$IVT = T_2 - T_1$
<b>Response time (RT)</b>	<b>Time between</b> when the incident is verified and when response arrives on scene.	<b>T<sub>2</sub> = Time</b> at which incident is verified. <b>T<sub>4</sub> = Time</b> at which response arrives on scene.	$RT = T_2 - T_4$
<b>Time to return to normal flow of traffic (NFT)</b>	<b>Time between</b> when the incident actually occurs (or the first recordable awareness) and when normal traffic flow returns.	<b>T<sub>0,1</sub> = Time</b> at which incident actually occurs. <b>T<sub>7</sub> = Time</b> of first recordable awareness of incident by a responsible agency.	$NFT = T_7 - T_0$ or $NFT = T_7 - T_1$

---

Beyond these time-based TIM performance measures, some states collect other performance measures to track TIM performance within their states. The following list contains some examples of TIM performance measures that are tracked by various states [2]:

- Number of incidents
- Frequency of incidents
- Incident delay
- Times related to the closure/opening of individual lanes
- Severity of incidents
- Number of fatalities
- Service patrol statistics (e.g. roadway miles covered, number of assistance calls, etc.)
- After-action statistics (e.g. number of reviews, percent of participating agencies, etc.)
- Travel delay
- Queue length
- Number of secondary incidents as a result of a primary crash
- Number of secondary incidents involving first responders
- Percentage of fatal crashes that is secondary

The Wisconsin Department of Transportation (WisDOT) is exploring a number of other TIM performance measures including the following [7]:

- Safety – Beyond secondary crashes, WisDOT tracks other safety components of incidents, particularly unsafe practices such as the incorrect use of traffic control devices (TCDs) or failure to wear high visibility apparel.
- Communications/coordination – After an incident is cleared, WisDOT scores the incident in terms of the level of communications and coordination during the events.
- Incident impact – WisDOT is investigating ways in which to quantify the overall impact that incidents have on traffic and track how it varies by demand, time of day, and location. Although an incident may be minor, it could have significant impacts if it occurs in a metropolitan area during the peak period.
- Work flows and processes – WisDOT is using work flows and processes to identify points during the incident response timeline where efficiencies could lead to significant overall improvements.

Another example is the Virginia Department of Transportation (VDOT), which collects and analyzes a wide variety of TIM performance measures, including the following [2]:

- Total number of incidents
- Number of incidents and number of incidents by location, type, time of day, and district
- Number of incidents by priority (minor, major, high profile) (auto-generated by the VaTraffic database based on information entered by user)
- Total number of Safety Service Patrol (SSP) responses and SSP responses by incident type and roadway
- Number of lane closures
- Number of incidents involving tractor-trailer trucks

- Crash hot spots by incident type
- Percentage of incidents cleared by time category (<30 min, 30-60 min, 60-90 min, >90 min)
- Percentage of incidents >30 min
- Percentage of incidents >60 min
- Percentage of incidents >120 min
- Top 3 crashes with longest duration

#### 2.2.1.2. *Data Sources*

The primary sources of data for TIM performance measures are transportation (e.g., TMCs and FSPs), law enforcement data [e.g., crash reports and computer-aided dispatch (CAD) systems], or some combination of the two (e.g., TMC-CAD system integrations). In most cases, however, transportation agencies take the lead on collecting the data. As a result, TIM performance measures data are not usually collected or reported beyond urban areas due to a lack of intelligent transportation system (ITS) coverage. The state of the practice has recently evolved to involve the collection/reporting of TIM performance measures data by law enforcement, and it has significantly increased the amount of data available for TIM performance measurement for those regions/states that have taken this route. Arizona, Florida, and Tennessee have incorporated the required data elements for the three national TIM performance measures into their respective electronic crash reporting software systems [7]. Other data sources that can also be useful for TIM performance measures are fire and emergency medical services (EMS) CAD systems, towing systems, 511 systems, public-safety answering points (PSAPs), and social media/crowd sourcing applications [7].

#### 2.2.1.3. *Challenges with TIM Performance Measures Data Collection*

While the FHWA definition of ICT includes the time in which the last responder of any type has left the scene, agency practices for this performance measure vary due to the challenges associated with identifying and recording this time [1]. When incidents occur within a TMC coverage area, TMC operators monitoring incidents can view (via CCTVs) or communicate with field personnel regarding the time that the last responder leaves the scene. While this is a practice at many TMCs, not all record this time for various reasons, including a shortage of resources. This challenge also exists when law enforcement is responsible for collecting the data, as law enforcement officers are not always the last to leave incident scenes. AZDPS reports that in the large majority of incidents, law enforcement is indeed the last to depart the scene, and when it is not, the clearance time is generally shared with AZDPS and entered into the database at a later time [7].

The collection of secondary crashes has proven to be one of the biggest challenges with the national TIM performance measures. While some agencies have adopted FHWA's definition and actively collect secondary crash data, other agencies feel there is too much subjectivity in the definition and would like it to include a spatial and/or temporal component. FHWA's guidance on this matter is that those recording secondary incidents should use their best judgement, and that it is better to have some data on secondary crashes than no data. In addition, there is not consensus on which type of organization – transportation or law enforcement – is better suited to determine whether a crash is secondary in nature.

Using CCTV cameras, operators at some TMCs, including FAST in Las Vegas and the Niagara International Transportation Technology Coalition (NITTEC) in Buffalo, New York, identify crashes that have occurred in the queues of previous crashes or incidents and simply check a box on the incident entry screen;

---

however, TMC operators cannot view every incident. VDOT believes that the determination must occur at the incident scene, and therefore does not collect secondary crash data at its TOCs. In Arizona, every secondary crash is documented by state and local law enforcement. Officers have been trained on the definition, and there is a designated field on the crash report to document secondary crashes [7].

AZDPS began this process by adding the TIM performance measures as supplemental fields in their Traffic and Criminal Software (TraCS) electronic crash reporting software, first conducting a pilot test in the Phoenix area. Later, working through the State's Traffic Records Coordinating Committee (TRCC), the TIM performance measures were added to the Arizona statewide crash form. AZDPS believes that officers on the scene are in the best position to determine if an incident is secondary. Other law enforcement agencies, including the Tennessee Highway Patrol (THP) and the Florida Highway Patrol (FHP), also collect secondary crash data on their respective crash forms [7].

Beyond transportation and law enforcement data, there are other data sources that agencies either use, are exploring, or could use to better understand their TIM performance, including fire and EMS CAD systems, towing services, 511 systems, PSAPs, and social media/crowdsourcing apps [7]. Both VDOT and the Florida Department of Transportation (FDOT) are exploring the use of Waze, a popular example of a crowdsourcing application, as a source of incident information. Waze is a community-based traffic and navigation app that encourages users to input information about the activities happening along their routes. FDOT notes that while the TMCs are quicker to identify incidents within their coverage areas than via Waze, the use of Waze has allowed them to more quickly identify incidents outside of their coverage areas than they would without the data [7].

#### 2.2.2. Data Collection, Sharing, and Integration

Three general models for collecting TIM performance measures are commonly used across the country: (1) a transportation agency as the lead, with transportation data as the primary data source; (2) law enforcement as the lead, with law enforcement data as the primary data source; and (3) some combination of the first two. Within each of these three models, there are several variants as to how the data are collected and shared [7].

Most states use the first general model, relying on their TMCs to capture data for TIM performance measurement. The data collection typically begins when the transportation agency TMC operators become aware of an incident through the network of ITS devices or via a call and begin tracking and monitoring the incident. The TMCs typically have either an ATMS or other electronic incident tracking system to log the incident data. In some cases, the transportation agency also uses its FSP as a data source. In these cases, the incident data are communicated from FSP personnel at the scene via radio to the TMC, at which point the information is logged into the system by a TMC operator. In some cases, FSP personnel enter incident data remotely in the field. For example, in Washington State, data entered remotely by Incident Response (IR) teams are auto-populated into the Washington State Department of Transportation's (WSDOT) statewide database, the Washington Incident Tracking System (WITS). Similarly, in New York, the Region 1 HELP FSP has mobile data terminals (MDT) that are connected to the TMC. The data entered into the MDTs are automatically populated into the TMC database [7].

The second general model for collecting TIM performance measures involves a law enforcement agency lead role, most likely the state police or highway patrol. Under this model, incident data are collected by law enforcement officers at incident scenes using a standard crash form or an electronic crash reporting system. AZDPS has taken the lead in Arizona on the collection of TIM performance measures. At the end of each shift, officers electronically submit the records to AZDPS's database. The data are migrated

---

daily from AZDPS to Arizona Department of Transportation's (ADOT) database using an XML web service. The FHP also collects the three national TIM performance measures statewide through its CTS electronic crash reporting software; however, FDOT is still the lead agency in reporting the TIM performance measures [7].

The third general model for collecting TIM performance data is a combination of transportation and law enforcement, and this model varies between the states that have adopted or evolved into this approach. Generally speaking, the data are collected by the state DOT; however, the information collected by the DOT is supplemented through sharing or integration with one or more law enforcement CAD systems. Integration is generally achieved through a direct feed from the CAD system into the DOT/TMC, at which point the data are either automatically entered into the system or the TMC operators manually enter it into the system [7].

Many agencies have found that having a statewide incident database allows more capability and flexibility in the analysis and reporting of TIM performance. Examples of agencies that have statewide databases where all TMCs throughout the state use the same system to report incidents are VDOT, WSDOT, and the Tennessee Department of Transportation (TDOT). Having a statewide database typically requires that all incidents be input in the same format, which leads to consistent data collection practices throughout the TMCs in the state. The statewide databases also allow states to look at data from a regional or statewide perspective. VDOT's VaTraffic is a robust statewide incident database that allows for the development of detailed regional performance reports for its TIM program. WSDOT's WITS database is another example of a robust statewide database [7].

In the New York State Department of Transportation (NYSDOT) Region 8, the TMC operations floor has a live CAD screen from which they can draw information, but it requires manual entry into the ATMS system. Similarly, in Michigan, the Michigan State Police (MSP) are co-located with the Michigan Department of Transportation (MDOT) at the Southeast Michigan TOC (SEMTOC), and they share CAD data, albeit on separate screens. While these data are not integrated, the information does inform the TMC operators logging the incidents. For VDOT, the TOC and CAD systems are fully integrated in that the information appears on the TOC operator's screen; however, this information must be interpreted and manually entered into the TOC system by the operator. The Minnesota Department of Transportation (MnDOT) TMC in Minneapolis-St. Paul has been fully integrated with the Minnesota State Patrol (MSP) CAD system since 2008. Some of the fields for the TIM performance measures are automatically populated via the integration with MSP CAD [7].

A number of states, including Virginia, Michigan, Wisconsin, New York, and Minnesota have some level of TMC-CAD sharing or integration. This approach usually involves a Memorandum of Understanding (MOU) between transportation and law enforcement regarding the shared use of data. Interagency cooperation, funding, and technology systems all play a part as to whether and how the TMC and CAD systems are integrated [7].

VDOT has made a concerted effort to integrate data from local/regional PSAPs. While VDOT's focus is reporting TIM performance on interstate highways, VDOT has conducted more than 15 local/regional PSAP integrations across the state and is adding more. With the addition of this information, VDOT is able to capture data for about a quarter of the incidents on primary and arterial routes statewide, which has increased its awareness and knowledge of TIM performance outside of its primary TOC coverage areas. The information is very granular and varies from one PSAP to another. As much of the information is in free-form text, VDOT relies on the TOC operators to comb through the information and use their knowledge to extract what is relevant [7].



---

The Regional Transportation Commission (RTC) of Southern Nevada, through the FAST system, leads the efforts to collect, analyze, and report TIM performance in Las Vegas. FAST collects TIM performance measures data primarily through its dashboard system, which was built in-house. The dashboard provides FAST with a graphical user interface that TMC staff use to enter incident-related data, along with a powerful back-end database. Incidents are tracked using a data entry screen that appears after an incident has been located. The data in the database are stored automatically and can be queried in real-time. In addition, NDOT collects incident-related data through its NNROC in Reno and through its FSP programs in both Reno and Las Vegas, although to a much lesser extent as compared to the data collected at FAST. These various datasets are not integrated [7].

### 2.2.3. Data Analysis and Reporting

Generally speaking, TIM performance analysis and reporting is conducted by transportation agencies, as these agencies are responsible for the performance of the highway system. When it comes to TIM performance analysis and reporting, some agencies are more sophisticated than others. Some agencies simply report a single, aggregate average value for RCT and/or ICT. Others conduct more disaggregate analyses such as reporting TIM performance by incident type (e.g., crash vs. disabled vehicle), incident severity (e.g., non-injury vs. injury vs. fatality), or roadway and/or provide more detailed reports with various levels of sophisticated graphs and visualizations of the TIM performance measures [7].

One of the most common ways of reporting TIM PMs is in monthly/quarterly/annual reports. Many agencies, such as MDOT, VDOT, and WSDOT use these reporting practices on a regular basis. MDOT reports on all three national performance measures, among a number of other performance measures associated with TOC operations, for all coverage areas on a monthly basis. All of the reports are published and made available on MDOT's website. VDOT produces weekly and quarterly TIM performance reports on a regional basis. The weekly reports are typically a few pages, while quarterly reports contain significantly more information and detail. VDOT has graphs for SSP trends month to month, as well as a cumulative distribution function showing the percentage of incidents that are cleared within certain clearance goals. WSDOT uses results from the analyses of data in WITS to report on overall TIM program performance in various forms on various recurring schedules to management, administration, and the public. The *Gray Notebook* is a quarterly performance document, which is WSDOT's primary tool for reporting performance and demonstrating accountability. Updates on performance of the TIM/IR program is one of the areas reported in this document.

The consistency of the practices within a state directly impacts the reporting of the TIM performance measures. While the practices of the TMCs in many of the leading states vary between the TMCs, those that maintain some level of consistency from the top down generally do a better job of collecting and reporting the TIM performance measures. In states where each individual TMC has its own ATMS software and reporting practices, the TIM performance measures are reported less often and with less consistency. This is not necessarily a challenge that is easily overcome, as the issue stems from a number of factors including resources available, the culture within the TMCs, and technology limitations [7].

FAST's database and dashboard are relatively sophisticated systems that provide RTC and NDOT with the ability to mine incident data in many ways. Prior to this system, data were in a massive .CSV format and were processed manually. The dashboard system provides FAST with a graphical user interface that TMC staff use to enter incident-related data, along with a powerful back-end database that provides data that are ready to use. This database has allowed FAST to take a big step forward in understanding the impact of incidents and TIM performance in and around the Las Vegas metropolitan area. One of

the specific analyses that this database and dashboard system allows FAST to conduct is a “30-60-90” RCT calculation using the following categorization of incidents:

- An incident meets the 30-minute roadway clearance criterion if it involves no injuries, and it is removed from the travel lanes in 30 minutes or less.
- An incident meets the 60-minute roadway clearance criterion if injuries are involved, and it is removed from the travel lanes in 60 minutes or less.
- An incident meets the 90-minute roadway clearance criterion if it involves a fatality, and it is cleared in less than 90 minutes.

FAST uses time stamps recorded by the TMC operators on the incident entry screen as well as archived CCTV snapshot interviews to analyze incidents against these calculations. FAST reports the results of this analysis to NDOT [7].

While individual agencies employ a number of reporting methods for TIM performance in their areas, FHWA’s annual TIM SA is currently the only mechanism for reporting the TIM performance measures at the national level. The TIM SA allows agencies to report one overall (usually average) RCT and ICT for the year, as well as the overall number or percentage of secondary crashes. The TIM SA does not provide agencies with a way of reporting more disaggregate figures, such as RCT or ICT by various incident types or severities. In the large majority of cases, the data used by agencies to calculate these numbers are collected by the state DOTs via TMCs and FSP programs. Table 3 and Figure 2 summarize the number of locations that reported each of the three performance measures over the past four years on the TIM SA. While secondary crash reporting consistently increased over the four years, the number of states that reported RCT and ICT was not consistent. TIM performance measures reporting on the annual TIM SA was at its highest in 2014. Reporting in 2015 was better than 2013, but was not as high as in 2014 [11].

NDOT’s reporting of RCT on the TIM SA was fairly consistent over the four years, although no performance measures were reported in 2013. NDOT reported on secondary crashes for the first time in 2014, but did not report secondary crashes in 2015. Similar inconsistent trends can be seen in the other agencies reporting in the TIM SA. Other states, such as Washington, Oregon, Utah, New Mexico, and New York (among others), only reported certain performance measures in two or three of the four years. However, at least half of the states that report on the TIM SA do report the same measures consistently each year (e.g., California, Florida, Tennessee, and Michigan (among others)).

*Table 3. Summary of TIM Self-Assessment Performance Measure Data from 2012 to 2015*

Year	Performance Measure		
	# of states reporting RCT	# of states reporting ICT	# of states reporting SI
2012	51	43	5
2013	37	32	14
2014	56	46	18
2015	48	35	21

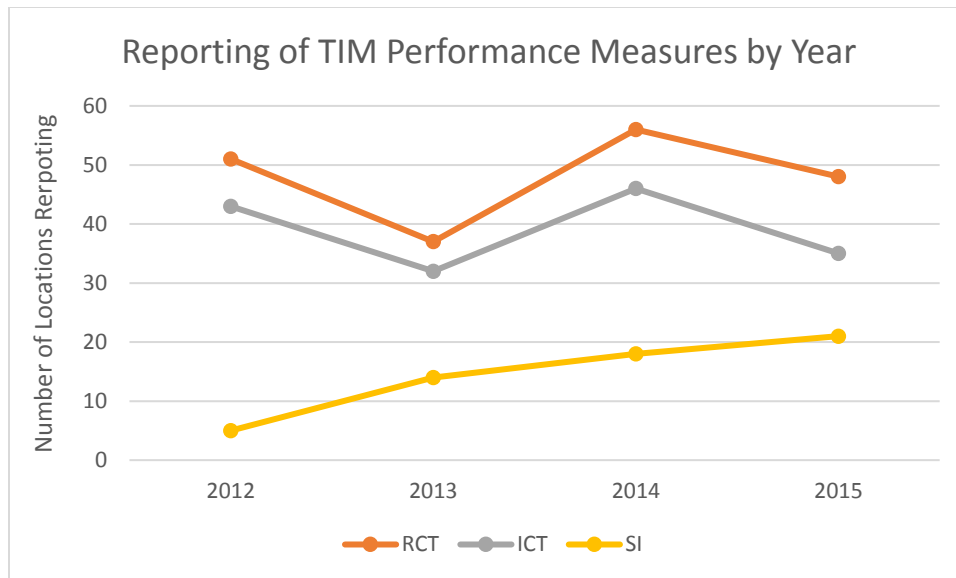

Figure 2. Trends of TIM Self-Assessment Performance Measure Reports from 2012 to 2015

#### 2.2.4. TIM Performance Management Practices

A key feature of MAP-21 is the establishment of a performance- and outcome-based program in which states invest resources in projects that collectively make progress toward the achievement of national goals, including increased safety, reduced congestion, and increased system reliability. MAP-21 will require states to set performance targets and report on the progress made toward achieving those targets. Incidents and congestion go hand-in-hand, particularly in urban areas; therefore, improving TIM performance can lead to reduced congestion. FHWA estimates that 20 percent of all crashes are secondary to a primary incident, and improving TIM performance can lead to fewer secondary crashes. In addition to saving man-hours for responder agencies, the congestion reduction impact of fewer incidents, and quicker clearance of those that do occur, allows the transportation systems to operate more efficiently [7].

Leading peer agencies all appear to have fairly strong champions that support performance measurement and management as a concept. The best candidates for being a champion are those who have a vested interest in the program’s success and who have a strong desire and passion for bringing the idea of a TIM performance measurement program to fruition. In Virginia, the regional operations director and district administrators meet regularly to determine performance targets, look at historical data, and work on definitions. The VDOT central office went through a process with regional and district stakeholders to determine the best measures to “tell the story” of the incident management process at the regional/district level for the Chief Engineer’s Report. VDOT is also working towards developing real-time analysis tools and reporting capabilities to aid in the decision-making process by showing the real-time impacts of an incident, consequences of extended lane closures, congestion impacts, detour options, etc. [7].

TDOT maintains an internal performance goal to open travel lanes within 90 min for 94% of all incidents. TDOT collects RCT data and tracks performance to ensure that it is meeting that goal. If the goal is not being met, TDOT works to determine what needs to be done to improve performance. Past examples of improvements include increased training and expanded HELP coverage areas. In addition, secondary

---

crashes are recorded by both TDOT (via the TMCs) and the state police (via TITAN electronic crash reports). Having this data has allowed the Tennessee TIM partners to identify serious secondary crashes that have occurred in the queue of a primary incident. As a result, TDOT developed a “queue protection” program to minimize secondary crashes. The program involves deploying equipment (e.g., trucks, arrow boards) and trained personnel to help protect queues that develop as a result of incidents [7].

AZDPS uses secondary crashes in the agency’s strategic plan. The police commander tracks the percent of secondary crashes over time, and if the numbers begin to increase, it is the commander’s role to determine ways to reduce the numbers. AZDPS is also using the data to better manage its resources on the roads. For example, AZDPS was able to significantly reduce recurring crashes in one location by strategically placing officers near the site. By knowing where and when incidents tend to occur (as well as the type of incidents), AZDPS staged its resources to reduce response times (drive times, time to deploy tow trucks). AZDPS started this program to get the supervisors involved in using the performance data and understanding how they could influence the patrol patterns of their officers [7].

The Open Roads Partnership agreement among NDOT, NHP, Clark County, the City of Las Vegas, Las Vegas Metro, and RTC lays out the goal of clearing the roadway of minor, injury, and serious/fatal incidents within 30, 60, and 90 minutes, respectively [12]. FAST has a number of strong champions who understand the importance of having data ready to use and making use of the data to “tell the story” and to strive for improvements. The data from FAST’s database and dashboard system have already been used to compare congestion from year to year. The City of Las Vegas continues to experience increases in traffic volumes, which impact congestion and reliability, particularly during traffic incidents. FAST’s dashboard and powerful back-end incident database have greatly enhanced how FAST describes and reports on congestion in and around Las Vegas. Using its system, FAST is blending congestion and incident data to determine how an effective TIM program contributes to maintaining system reliability, particularly under increasing traffic volumes [7].

#### 2.2.5. Communications and Coordination

Many agencies have found regular – either local or regional – TIM meetings to be opportune venues to engage their partners in discussions about TIM performance measurement. If performance measurement is a new topic in the agency, discussions surrounding the importance of safe, quick clearance can open the door to more in-depth discussions about measuring and tracking the performance of TIM activities. States that have strong TIM coalitions tend to have better inter-agency communications and coordination. While the establishment of a strong TIM coalition does not guarantee that a statewide TIM performance measurement program will immediately follow, it can help promote the discussion in a more coordinated manner. Each agency involved is responsible for their own performance. As a result, stakeholder groups often have different goals or objectives, and sometimes these goals and objectives do not align. Working to develop a shared understanding of everyone’s performance measures and priorities can lead to the development of common measures and goals – ones that are equally important to all agencies involved [7].

Regarding secondary crashes, TDOT and THP originally had different approaches/definitions of a secondary crash. After TDOT shared its secondary crash definition (which is consistent with FHWA’s definition) with the THP, the THP modified its definition to match that of TDOT. Everyone was trained on the definition during the TIM training, and the TITAN client now has the required feature of collecting secondary crash information [7].

---

Wisconsin's Traffic Incident Management Enhancement (TIME) program is a multi-agency program dedicated to coordinating TIM through relationships and technology. TIME has direct participation from law enforcement, fire, emergency management, towing and recovery, and transportation agencies. In 2006, the regional program was expanded to a statewide program. As a way to engage the sheriff and state patrol in discussions about incident clearance, WisDOT requires an after-action review for all incidents that close any interstate for two hours in one direction or 30 minutes in both directions [7].

VDOT is in the process of expanding and standardizing its TIM performance measurement program statewide, and this effort has involved networking and collaborating with a wide range of stakeholders, working at the executive level within VDOT, and reestablishing the statewide TIM Executive Leadership Team. This team includes a Virginia State Police (VSP) colonel and the commissioner of VDOT and meets twice a year to discuss the needs of the various TIM stakeholders and partners [7].

In 2010, it became apparent to AZDPS that it needed to both improve TIM and start collecting performance measures to determine if what the agency was doing was effective. As a result, AZDPS led the creation of a multi-disciplinary TIM partnership in Arizona. The partnership includes state and local police, fire agencies, state and local transportation agencies, metropolitan planning offices, and towing companies in the Phoenix metropolitan region. The main goal of this coalition is to share ideas, lessons learned, best practices and knowledge that fosters regional incident management [13]. AZDPS also built a coalition with ADOT to collect data. Building on a 30-year old agreement and an existing statute to share the crash data, the crash data are now sent electronically from TraCS to ADOT, increasing the availability of the data from about 8-months to about 8 days [7].

Nevada has established, well-attended TIM Coalition meetings in both its Northern region and its Southern region. The Northern and Southern TIM Coalitions meet every two months to discuss strategies, policies, and a wide range of TIM activities with stakeholders. The communication and coordination is very good among the agencies involved in these TIM coalitions [7].

### 2.3. Summary of Gaps

The following provides a brief summary of the gaps that were identified between the TIM performance measurement and reporting practices in Nevada and those of other leading peer agencies:

- There is currently no sharing or integration of data for TIM performance measurement in Nevada. Although FAST is co-located with NHP (and NDOT) in the FAST TMC, they do not integrate the NHP CAD data with FAST's dashboard system. FAST does monitor a NHP website that posts active incidents; however, this website only provides basic information. From a law enforcement perspective, NHP does not collect any specific data for TIM performance measurement.
- Outside of FAST's database and dashboard system that covers the Las Vegas area, NDOT lacks the systems and data to support comprehensive TIM performance analysis.
- Although FAST is doing well in Las Vegas with blending congestion and incident data to determine how an effective TIM program contributes to maintaining system reliability, there is little use of TIM performance analysis to support performance management and decision-making in Nevada.
- Overall communications and coordination is strong in Nevada, particularly with the TIM coalitions in Las Vegas and Reno. However, there have been few discussions centered on measuring and reporting TIM performance or the importance thereof.

- 
- The FAST dashboard interface allows operators to capture secondary crashes; however, there may be room for improvement from revisiting the process used to identify secondary crashes to ensure that accurate and credible data are collected. The resulting data can be inconsistent.
  - Typically, at FAST, once an incident is cleared from the roadway, it is no longer tracked. FAST's challenges with collecting ICT are primarily related to staffing resources. It was reported that increased coordination with NHP and other responders would be necessary to begin collecting and reporting incident clearance times from field personnel.

The findings from this research project and the resulting recommendations should help close these gaps and help to advance Nevada's TIM program to the next level.

---

## 3. ASSESSMENT OF THE QUALITY AND QUANTITY OF INCIDENT DATA

The second objective of this research project was to assess the quality and quantity of the data available in Nevada for TIM performance analysis. To accomplish this objective, various datasets were compared against the data elements required to calculate the three national TIM performance measures and against the data elements needed to populate the NCHRP 07-20 TIM performance measures data model. The following sections provide an overview of the approach, as well as a summary of the findings.

### 3.1. Overview of Approach

The approach to assessing the data available for TIM performance analysis in Nevada was to gather incident data from a variety of sources and to then “map” the data elements in these data sources to those in the data model developed as part of NCHRP Project 07-20. In an attempt to assess data from a variety of responders and locations across the state, data were obtained from the following five sources and associated time periods:

- FAST – all incidents between the last quarter of 2009 and the first quarter of 2015
- NDOT’s NNROC – “significant” incidents only from January 2014 to June 2015
- NDOT’s FSP programs in Las Vegas and Reno – incidents between October 2013 and April 2015
- NDOT crash database – crashes from January 2013 to February 2015
- NHP CAD system – crashes from 2013 and 2014

In addition to these data sources, the research team attempted to obtain data from the Clark County Fire Department CAD system and the Las Vegas Metropolitan Police Department CAD system. While a cursory assessment of the data elements in these databases was made, for various reasons, the team was unable to secure sample datasets. As such, no data were available for a more detailed assessment.

As a basis for conducting an analysis on the quality of the five incident data sources, the research team made use of a TIM performance measures checklist developed as part of the FHWA effort towards the national institutionalization of TIM performance measures [7]. This checklist includes all of the data elements in the NCHRP 07-20 data model, including the data elements required to calculate the three national TIM performance measures, data elements needed to calculate other time-based TIM performance measures, and additional data elements desirable for conducting more disaggregate and meaningful TIM performance analyses [2].

The original data checklist is shown in Appendix C. For this research project, the checklist was tailored to the Nevada datasets and divided into two separate checklists – one for the “required” data elements for the national TIM performance measures and one for the “desired” data elements in the NCHRP data model. This modification allowed the research team to conduct two separate assessments of the data to meet the objectives of the data assessment.

### 3.2. Summary of Findings

This section of the report describes the findings of the data assessment. The findings are discussed separately for required data elements and the desired data elements.

### 3.2.1. Required Data Elements for TIM Performance Analyses

As previously discussed, there are four data elements required to calculate the three national TIM performance measures. Table 4 summarizes the findings from the assessment of the five Nevada incident data sources against these required data elements. The assessment of the data associated with each of the four required data elements is discussed in more detail in the following sections.

Table 4. Availability of Required Data Elements

Required Data Elements for Three National TIM Performance Measures	Data Sources				
	Transportation			Public Safety	
	FAST (Las Vegas)	NNROC (Reno)	FSP	NDOT Crash Database	NHP CAD
Time of first recordable awareness of an incident by a responsible agency		√ <sup>1</sup>	√ <sup>1</sup>	√ <sup>1</sup>	√ <sup>1</sup>
Time of first confirmation that all lanes are available for traffic flow	√	√ <sup>2</sup>			√ <sup>3</sup>
Time last responder has left scene			√ <sup>4</sup>		√ <sup>4</sup>
Whether a crash is secondary to a primary crash/incident	√	√			

<sup>1</sup>Specific to each agency’s awareness (no common/overall time stamp/“first awareness” of incident). For FSP this can be the time of call (from NHP), time of dispatch from the TMC, or time that an FSP operator comes upon an incident while on patrol. The most consistent with FHWA’s definition would be the time of call from NHP in the CAD system.

<sup>2</sup>“Recorded as “duration of blockage,” which is recorded for significant incidents” only. While not usable as is in the data model, combined with incident reported time, could back into this time stamp.

<sup>3</sup>Recorded as “all travel lanes open” for *some* incidents in the dataset.

<sup>4</sup>Specific to that agency’s responders leaving the scene. For NHP, need to note the *last* responder that left the scene.

#### 3.2.1.1. Time of First Recordable Awareness of an Incident by a Responsible Agency

The time of first recordable awareness of an incident by a responsible agency establishes the “start” time of an incident, from which RCT and ICT are calculated. The intent of this definition is to establish the *earliest time* of awareness by any responsible agency, not just the transportation agency.

In the assessment of the Nevada data sources, every source has an incident date and time that is specific to the agency/organization collecting the data, which may or may not be the agency’s first awareness. For example, for FAST, the “incident time” stamp occurs when FAST enters the incident into its system, and this is not usually FAST’s first awareness of the incident. In fact, incidents are generally not entered into the system until after they are verified by positioning the cameras and after variable message signs (VMS) have been updated with incident information. This is not consistent with FHWA’s definitions for RCT and ICT. For the NDOT crash data, there is only one-time stamp associated with each crash report – “crash date” and “crash time” – and this time is associated with the “date reported” (date and time) in the NHP CAD system. This time is assumed to be the first awareness of the incident by a responsible agency.



---

The incident times are not generally shared across agencies or datasets; therefore, in order to determine the “first recordable awareness of an incident by a responsible agency,” these times would need to be compared and the earliest time identified. Alternatively, the partners might conclude that the CAD data offer the earliest awareness of incidents, but these data need to be processed and shared with NDOT in a usable format.

#### *3.2.1.2. Time of First Confirmation that All Lanes Are Available for Traffic Flow*

The time of first confirmation that all lanes are available for traffic flow allows for the RCT performance measure to be calculated. FAST records this time as “lane cleared,” which is obtained through operators monitoring CCTV cameras and through communications with field personnel. NDOT’s NNROC operations center records when there is a “road/lane blocked” and the “duration of blockage,” rather than recording the time at which the blockage was removed, and these data are recorded for significant incidents only (it is also assumed that the “duration of blockage” is an estimate of the blockage as opposed to a measured value). There is a status code in the NHP CAD data that has a timestamp called “all travel lanes open,” but these data would need to be processed and shared with NDOT in a usable format to be useful for NDOT for TIM performance analyses.

If the datasets are kept separate (or as is), RCT can be calculated only for incidents in Las Vegas in the FAST database (and this value is based on the start time as recorded by FAST, which is not the “first recordable awareness by a responsible agency”). However, if NDOT could augment the crash database with additional NHP CAD data elements, RCT could be calculated statewide for every incident involving an NHP officer (assuming the roadway clearance time is recorded). This approach would increase NDOT’s ability to report TIM performance (at least in terms of RCT) many times over.

#### *3.2.1.3. Time Last Responder Has Left the Scene*

The time the last responder has left the scene allows for the ICT performance measure to be calculated. FAST and NDOT’s NNROC do not currently note this time, nor is this time found in the NDOT crash database. The time that the NHP officer(s) leaves the scene can be found in CAD; however, often times there is more than one NHP officer on scene, and all of these times can be found in the CAD data. Further, these departure times are not necessarily the times the last responder left the scene (e.g., towing might still be on the scene after the NHP officer(s) departs). At this point, then, the NHP and/or fire CAD systems are the only way in which Nevada can report ICT. If these data can be leveraged, then ICT could be calculated for every incident statewide involving an NHP officer (assuming this time is recorded).

#### *3.2.1.4. Secondary Crashes*

The FAST interface allows operators to capture secondary crashes through use of a “secondary” check box; however, FAST reports that this check box is not consistently used. NDOT’s NNROC also records secondary crashes. FAST and NNROC are the only source of secondary crashes in Nevada.

### *3.2.2. Desired Data Elements for TIM Performance Analyses*

Beyond the four data elements required to calculate the three national TIM performance measures, there are 36 data elements in the NCHRP 07-20 data model. Table 5 summarizes the findings from the assessment of the five Nevada incident data sources against these desired data elements. A general discussion of the assessment of these data follows the table.

Table 5. Availability of Desired Data Elements

Desired Data Elements in the NCHRP 07-20 Data Model	Data Sources				
	Transportation			Transportation	
	FAST (Las Vegas)	NNROC (Reno)	FSP	NDOT Crash Database	NHP CAD
Time incident verified					
Time response identified					
Time response dispatched		√ <sup>2</sup>	√ <sup>3</sup>		√
Time first response arrives on scene	√ <sup>1</sup>	√ <sup>2</sup>	√ <sup>4</sup>		√
Time normal traffic flow returns					
Date of Incident	√	√	√	√	√
Time incident occurred					
Description of Incident	√	√	√	√ <sup>5</sup>	√ <sup>6</sup>
Incident type	√		√	√	
Severity of incident	√				
Severity of injury	√	√ <sup>7</sup>		√	
Weather conditions				√	
Lighting conditions				√	
Roadway name	√	√	√	√	
Roadway type	√				
Roadway direction	√		√	√	
Roadway location	√	√ <sup>8</sup>	√ <sup>9</sup>	√ <sup>10</sup>	
Surface condition				√	
Work zone		√			
Number of lanes involved	√	√			
Total roadway lanes at scene					
Time of closing/opening of each lane involved					
Number of vehicles involved				√ <sup>11</sup>	
Hazmat vehicle					√ <sup>12</sup>
Heavy vehicle involved	√				
Number of participants involved					
Injury involved	√ <sup>13</sup>				
Number of Injuries				√ <sup>14</sup>	
Injury type				√	
Participant types					
Number of responders involved					√
Response organization					√
Responder(s) ID					√
Response vehicle(s) type	√ <sup>15</sup>		√ <sup>16</sup>		√
Response vehicle(s) arrival on scene					√
Response vehicle(s) departure from scene					√

<sup>1</sup> For tow trucks only.

<sup>2</sup> Specific to NDOT responders and for significant incidents only.

<sup>3</sup> Only when call from NHP is made for an FSP vehicle.

<sup>4</sup> Only entered for some incidents. Specific to FSP responders.

<sup>5</sup> No specific description field but two columns that describe the behavior of the vehicles involved.

<sup>6</sup> "Status notes" sometimes contain minimal and unstructured updates about activities at the incident scene.

<sup>7</sup> Coded. Code appears to combine injury type codes with number of injuries. Could possibly be parsed into minor, major, and fatalities and numbers of each.

<sup>8</sup> One “location” field that contains free text description of location following a cross-street location format (e.g., I-80 at Wells). Difficult to parse to get actual location.

<sup>9</sup> Roadway location represented by two columns: “along” and “at;” “at” value is mostly blank; therefore, location primarily roadway name.

<sup>10</sup> Cross-street and latitude/longitude (processed by NDOT).

<sup>11</sup> Up to 2 vehicles only.

<sup>12</sup> 10-codes show codes for hazmat, but this was not included in the data received from NHP.

<sup>13</sup> Injury known only by checked “ambulance” box (injury or no injury).

<sup>14</sup> Not directly but could be derived from injury type code and crash severity field.

<sup>15</sup> Only for tow truck and ambulance.

<sup>16</sup> FSP vehicle on scene only.

While having all of the data elements in Table 5 is by no means mandatory, the more of these data elements that are available, the more that can be used to conduct detailed TIM performance analyses. The most common data elements used by agencies to break down the reporting of the TIM performance measures include: incident severity, injury severity, and roadway name. FAST could report TIM performance by all these factors in some fashion for the incidents in its dashboard system. FAST records incident severity by noting one of four levels of severity, including: “N/A,” “negligible,” “noticeable,” “severe,” and “significant.” FAST also records injury incidents through the “injury/ambulance” check box, which would allow for performance to be measured for injuries versus no injuries. FAST could also report TIM performance for the various roadways within its coverage area based on location (such as roadway name).

### 3.2.3. General Analysis of Incident Data Available in Nevada

From Table 4 and Table 5 it is clear, particularly on a statewide level, that the NHP CAD data combined with the crash data provide the most comprehensive source of incident data for analyzing TIM performance, but these datasets need to be merged and leveraged for this purpose. Figure 3 is a graphical representation of the incident databases that were assessed for this project.<sup>1</sup> The grey oval represents the NHP CAD data associated with all types of traffic incidents. A subset of these incidents are crashes, which are represented by the blue oval. These crashes have associated crash reports that are completed by NHP officers, processed by NHP, and provided in a database to NDOT for further processing in the NDOT crash database. Therefore, all of the NHP data shown outside of the blue oval, but inside the grey oval, are non-crash incidents, for which the research team did not have data. The green oval represents the incidents in which the NDOT FSP is involved in both Las Vegas and Reno – some crash and some non-crash. Finally, the orange oval represents the incidents (crash and non-crash) that occur within FAST’s coverage area, primarily the Las Vegas urban freeway/highway network and some major arterial streets. Some of these incidents involve NHP, FSP, or both.

---

<sup>1</sup> It is recognized that there may be other response agencies involved (and thus additional databases), including local law enforcement and fire, emergency medical services (EMS), towing, coroner’s office, and hazardous materials teams; however, obtaining and assessing data from all possible incident response organizations was outside the scope of this research study.

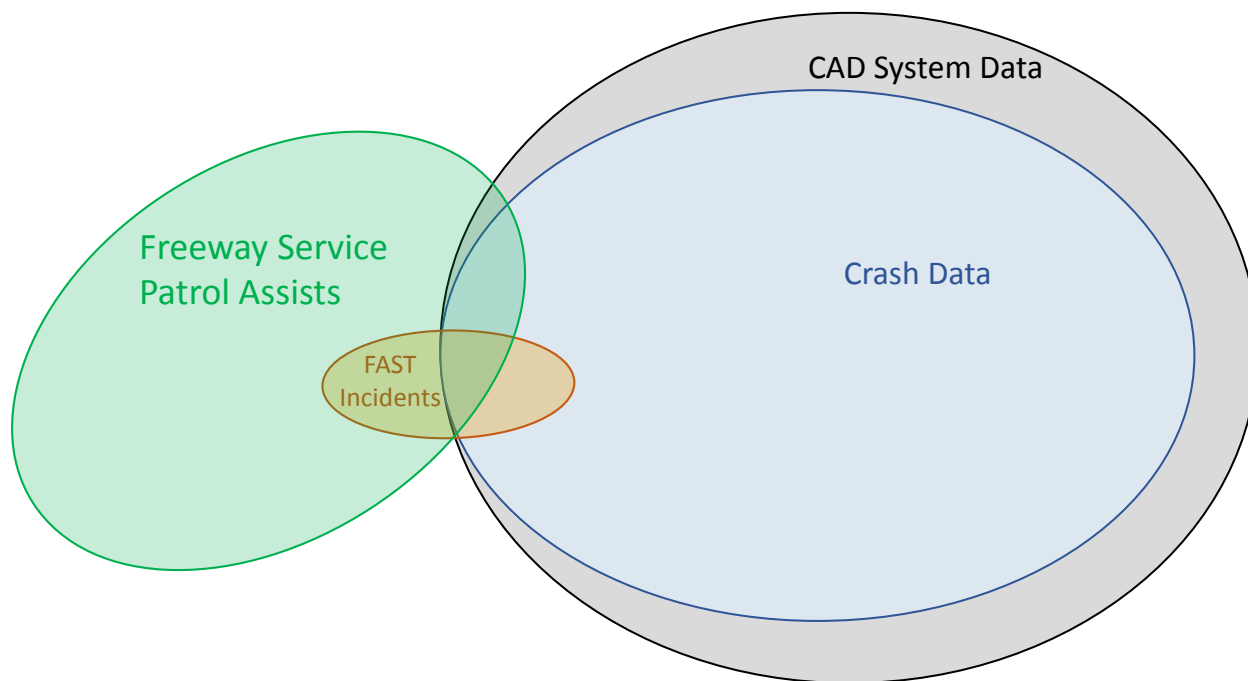

*Figure 3. Incident Datasets Assessed*

Figure 3 illustrates two important points: the magnitude of the incident data overall and the overlap in data between the agencies. While the graphic is not necessarily to scale, it is meant to be at least somewhat representative of the magnitude of incidents in which the various organizations are involved and how these might overlap. It shows that law enforcement (CAD) is involved in the most incidents statewide.

However, considering the data elements in each of the datasets (as assessed in Table 4 and Table 5), simply having data for the most incidents is not necessarily the best. For example, there are more crash reports than in any of the other databases, and the crash data contain several descriptive data elements not found in the other datasets (e.g., weather and lighting conditions); however, the crash database does not include time stamps to calculate roadway or incident clearance times, nor does it include secondary crashes. Therefore, none of the three national TIM performance measures can be calculated using the crash data alone. Similarly, the FSP assist database contains a large number of assists, but it lacks adequate location details. On the other hand, the FAST database contains location details, the time at which the roadway is cleared, and secondary crashes, but lacks a comparative magnitude of incidents to FSP and NDOT. The NHP CAD data – also statewide – provide many of the critical time stamps (e.g., time of first awareness, time incident verified, time of arrival on scene, time roadway lanes cleared, time incident cleared (when NHP was last to depart the scene)) as well as other data elements that can be used in performance analyses, but is not directly accessible by NDOT for performance analyses.

It is clear that in order for NDOT and the Nevada TIM partners to evaluate TIM performance on a statewide basis, that integration of the various databases is necessary. This data integration is presented in the following chapter.

## 4. DEVELOPMENT OF A PROTOTYPE TIM PERFORMANCE MEASUREMENT DATABASE

The third objective of this project was to create a prototype TIM performance measurement database that contains consistent incident data from various sources across the state. This chapter describes the process that was undertaken to meet this objective, as well as the challenges and findings.

### 4.1. Data Integration

As was presented and described in Chapter 3, none of the data sources assessed contained all of the required and desired data elements necessary for a robust TIM performance analysis. Therefore, to meet the third objective, it was necessary to integrate the incident data from the various data sources into a single database to allow for the calculation of the TIM performance measures. The data integration was a multi-step process, which is depicted in Figure 4. In the diagram, each step is labeled, with “TIM DB” representing the TIM database that was built by integrating the various datasets as shown. This process is described in more detail following the figure.

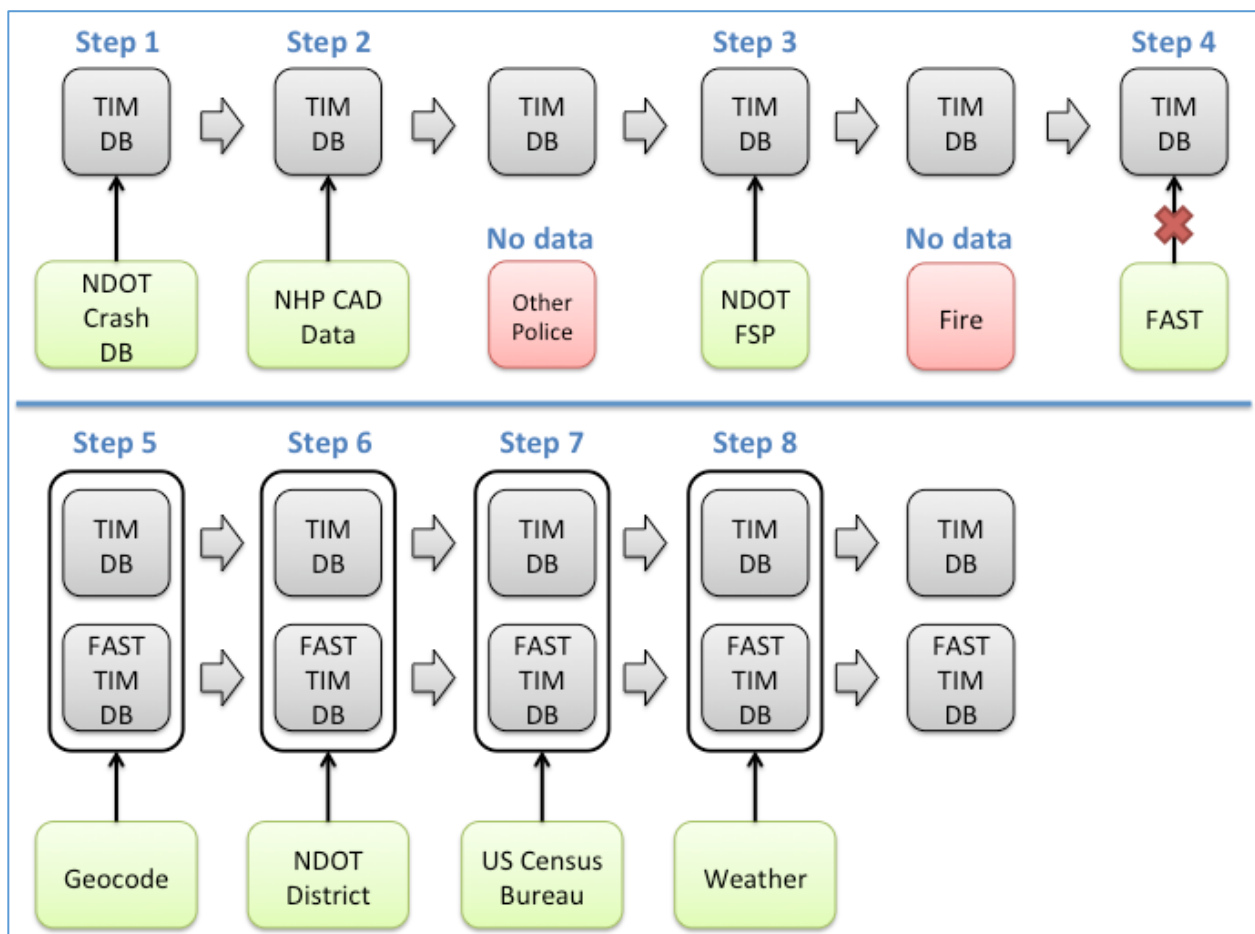

Figure 4. Data Integration Process

---

### Step 1 – MAP NDOT Crash Data to NCHRP 07-20 Data Model to Create Base Dataset

The NDOT crash database was used as the base dataset from which to start the data integration process. The data elements in this dataset were first mapped to the NCHRP 07-20 data model to standardize the data. This dataset provided many of the desired data elements, including crash location (in terms of latitude and longitude), incident type, severity of injury, weather conditions, and lighting conditions. The availability of these data elements is important for more detailed/refined analyses of TIM performance. The time stamps for calculating the TIM performance measures, however, were not available in the NDOT crash database, but data elements such as call number and responding agency name were present for each incident. The NDOT crash database call number data element came from the responding law enforcement agencies' CAD logs, which also contained timestamps. Therefore, the next step involved augmenting the NDOT crash database with data from the CAD system, in this case the NHP CAD system.

### Step 2 – Merge NHP CAD Data with NDOT Crash Data

To accomplish this step, the NHP "10-codes" present in the CAD data were first reviewed and mapped to the NCHRP 07-20 data model to standardize the CAD data, and then the timestamps for each NHP 10-code of interest (such as 10-23, "arrived on scene," or 10-82, "all travel lanes open") were extracted and transposed for each call number. The resulting table was then joined with the NDOT crash data using the call numbers associated with the crashes. While the exact time stamps needed to calculate the TIM performance measures were not necessarily available in the NHP CAD data, this step provided time stamped data elements that were used to infer the performance time stamps

To calculate RTs, RCTs, and ICTs (for crashes involving an NHP officer) the following time stamps were needed: the "time of first awareness" of crashes involving an NHP officer, the time the first NHP officer arrived, the time the roadway lanes were opened, and the time the last NHP officer left the scene. The "date reported" CAD data element was used as the "time of first awareness," and the earliest occurrence of a "10-23 arrived on scene" event was used as the time the first NHP officer arrived on the scene. The time the last NHP officer left the scene was more difficult to obtain, as the last occurrence of a 10-24, "completed call" event is often the last step of the crash investigation and can occur several hours or even days after the crash happened. It was observed, however, that the "10-24 completed call" events logged during an incident response were close in time at the beginning of the incident and then occurred less frequently. Therefore, for each incident, the last "10-24 completed call" event without a long time gap before a new "10-23 arrived on scene" event was identified and used as the time the last NHP officer left the scene. The time the travel lanes were reopened was identified using the "10-82 all travel lanes open" event timestamp in the NHP CAD logs.

### Step 3 – Add FSP Data to NDOT/NHP Data

Using the "incident data, "dispatch time," "arrival time," "departure time," "along," "traveling," and "mitigation type" data elements in the FSP datasets, the non-crash incidents (e.g., debris on road, disabled vehicle, other) were identified and mapped to the NCHRP 07-20 data model to standardize the data. These incidents were then added to the combined NDOT-CAD dataset. This step provided the incident time, arrival of FSP vehicle, departure of FSP vehicle (clearance time), and some limited details

---

(such as roadway name, assist type, and description of incident) for the non-crash incidents/assists handled by FSP.<sup>2</sup>

#### Step 4 – Add FAST Data

Next, the incident data from FAST were mapped to the NCHRP 07-20 data model to standardize the data. The FAST incident data contain both crash and non-crash events for the Las Vegas area and theoretically would complete and augment the NDOT-CAD-FSP dataset by adding incident not involving NHP and data elements such as “lanes involved,” “tow truck arrival time,” “secondary incident” flag, “hazmat” flag, and “heavy vehicle involved” flag that were not present in the NDOT-CAD-FSP dataset. Unfortunately, the FAST incident data did not contain any data elements referencing an NHP or FSP call or incident number. Therefore, joining the FAST incident data with the NDOT-CAD-FSP dataset using a common call or incident number was not possible, and adding the FAST incident data directly to the database would have duplicated incidents already present in the NDOT-CAD-FSP dataset.

An attempt was made to join the FAST incident data with the combined NDOT-CAD-FSP dataset using a combination of a GIS spatial-temporal join to identify incidents in both datasets that occurred at the same location and within a minute of each other. A manual review was conducted of each match to identify incidents that were the same. However, this attempt was not successful in matching enough records to be significant for TIM performance analyses. Differences in time and location precision between the two datasets led to a majority of false positive matches – incidents that were a close match in location and time but with different incident descriptions. Therefore, it was decided to keep the FAST incident data in a separate but NCHRP 07-20-compliant database. In other words, TIM performance analyses can be conducted on the data, but only on the FAST data alone.

#### Step 5 – Standardize Incident Locations

The next step was to standardize the location data elements. Some of the NCHRP 07-20 location data elements (e.g., roadway name) were present in the NDOT-CAD-FSP dataset, but some were problematic due to spelling differences or multiple was of referencing the same location. For example, the McCarran Airport connector was referred to as “airport connector,” “SR171,” or even “connector”. These reporting inconsistencies are troublesome when building a dashboard geographic filtering feature, as each location name/spelling would be considered a different roadway when in fact they are the same. To remedy these issues without correcting each and every inconsistency or error, the location data elements were standardized in the NDOT-CAD-FSP dataset. For incidents with known latitudes and longitudes, and online geocoding service was used to reverse-geocode each incident’s coordinates into a consistent “roadway name,” “city name,” “county name,” “zip code,” and, in some cases, “street” and “number.” This process provided, for geo-referenced incidents, standardized names for each of these data elements that would allow for a geographical hierarchy that could be used to filter the TIM performance analyses.

---

<sup>2</sup> The FSP assists involving crashes were not joined with the NDOT-CAD dataset because the FSP location information was not accurate enough to identify matches (if matches were not identified, then incidents would be double counted).

---

## Step 6 – Identify NDOT District and Sub-District for Incidents

Ideally for NDOT, TIM performance analyses could be aggregated for each NDOT district and sub-district; however, none of the data sources assessed provided the NDOT district or sub-district in which the incidents occurred. Therefore, this information needed to be inferred from the incidents' latitudes and longitudes. To accomplish this, a geospatial database was used to perform a spatial join between the NDOT-CAD-FSP dataset and a GIS dataset (ESRI shapefile) representing the geography of NDOT's districts and sub-districts. This process mapped each geo-referenced incident to a district name, district code, sub-district name, and sub-district code. For the non-geo-referenced data such as the FSP data, this process was conducted by using the location data element with the lowest resolution, in most case the city (Reno or Las Vegas) to derive the district name and code.

## Step 7 – Identify Rural vs. Urban Incidents

Similar to NDOT districts and sub-districts, analyzing TIM performance for urban versus rural incidents could be of interest to NDOT and its TIM partners, as performance measures such as response time can vary widely between incident occurring in rural and urban areas. In order to identify which incidents in the NDOT-CAD-FSP dataset occurred in rural areas and which incidents occurred in urban areas, a geospatial database, was used to perform a spatial join between the NDOT-CAD-FSP dataset and a GIS dataset (ESRI shapefile) from the US Census Common Core Data representing the CONUS official urban areas as of 2014. This process was done to map each geo-referenced incident to a rural or urban area. For the non-geo-referenced data such as the FSP data, this process was not conducted.

## Step 8 – Merge Weather Data

Similar to the geographic location discussed in Steps 6 and 7, the databases contained some data elements relating to the weather conditions at the time of the incidents; however, this information was limited and not standardized across the databases and incidents (e.g., some weather information was in free-form text and some following an emergency response standard). Even using standards to report on weather conditions, a few keywords limit the description of weather to two or more weather conditions, for example heavy precipitation and high wind, which can occur at the same time. Rather than relying on user-entered data, an online historical weather database, Forecast.io, was leveraged. Forecast.io provides a much more complete view of weather as compared to the weather choices in any of the databases or the NCHRP data model, including historical weather conditions, detailed daily and current weather conditions (e.g., wind, visibility, precipitation, temperature) at a minute interval and square mile resolution. Knowing the precise time (first awareness timestamp) and location (latitude and longitude) of incidents, this database was used to infer detailed and standardized weather conditions at the time of each incident. As such, weather data for each of the geo-referenced incident in the NDOT-CAD-FSP dataset were pulled directly from the Forecast.io web API using the times and locations of the incidents. This step allows the TIM performance measures to be aggregated and analyzed by various weather conditions.



## 4.2. Results

The process of integrating the various datasets was successful in that data elements from the different sources were merged to allow for analyses that could not have been conducted without the data being integrated. However, due to a number of challenges and limitations associated with the available data, the amount of usable data for TIM performance analyses, particularly considering the amount of data provided by NDOT and its TIM partners for this research project, was rather small. The results, in terms of usable data in terms of TIM performance analysis, are illustrated in Figure 5 and discussed below.

At the top of the data “funnel” is the overall number of incidents available from the samples provided from the NDOT crash database and the NDOT FSP assist database prior to integrating the data. These 133,614 incidents represent crash and non-crash incidents for a two-year period across the state of Nevada. To provide a sense of how these incidents were distributed across the state, of the 133,614 incidents:

- 34,210 (25%) were crashes that involved an NHP officer (statewide)
- 38,084 (29%) were crashes that involved an LVMPD officer (Las Vegas area)
- 42,455 (32%) were assists by the Las Vegas FSP (Las Vegas area)
- 8,355 (6%) were assists by the Reno FSP (Reno area)
- The remaining 10,510 (8%) of the incidents involved municipal police departments throughout the state (statewide).

It should be noted that 4,601 incidents were provided during the same time period from FAST; however, as these incidents could not be linked to the incidents in the crash or FSP datasets, they were kept separate to avoid double counting incidents.

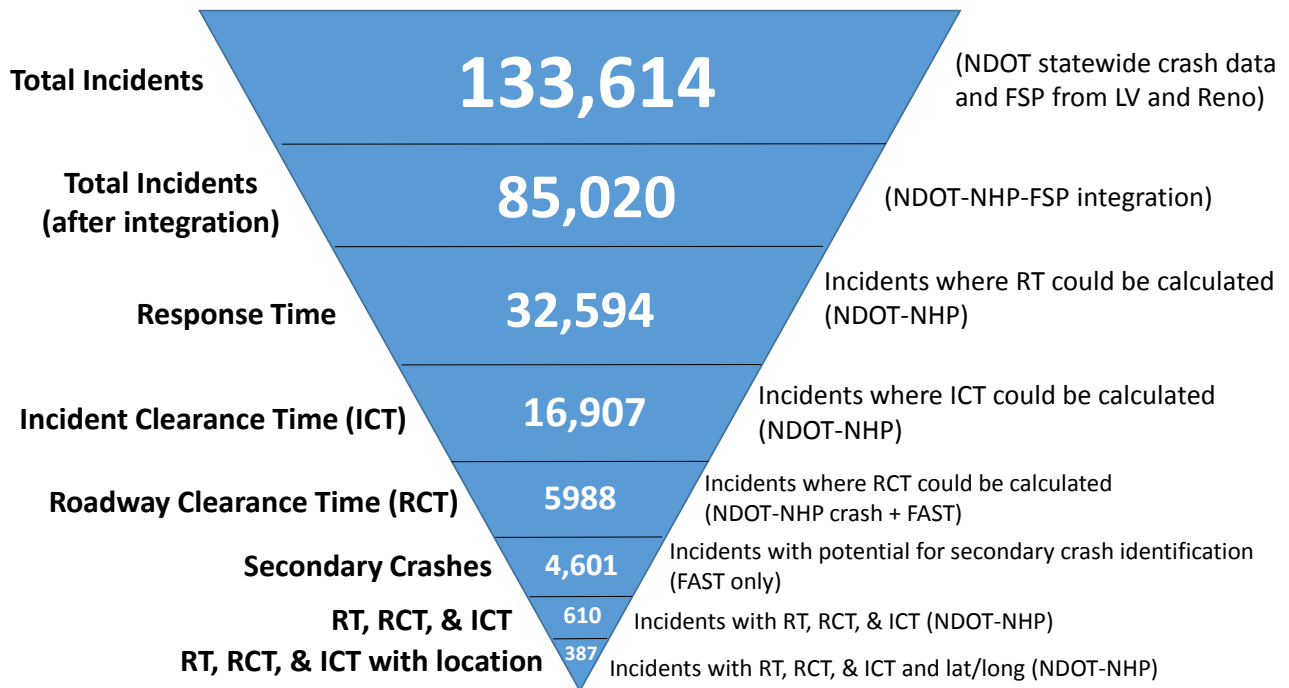

Figure 5. Nevada TIM Performance Analysis Data “Funnel”

---

Once the data integration process began, the crashes involving any of the municipal police departments (including Las Vegas) dropped out because there were no CAD data available from these police departments with which to integrate with the NDOT crash data. While the research team attempted to obtain LVMPD CAD data through NDOT, the data were not made available, and obtaining CAD data from the other 26 police departments throughout the state was outside of the scope of this pilot study.

Therefore, in the first three steps of the data integration process (merging NHP CAD data, NDOT crash data, and FSP data), there were a total of 85,020 incidents on which TIM performance analysis could potentially be conducted.

From these 85,020 incidents, the database was queried to determine for how many of these incidents an RT could be calculated. From the NDOT-NHP incidents, 32,594 (38%) had the data elements to calculate an RT. It should be noted that the 50,810 FSP incidents were excluded due to the lack of a time stamp representing the “first awareness of the incident by a responsible agency” or even a “time of dispatch” from which to calculate RT. While in some (if not many) cases, the RT may have in fact been zero – when an FSP patrol happens upon an incident – there was a large majority of incidents in the FSP dataset with no dispatch time. Without a more accurate reporting and recording of how and when the FSP becomes aware of incidents, any calculation of RT, RCT, or ICT would likely be misleading.

Similarly, the 85,020 incidents were queried to determine for how many of these incidents an ICT could be calculated. From the NDOT-NHP incidents, 16,907 (20%) had the data elements to calculate ICT. A form of incident clearance time could be calculated for the FSP data – using the incident clearance time and the arrival time (or dispatch time, when available); however, this calculation is not consistent with the FHWA definition of ICT, which starts from the first awareness of an incident by a responsible agency. Again, better recording of the incident timeline by the FSP would facilitate the calculation of the performance measures for the FSP assists.

For calculating RCT, only 1,387 (<2%) of the 85,020 incidents had the required data elements. Including the 4,601 incidents from FAST increases that number to at most 5,988, assuming no duplication of incidents between the two datasets. It should be noted that it is not known from the FSP database if or when a roadway lane is blocked/cleared.

Regarding secondary crashes, FAST is the only incident data source in the state of Nevada from which secondary crashes can be identified, giving a maximum potential of 4,601 incidents from which to identify potential secondary crashes, and this is limited to the Las Vegas area (not statewide).

Finally, there were only 610 crashes out of the 85,020 NDOT-NHP crashes for which an RT, RCT, and ICT could be calculated, and of these only 387 of them could be geo-located using the data.

Once again, the process of integrating the data was successful, but telling, in terms of the quantity of data available to NDOT and the Nevada TIM partners for TIM performance analysis. The results did show the ability to calculate RT on a little more than one-third of the NDOT-NHP integrated crashes, ICT on 20 percent of the NDOT-NHP integrated crashes, and RCT for about 2 percent of the NDOT-NHP crashes. While calculating RT and ICT for the FSP data is possible, the way in which the incident timeline is recorded is not necessarily consistent with the FHWA definitions and may lead to misleading results.

The biggest barrier for NDOT in calculating the TIM performance measures on a statewide basis is that incident data are not always collected with the TIM performance measures in mind (specifically for the purpose of TIM performance analyses). Therefore, the required and desired data elements are not readily available in the databases for TIM performance analyses. Making a concerted effort towards

---

collecting these data elements through the crash form, via the responding agencies' CAD systems, and by the FSP will greatly improve NDOT's ability to assess and report on TIM performance statewide. Other recommendations for improving the data are discussed in Chapter 6.

### 4.3. Challenges

There were a number of challenges experienced during the data integration process. These challenges are briefly summarized below in terms of the specific databases and data elements.

- Nevada DOT Crash Database – The NDOT crash database, while including many of the fields required to categorize and aggregate TIM performance measure (e.g., location, weather conditions, roadway surface conditions, roadway name, and participants count), the database did not include a geo-referenced location (a.k.a. latitude and longitude) for many of its records. Only about 60 percent of the NDOT crash database records were geo-coded. Some of the largest crash record providers, such as NHP and the LVMPD, were between 55 and 65 percent geo-referenced. Other crash records sources, such as the University of Nevada Las Vegas Police Department (UNLVPD) and the University of Nevada Reno Police Department (UNRPD), were not geo-referenced at all.
- NHP CAD Data – The NHP CAD data provided included a large table containing a time series of crash events where each event contained a call number, an incident number, and a description of what happened during the NHP response. This table contained the arrival and departure time of police units as well as the timestamp for NHP 10-codes of interest for TIM performance analysis such as “10-82 all travel lanes opened.” The challenge encountered with the NHP CAD data was to derive from the time series data the time of first arrival and last departure of a NHP responder. Rather than have the explicit times recorded (such as is done on the crash form in Arizona, Florida, and Tennessee), these times needed to be derived through various transpositions, aggregations, and filtering of the time series data. During this process, inconsistent timestamps were found. The timestamps of some events, such as response arrival, were not consistently timestamped for the same unit departure with the same response. One of the primary challenges with the NHP CAD data was to identify the departure of the *last* responder to leave the scene, as the “10 -24” code was used more generally for a “completed call,” which could include subsequent visits by NHP officers to the incident site several hours or even days after the incident occurred.
- Other Police Department CAD Data – CAD data from the LVMPD was requested but was not able to be obtained during this study.
- NDOT FSP Database – Detailed FSP incident logs covering about a year and a half of activity in both Las Vegas and Reno were obtained from NDOT. The FSP logs did include location, dispatch time, arrival time, departure time, and mitigation type; however, the location recorded was provided as a cross-street reference as opposed to a latitude and longitude. Cross-streets were expressed using street names that were more or less standardized, but often handwritten. FSP timestamps were sometimes inconsistent due to the nature of the FSP activities. Based on conversations with NDOT, it is thought that many dispatch times (particularly in Reno) were missing. Mitigation types for the Las Vegas FSP log data were standardized and easy to process, but the mitigation type data from Reno was not standardized and often entered as free text, which made the classification of the Reno FSP incidents difficult.

- 
- Fire Data – CAD data from the Clark County Fire Department (CCFD) was requested but was not able to be obtained during this study.
  - FAST Data – The FAST dataset was rather complete and included a geo-referenced location for each incident as well as data fields not collected by other sources (e.g., secondary crash flag, hazmat flag, heavy vehicle flag). Unfortunately, however, the FAST dataset was collected as a standalone database and did not contain any reference to a responding agency call number or incident number such as an NHP call number. This made the FAST dataset nearly impossible to merge with the rest of the data without duplicating a large amount of already ingested incidents and affecting the TIM performance measures.
  - Location Data – Incident location data were present in most data sources, however, different formats were used and often different names or spellings were found for the same roadways. This created issues when attempting to standardize locations across data sources. Rather than attempt to correct all records, an online reverse geocoding service was used to obtain standardized geographic locations from the collected latitude and longitude.
  - Weather Data – Weather information associated with the incidents was present in some data sources but was not consistently referenced (some standardized, some free text, different standards used). This created issues when attempting to standardize weather information across the data sources. Rather than attempting to correct and standardize all of the records, an online historical weather data service was used to obtain standardized weather information from the collected reported time, latitude, and longitude of the incidents.
  - NDOT Districts and Sub-Districts – None of the data sources referred to the location of the incidents with regards to the NDOT geographical boundaries (i.e., NDOT districts and sub-districts).
  - Locale Data – None of the data sources referred to the locale of the incidents (i.e., rural or urban).

While the data integration process may not be the best long term approach for obtaining the data needed to conduct statewide TIM performance analyses, it has served to demonstrate, on a limited scale, what could be done with a comprehensive database and how it could benefit the state (discussed in Chapter 5). Beyond this limited prototype TIM performance measures database, it likely will be more efficient and effective for NDOT and its TIM partners to focus on improving incident data collection in the future (see Chapter 6 for recommendations).

## 5. PROTOTYPE TIM PERFORMANCE DASHBOARD

The fourth and final objective of this research project was to build a prototype dashboard to display consistent statewide TIM performance measures, calculated by querying the TIM performance measurement database described in Chapter 4. This chapter describes the prototype dashboard.

### 5.1. Approach

The goal for the prototype Nevada TIM performance dashboard was to provide a snapshot of a wide range of performance measures, both at an aggregate level and at a more disaggregate level. The approach was to examine how other leading agencies report and visualize TIM performance, examine a variety of dashboards from other disciplines, and design a mock-up for Nevada's TIM performance measures dashboard.

#### 5.1.1. Visualization of TIM Performance

Based on the review conducted as part of the second objective, several agencies do a good job of creating useful visualizations of TIM performance. As one particularly good example, MDOT produces standardized monthly performance reports that include colorful graphics showing average aggregate RCTs and ICTs, as well as graphs that break down the number of incidents by incident severity/duration (to give further context to the average clearance times). The number and percentage of secondary crashes is also noted at the bottom of these graphs, as can be seen in Figure 6.

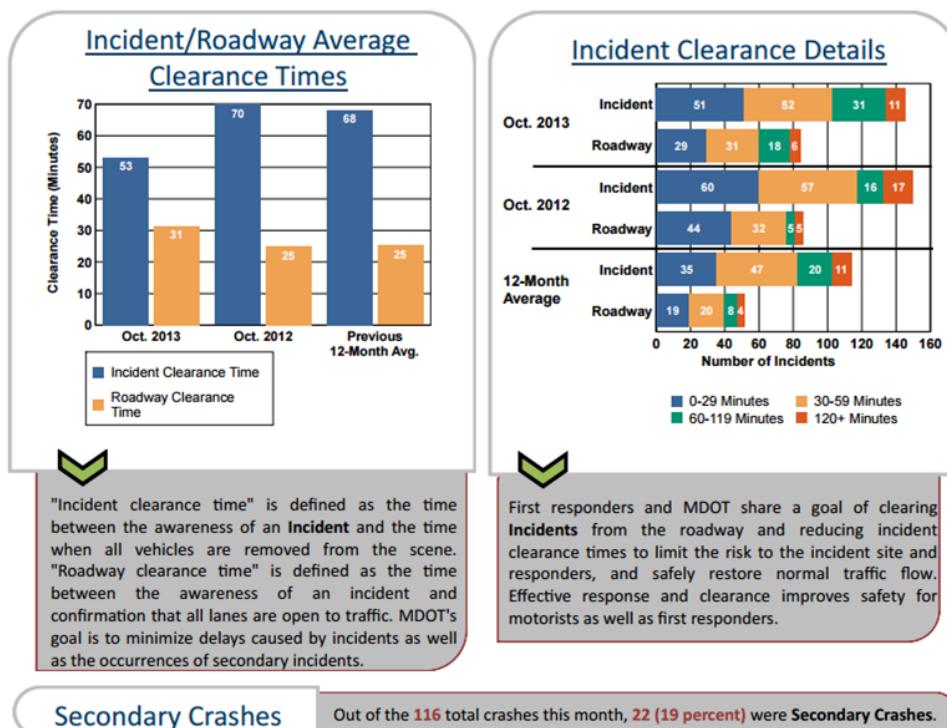

**Source:** Michigan Department of Transportation

Figure 6. Extract from West Michigan Traffic Operations Center's October 2014 Performance Measures Report

Similarly, VDOT produces quarterly reports that contain a variety of neat and colorful graphs depicting TOC and TIM performance. One interesting graph found in the Fourth Quarter 2012 Hampton Roads TOC Performance Measures Report shows the cumulative distribution of incident clearance (Figure 7). This graph allows analysts to determine the percentage of total incidents cleared within various times – in this case, within 10 minutes, 30 minutes, and 90 minutes.

Another nice graph from the same quarterly report (Figure 8) shows trends in the SSP average response and clearance times and includes VDOT’s clearance time goal as a comparison to the actual clearance times.

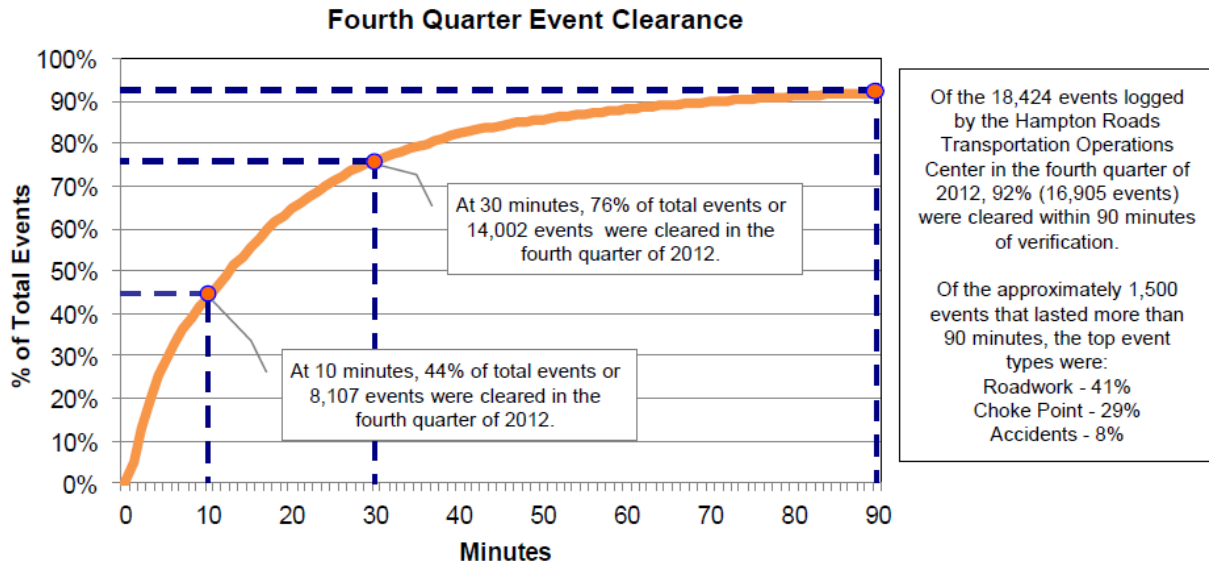
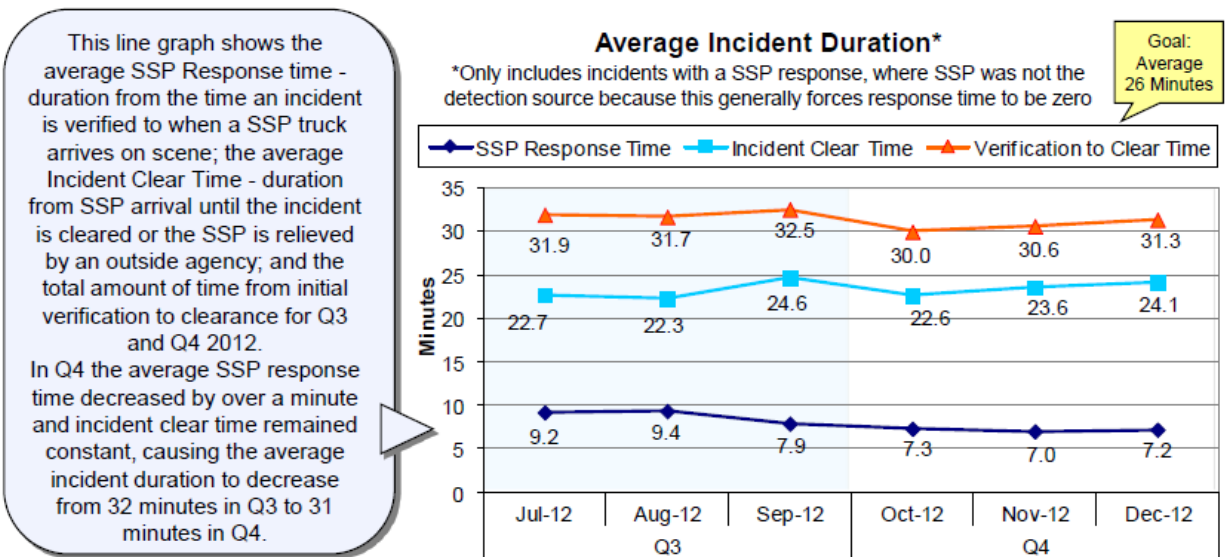

Figure 7. Fourth Quarter Incident Clearance Extracted from VDOT’s Hampton Roads TOC Fourth Quarter 2012 Performance Measures Report



---

*Figure 8. Average SSP Incident Clearance Trends Extracted from VDOT's Hampton Roads TOC Fourth Quarter 2012 Performance Measures Report*

### 5.1.2. Basic Dashboard Design

A well-designed TIM performance dashboard could help to quickly view performance in terms of the measures that have been identified as important or critical to NDOT and its TIM partners, as well as to make insightful observations regarding performance. The approach to designing the Nevada prototype TIM performance measures dashboard included a review of a wide variety of dashboards, as well as guidance and best practices in dashboard design.

Dashboards provide a common interface for interacting with and analyzing important business data and help to communicate progress and success. However, not all dashboards are created equal in terms of design and the information presented. An effective performance dashboard [14]:

- Is focused, thoughtful, and user-friendly.
- Communicates the key performance measures in a straightforward way.
- Is more than a lot of data on a screen; it has a core theme based on the essence of the problem.
- Contains useful, productive information as opposed to interesting but extraneous information.
- Can be broken into bite-sized pieces, each built around a key question.
- Allows users to drill down into the specifics.
- Is *not* meant to be a generic analysis tool used to slice and dice data to explore and answer a new question every time.

"Dashboard content must be organized in a way that reflects the nature of the information and that supports efficient and meaningful monitoring. Information cannot be placed just anywhere on the dashboard, nor can sections of the display be sized simply to fit the available space. Items that relate to one another should usually be positioned close to one another. Important items should often appear larger, thus more visually prominent, than less important items. Items that ought to be scanned in a particular order ought to be arranged in a manner that supports that sequence of visual attention [15]."

In the review, a few dashboard design principles were identified as important to the design of the Nevada TIM performance measures dashboard, including: compactness, guiding attention, supporting casual use, leading to action, and functionality (e.g., filters, drill down). In addition, several particularly well-designed dashboards were identified as models for the Nevada TIM performance measures dashboard and are shown in Figure 9 [16, 17, 18, 19] .



Figure 9. Examples of Four Well-Designed Dashboards



---

### 5.1.3. Nevada TIM Performance Measures Dashboard Mock-Up

Using the basic dashboard design principles and the visualization ideas from other dashboards, an initial mock-up of the Nevada TIM performance dashboard was developed. Based on TIM performance guidance from FHWA, the findings from other states' TIM performance reporting, and measure/reporting specific to Nevada, the primary information to be conveyed on the prototype dashboard included:

- Aggregate incident and performance statistics
- Performance measures appropriate for both urban and rural incidents
- Disaggregate performance statistics (to provide context)
- Performance trends
- 30-60-90-minute clearance times (similar to what FAST produces and reports to NDOT)

After the initial mock-up was created, queries were run on the data in the TIM performance measures database to produce the associated numbers and graphs to populate the mock-up dashboard.

Finally, Tableau was used as the platform for creating and displaying the dashboard. While there were many options available, Tableau offered several advantages:

- Quick and easy to get started
- No need to know SQL (unless more complicated analyses are required)
- Good visualization and built-in color palettes
- Ability to connect directly to most relational databases
- A user community with available examples

## 5.2. Overview of Nevada Prototype TIM Performance Measures Dashboard

Figure 10 shows a screenshot of the Nevada prototype TIM performance measures dashboard. Below the figure, each component of the dashboard is described in more detail.



Figure 10. Nevada Prototype TIM Performance Measures Dashboard

### 5.2.1. Incident Counts and Statistics

The upper left part of the dashboard (shown in Figure 11) presents aggregate incident statistics and TIM performance measures, specifically incident count, injury count, fatality count, aggregate average RT, aggregate average RCT, and aggregate average ICT. The total number of incidents shown in the upper left indicates the amount of data that is being analyzed and reflected in the rest of the dashboard statistics/graphs. In this example, there are 610 incidents, accounting for 333 injuries and 13 fatalities. The average RT, RCT, and ICT associated with these 610 incidents were 11, 62, and 76 minutes, respectively. This high-level data provided the scope for the remaining information/graphs shown on the dashboard.

Incidents	Injuries	Fatalities
<b>610</b>	<b>333</b>	<b>13</b>
Average RT	Average RCT	Average ICT
<b>11 min</b>	<b>62 min</b>	<b>76 min</b>

*Figure 11. Aggregate TIM Incident Statistics and Performance Measures*

### 5.2.2. Response and Clearance Trends

The graph covering the upper middle and right part of the dashboard (shown in Figure 12) shows the average RT, RCT, and ICT for each month in the analysis period – in this case, two years. This graph allows the user to compare how the aggregate average values vary month-to-month and identify any trends in performance. In this example, average RT held rather consistent over the two-year period, and while there is variability in average RCT and ICT month-to-month, there is no clear trend in performance in these areas. If, however, a new TIM strategy had been implemented, or a program had been expanded over the two-year period, this graph would indicate whether that strategy or expansion had any impact (and to what extent) on performance.

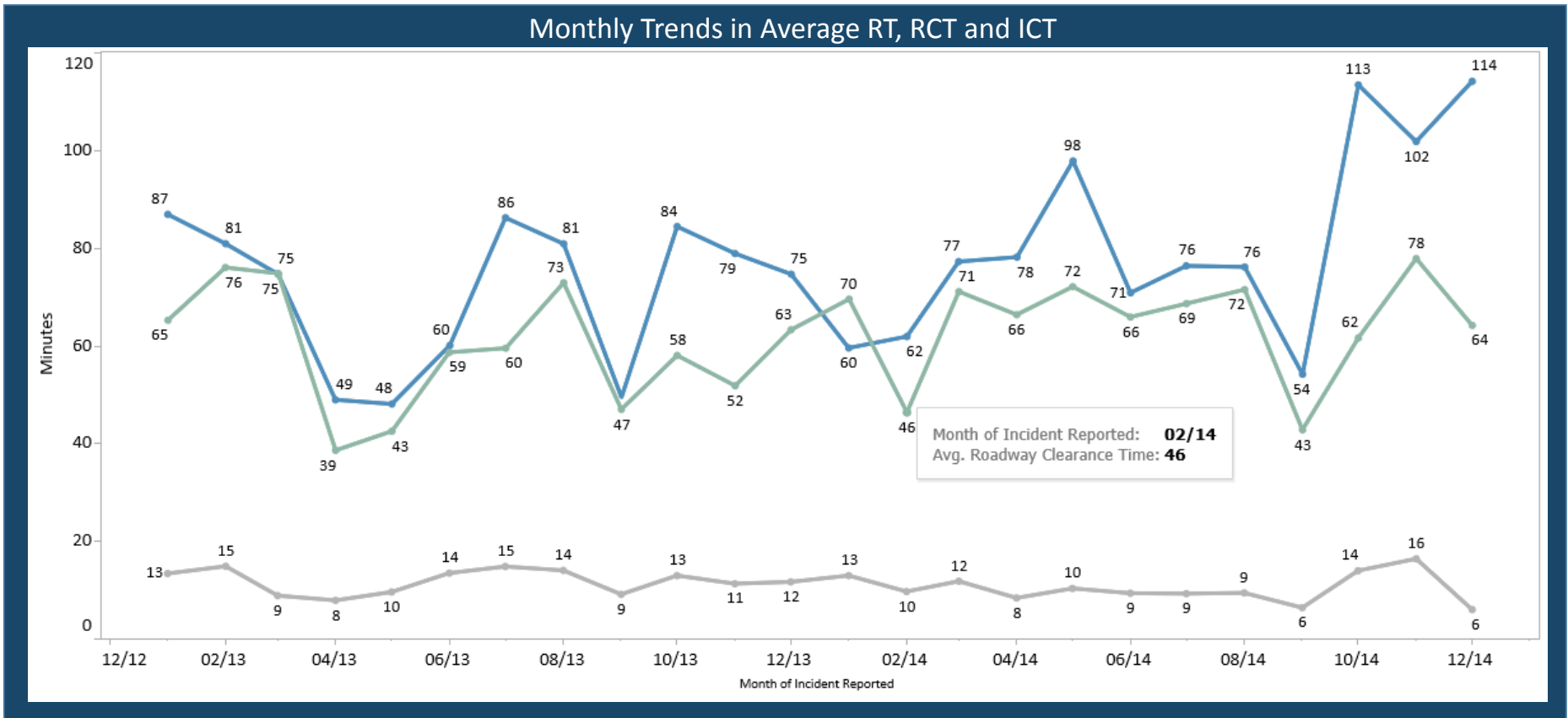

Figure 12. Incident Response and Clearance Trends

### 5.2.3. Clearance Times by Incident and Injury Type

The graphs shown across the middle part of the dashboard break down the aggregate average RT, RCT, and ICT shown above by incident type (shown in Figure 13) and injury severity (shown in Figure 14). These graphs provide a more refined look at TIM performance by putting the performance measures into a context – in this case incident type and injury severity. It would be expected that, in general, a crash would take longer to clear than a disabled vehicle or roadway debris. Likewise, it is intuitive that a crash involving a fatality would take longer to clear than a crash involving an injury or property damage only. However, when all incidents are taken together in the calculation of the performance measures, the differences are lost in the aggregate average values. These graphs put incidents in a similar context by type and severity and show the resulting average performance measures, where the differences can be seen clearly in most cases. Having access to these graphs would help NDOT and the Nevada TIM partners to set performance goals for different types of incidents and then to track and monitor performance against those goals accordingly.

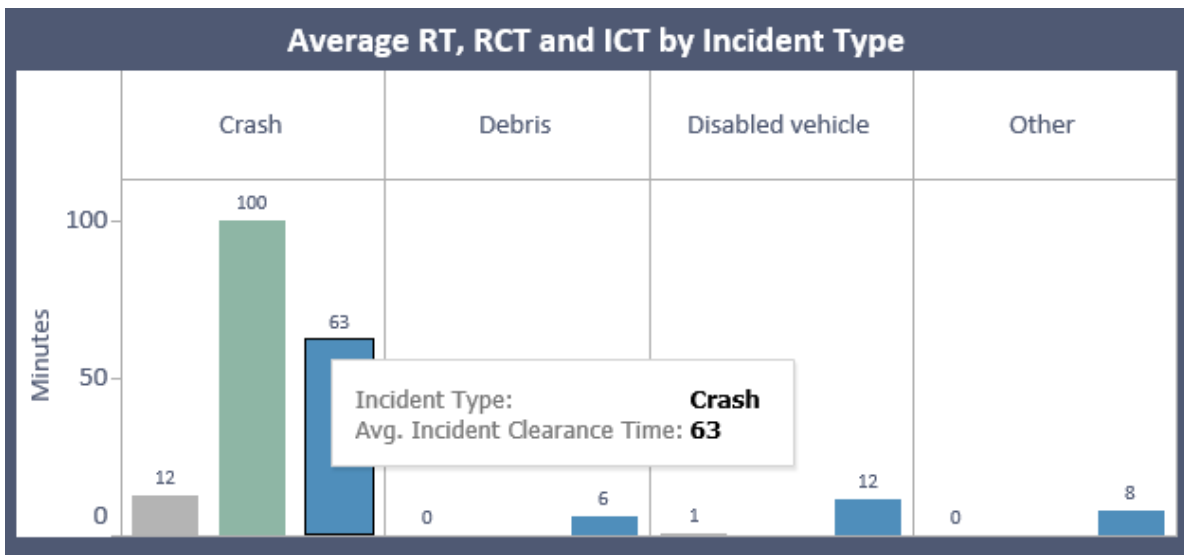

Figure 13. Average RCT and ICT by Incident Type

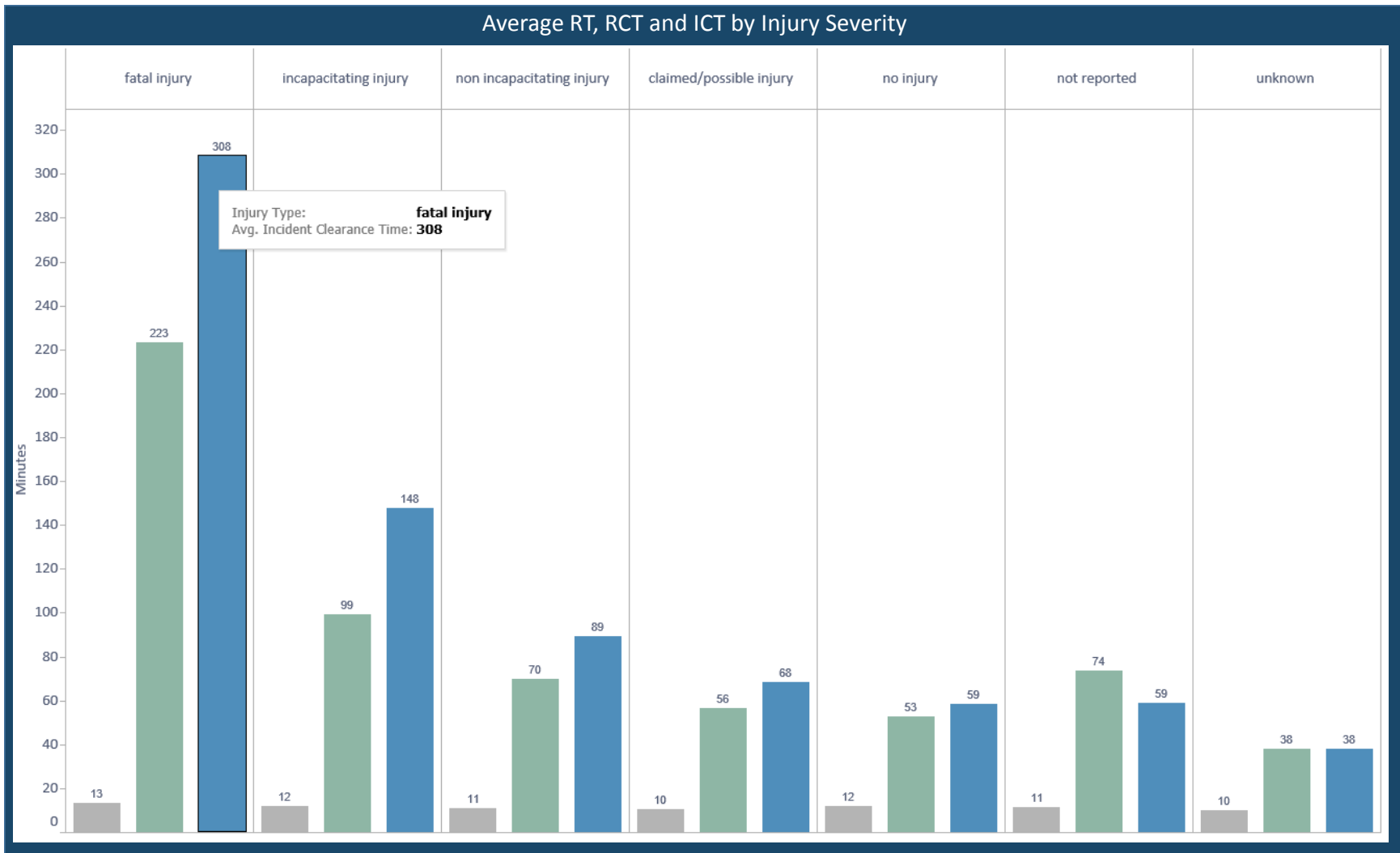

Figure 14. Average RT, RCT and ICT by Injury Severity

#### 5.2.4. 30-60-90 Minute Clearance Performance

The graphs in the lower left and lower middle parts of the dashboard indicate TIM performance against the 30-60-90-minute clearance criteria/goals. These graphs show the cumulative distribution curves for RCT and ICT – in other words, the percentage of incidents that were cleared within the range of clearance times. Figure 15 shows that 17, 44, and 63 percent of incidents were cleared from the travel lanes (RCT) within 30, 60, and 90 minutes, respectively. Likewise, Figure 16 shows that 10, 28, and 45 percent of the incidents were completed cleared from the roadway (ICT) within 30, 60, and 90 minutes, respectively. The dashboard allows the user to hover over any point along the cumulative distribution curve to see the RCT or ICT and the percent of all incidents cleared within that time. Having access to these graphs would help NDOT and the Nevada TIM partners to set RCT and ICT clearance goals – such as clearing 50 percent of the incidents from the roadway within 30 minutes, 75 percent of the incidents from the roadway within 60 minutes, and 90 percent of the incidents from the roadway within 90 minutes – and then to track and monitor performance against those goals.

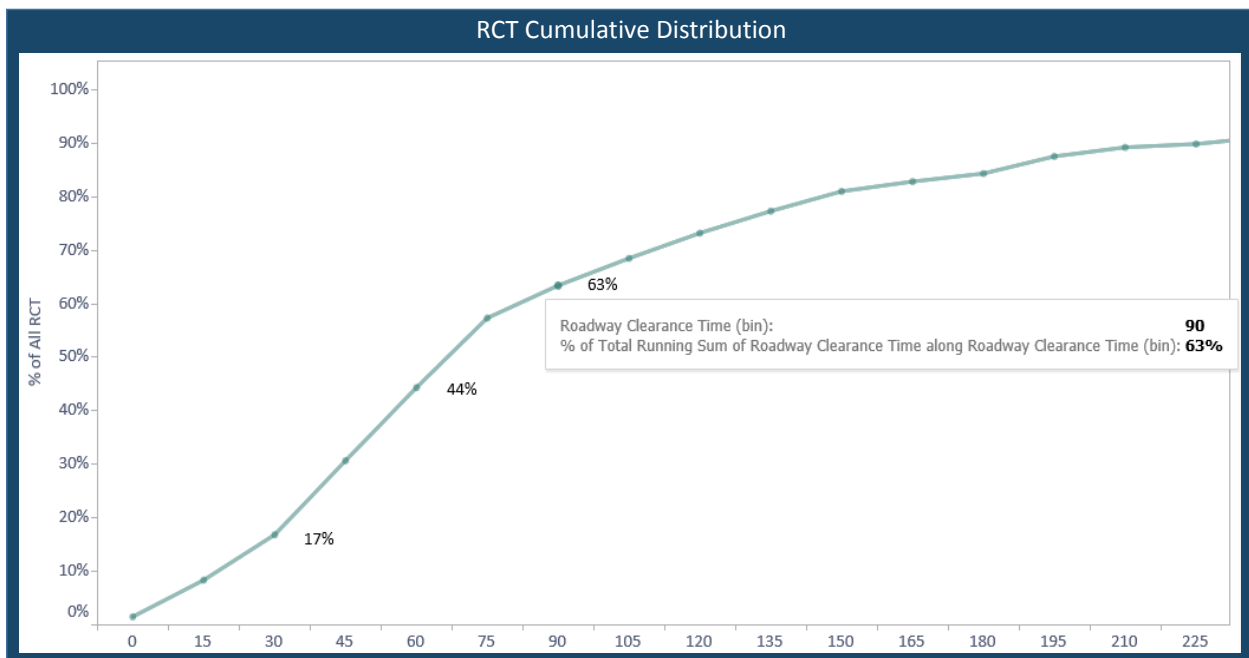

Figure 15. 30-60-90 Minute Roadway Clearance Performance

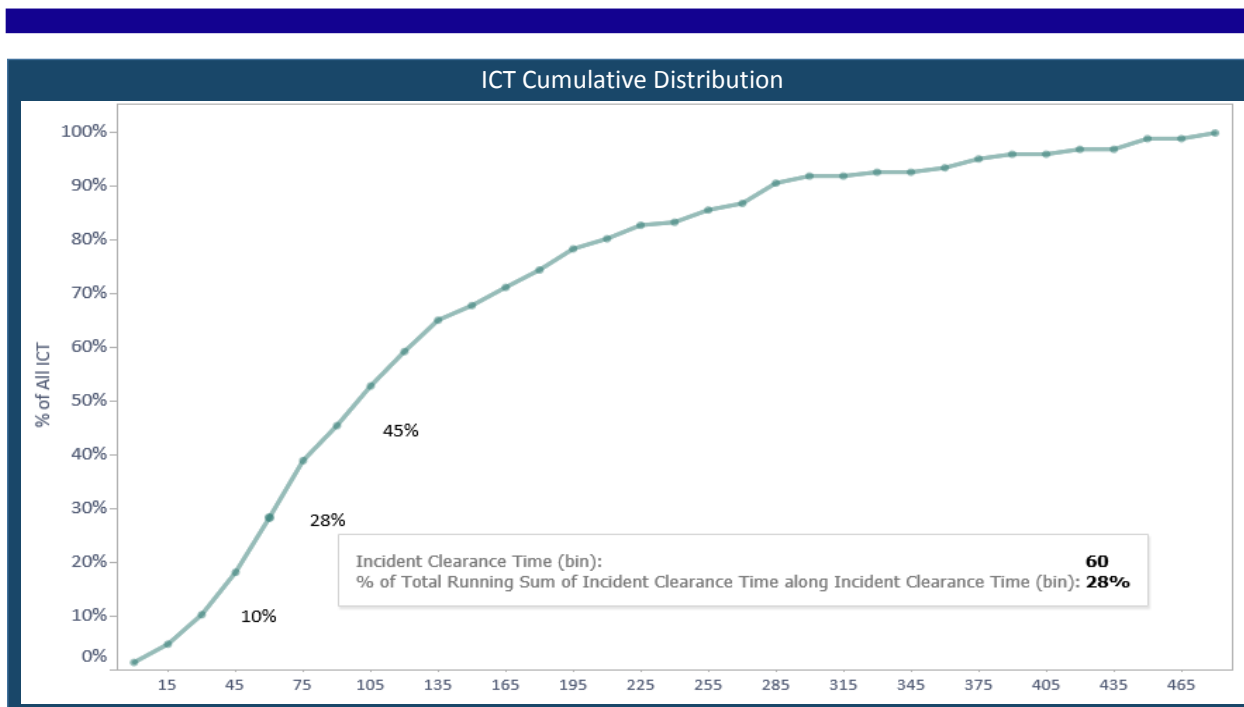

Figure 16. 30-60-90 Minute Incident Clearance Performance

### 5.2.5. FSP Assists

Finally, the diagram in the lower right part of the dashboard (shown in Figure 17) is a word cloud that displays the words most often entered by FSP operators when assisting motorists. The larger the words appear in the diagram, the more often they are found in the database. Figure 17 indicates that for this analysis location and period, FSP operators most often indicated that they assisted a “disabled” vehicle. “Mechanical” issues, “flat” tires, and “abandoned” vehicles also made up a good proportion of the FSP assists. Other assistance types can be identified through words including “provided,” “fixed,” “gave,” and “pushed.” “Safety” was also noted as an issue quite frequently by FSP operators. Within the dashboard interface, hovering the cursor over each word provides the number of times that the word appears in the database – as shown, the word “removed” appeared in 701 instances. A similar diagram showing the words most commonly found on the traveler response cards might also be of interest to NDOT.

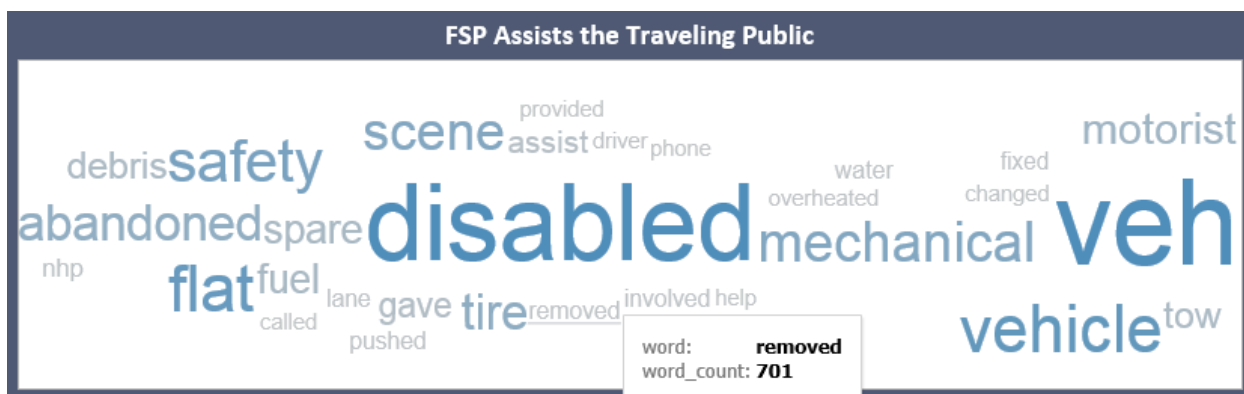

Figure 17. FSP Assists



### 5.2.6. Incident Map

In addition to the metrics, graphs, and diagrams discussed above and shown on the main page of the dashboard, the dashboard also includes an “Incident Map” tab. When selected, this tab displays a map with the locations of the incidents included in the calculations. Figure 18 shows a statewide view of the 601 incidents. The times displayed next to the dots are the response times for those incidents. When hovering the cursor over any particular incident, the dashboard displays the RT, RCT, and ICT, as shown for one incident.

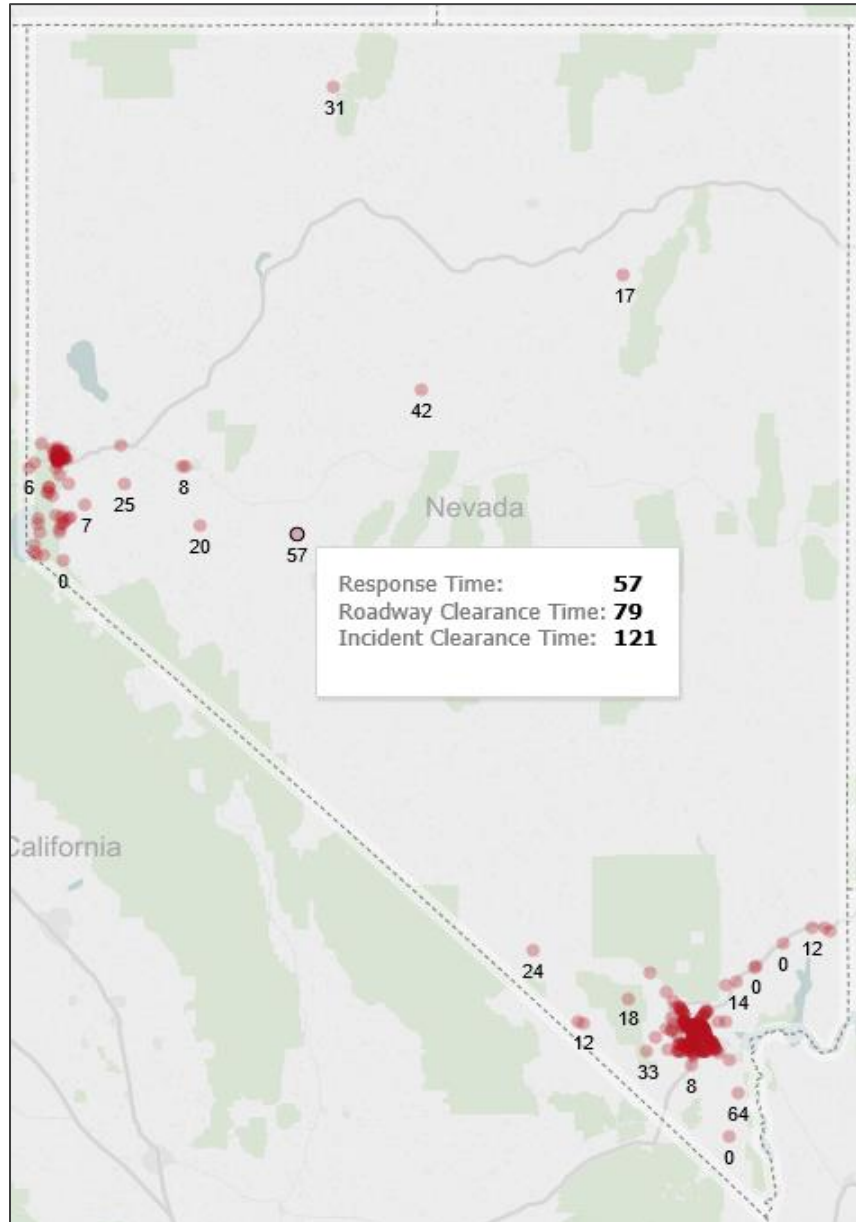

Figure 18. Incident Map – Statewide

The dashboard also allows the user to zoom into a particular location for a closer look at not only the geographic distribution of the incidents, but also a closer look at the response and clearance times for those incidents. Figure 19 shows a map of the incidents in and around the Reno-Carson City area. This map shows more clearly the response times for the incidents in this area. It might also be noted that, in general (as might be expected), the incidents in the cities have lower response times than the incidents further out. Figure 20 shows a similar map of the incidents in and around the Las Vegas area.

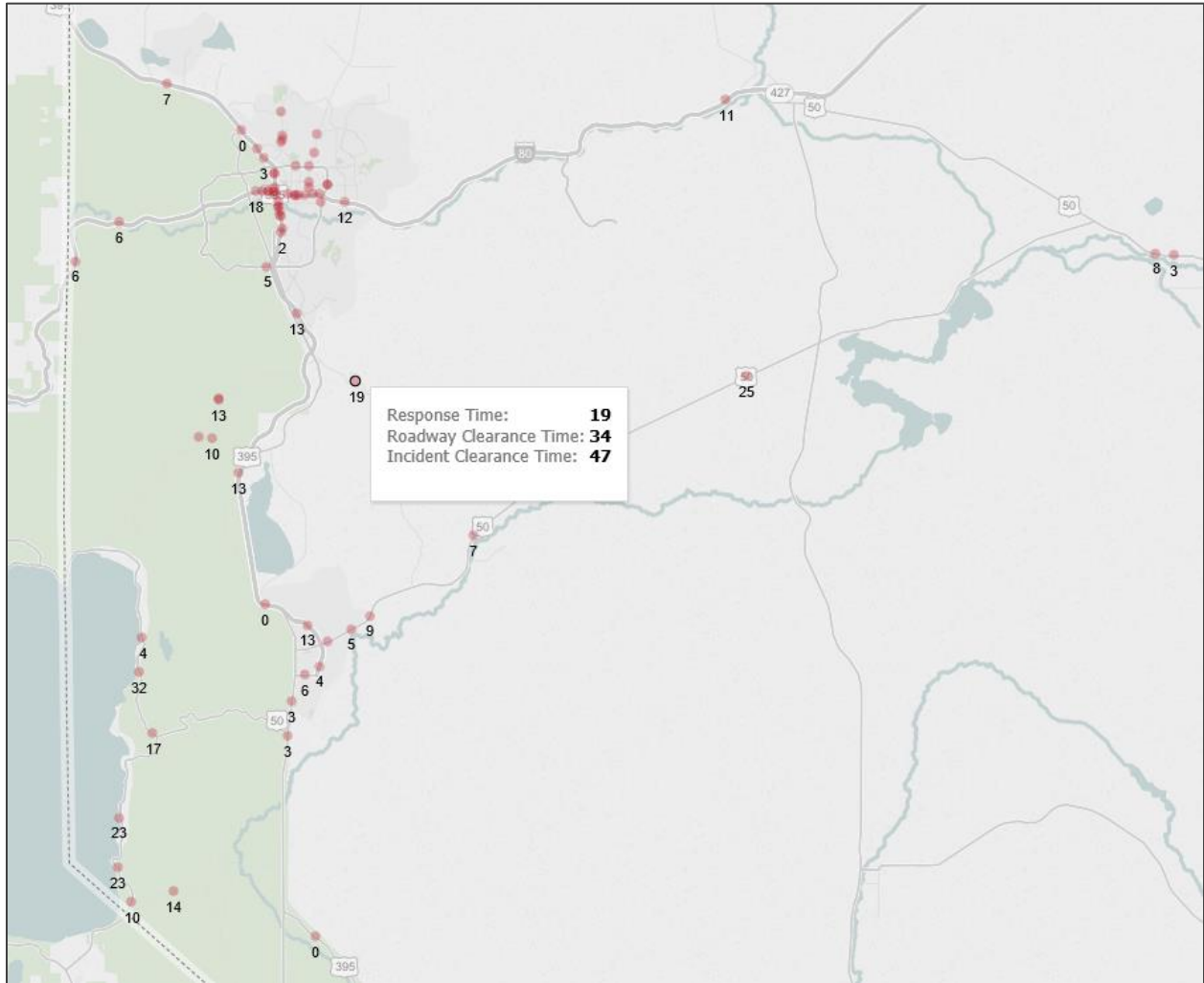

Figure 19. Incident Map – Reno-Carson City and Surroundings

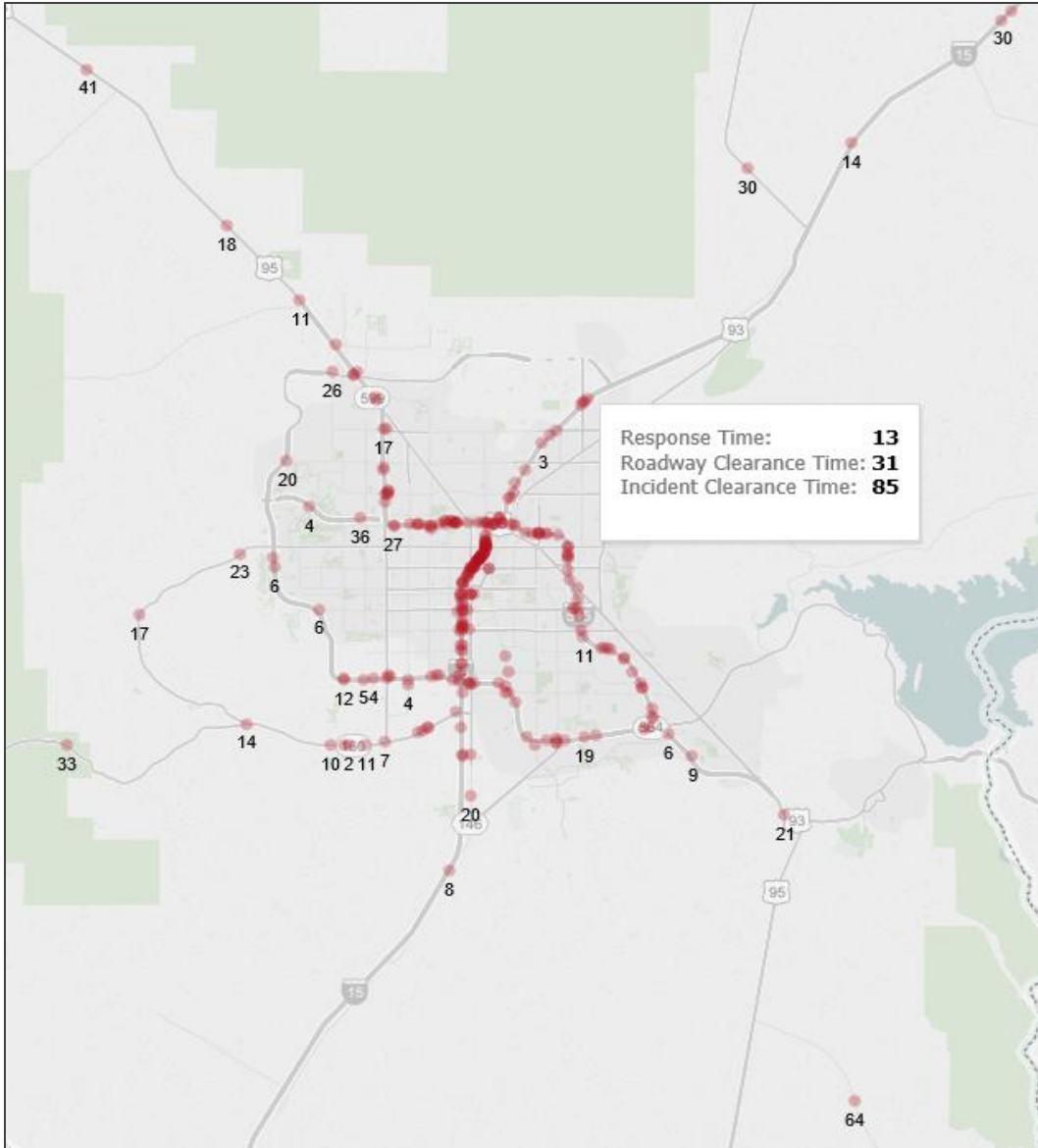

Figure 20. Incident Map – Las Vegas Area

### 5.2.7. Interactive Filtering Capability

Finally, the Nevada prototype TIM performance measures dashboard has in interactive filtering capability that allows users to choose from a variety of filters to display the performance measures and map. Using these filters, performance can be quickly viewed by “date range” (using the slider to adjust the beginning and end date), “state” (in this case, Nevada), “locale” (urban or rural), “quarter” (Q1, Q2, Q3, Q4), year (in this case, 2013, 2014, and 2015), “city” (157 cities/towns in Nevada), and “weather” (clear-day, cloudy, fog, party-cloudy-day, party-cloudy-night, rain, snow, wind) (Figure 21). The incident statistics, performance measures, and graphs adjust according to the filters selected, as does the map displaying the location of the incidents. This capability would allow NDOT and the TIM partners to view

---

performance for various time periods, locations, and weather conditions (or all of the above) and identify when, where, or under what conditions performance may not be up to par.

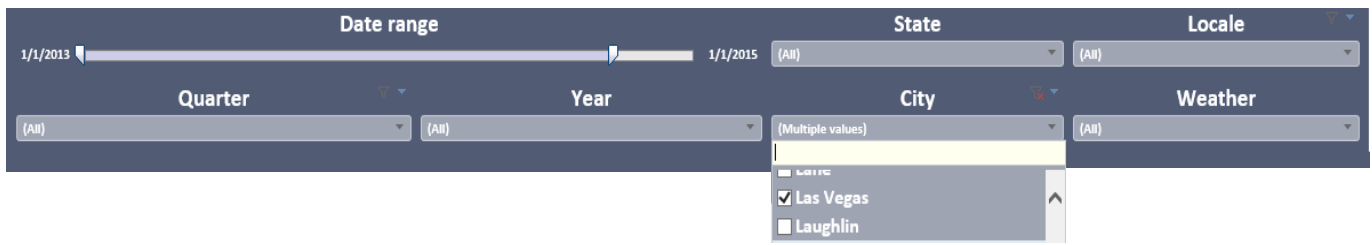

Figure 21. Dashboard Filtering Capabilities

---

## 6. SUMMARY AND RECOMMENDATIONS TOWARDS IMPLEMENTATION

### 6.1. Summary

This research project has accomplished a number of objectives, including:

1. A literature review and selected interviews with several leading state agencies helped to establish the state-of-the-practice in TIM performance data collection, analysis, and reporting. The findings presented in this report can be used by NDOT and its TIM partners to find and assess new, different, and more effective ways of collecting and managing incident data for the purpose of TIM performance analysis.
2. Five different sources of incident data were assessed to determine the quantity and quality of incident data available across the state of Nevada. The quantity of data was assessed in terms of the total numbers/coverage of incidents in each dataset. The quality of the data was assessed using the NCHRP 07-20 data model and the corresponding “TIM PM checklist” as a benchmarking tool. The findings can help NDOT and its TIM partners to better understand which of the required and desired TIM performance data elements are available in each dataset, as well as where the data gaps are that need to be filled.
3. A step-by-step process was developed to integrate the incident data from the various datasets. While the data were integrated to the extent possible, a number of challenges and limitations were identified during the process. The integration of the data provided a subset of the incident data provided (which did represent a statewide sample of incidents) for which TIM performance could be analyzed and reported. Recommendations for improving the quantity and quality of the incident data are provided within this report.
4. An interactive prototype TIM performance dashboard was developed and demonstrated to the Nevada TIM partners. The prototype dashboard provides consistent TIM performance measures (including aggregate and disaggregate measures of performance) for incidents across the state, and the measures are calculated by querying the integrated database. The prototype dashboard allows users to filter TIM performance analyses by a number of factors including timeframe, location, urban vs. rural, and weather conditions.

The following section provides recommendations for NDOT and the Nevada TIM partners to move the work performed and the resulting products from this research towards implementation.

### 6.2. Recommendations

This research project has uncovered best practices in incident data collection and TIM performance analysis, as well as challenges and limitations associated with the available incident data in Nevada for conducting these types of analyses. As a result, there are a number of recommendations for NDOT and the Nevada TIM partners that would help to fill some of the data gaps and improve the quantity and quality of data available for more robust TIM performance analysis on a statewide basis. These recommendations are discussed below:

- *Focus on improving the times and locations of the incidents, the most critical data elements for analyzing TIM performance* – Time stamps representing the important points along the incident timeline (and consistent with the FHWA definitions) are absolutely critical to calculating the RT,

---

RCT, and ICT performance measures, as well as others. In addition, the exact incident location, in terms of latitude and longitude, is also critical in order to geo-locate the incident, filter for performance analyses (e.g., by NDOT district), and identify other data elements associated with the incident. While the collection of cross street and mile marker location is common, the ability to collect the latitude and longitude at an incident scene would greatly aid in the data integration and analysis process. Good quality geo-coordinates could be later processed using reverse geocoding and a GIS service to automatically infer many other data fields, including roadway name, city, county, state, and even weather information (if known in conjunction with the incident time). Specific recommendations include:

- Work to find ways to obtain and record latitude and longitude for all FSP assists (e.g., use of mobile devices with GPS).
- Improve geo-referencing for crashes statewide (some incidents are geo-referenced and others are not).
- Work to find ways in which to improve and standardize the reporting and recording of important events, including the time of first awareness of an incident by a responsible agency, the time the incident is verified, the time in which the first responder arrives on the scene, the time in which the travel lanes are opened, and the time that the *last* responder (not simply the last police officer) has left the scene. Specifically:
  - FSP and NHP should collect the time in which the travel lanes are opened for each event, including debris on the road and disabled vehicles.
  - NHP and other responder agencies should collect the time that the last responder has left the scene.
  - NNROC and FAST should collect the time that normal traffic flow returns for all incidents including non-crash incidents.
- *Obtain and integrate additional responder data (e.g., fire, EMS, towing)* – None of the response agencies collect all of the data elements important to developing a better understanding TIM performance. While transportation agencies and the state police collect a lot of data on a lot of incidents, they will likely not have specific data elements associated with other responders; and there are many incidents throughout the state in which neither the state DOT nor the state police are present. For example, there were over 48,000 crashes from the LVMPD alone, and these could not be included in the data integration process because the LVMPD CAD data were not available. This represents a very large gap in crashes from the TIM performance analysis. In addition, from early conversations with the Clark County Fire Department (CCFD), it was determined that the CCFD CAD data would provide additional details about incidents, such as the type/severity of the incidents and the number of and arrival/departure times of fire personnel/vehicles on the scene. Obtaining and integrating the LVMPD and the CCFD CAD data with the NDOT-NHP-FSP database will improve not only the quantity of the data, but also the quality of the data, and will add value to the TIM performance analyses.
- *Work to improve the collection of other desired TIM PM data elements* – Currently there are many gaps in the data as compared to the NCHRP 07-20 data model. Data elements such as the total number of lanes at the scene, the number of lanes blocked, and the number of participants/vehicles/responders involved, would add value to the TIM performance analysis

---

and the determination of when and where improvements are needed. In this project, the count of NHP responders at an incident had to be inferred from the CAD log by counting the distinct unit number for each incident response. While this is a good start, the information is not detailed enough for more complex analyses.

- *Standardize use of call/incident numbers for incidents* – To ease the data integration process, NNROC, FAST, and the FSP should collect the call or incident number used by the other responders (e.g., NHP) at the incident scenes. Recording this information would allow the TMC data to be more effectively merged with the other responding agencies' incident data by avoiding the creation of duplicate entries in the TIM PM database and facilitating the matching of FAST incident records with NHP incident records.
- *Identify secondary crash cause* – Flagging a crash as a secondary crash is helpful in identifying how many secondary crashes occur and if they are increasing or decreasing, but it does little to identify the cause of the secondary crash. Linking a secondary crash to its parent crash/incident in the data by collecting the parent crash/incident ID when recording the secondary crash information would be valuable. It would allow for parent crashes/incidents to be identified, and for common patterns or situations leading to secondary to be uncovered, by examining them separately from the rest of the incidents.
- *Leverage external datasets* – Unless required for other purposes, the collection of weather information, for example, is unnecessary and too limited. Relying on external datasets to get more detailed information (assuming time and location is known) is a better and more reliable approach. Eventually traffic conditions, local events, etc. could also be added to the data to further refine the TIM PM analysis.
- *Move towards full implementation* – While just a pilot study and a prototype database and dashboard, the outputs of this research project have established a solid foundation and platform on which NDOT can build. Specific recommendations on working towards full implementation of the TIM PM database and dashboard include:
  - Adjust policies and requirements to optimize TIM data collection at each data source/partner.
  - Develop and standardize data ingestion processes for each of the data sources/partners so that they are standardized and repeatable.
  - Deploy a full-size database either on premise or in the cloud to store integrated TIM data.
  - Implement a reporting/dashboard system to visualize/report TIM performance and trends.
  - Develop TIM PM reports and custom analyses to be run on the reporting/dashboard system.
  - Define and set up reporting/dashboard system users, their access rights, and their associated report delivery schedules.
  - Perform regression and performance testing on the data ingestion/integration processes and the database/reporting/dashboard system.
  - Develop and set up ingestion processes, a database, and a monitoring system to ensure stable and acceptable system performance and to perform system maintenance (archive older TIM data, retire unused reports and dashboard components).

---

## REFERENCES

- [1] J. L. Carson and R. E. Brydia, "Traffic Incident Management Performance Metric Adoption Campaign." Draft final report., " Federal Highway Administration, USDOT, Washington, DC, August 2011.
- [2] K. K. Pecheux and R. E. Brydia, "NCHRP 07-20: Guidance on the Implementation of Traffic Incident Management Performance Measurement," Transportation Research Board,, Washington, DC, November 2014.
- [3] FHWA, "Traffic Incident Management," April 2004. [Online]. Available: [http://ops.fhwa.dot.gov/aboutus/one\\_pagers/tim.htm](http://ops.fhwa.dot.gov/aboutus/one_pagers/tim.htm). [Accessed 15 October 2013].
- [4] M. Grant, J. D'Ignazio, A. Bond and A. McKeeman, "Performance Based Planning and Programing Guidebook," FHWA, USDOT, Washington, D.C., 2013.
- [5] United States Department of Transportation, "Incident Information Architectural Flow," The National ITS Architecture 7.0, Washington, D.C., 2015.
- [6] FHWA, "2013 Traffic Incident Management National Analysis Report," FHWA, USDOT, Washington, D.C., 2013.
- [7] K. K. Pecheux, "Process for Establishing, Implementing, and Institutionalizing a TIM Performance Measures Program, FHWA-HOP-15-028," Federal Highway Administration, USDOT, Washington, DC, pending publication.
- [8] Noblis, "Review of Traffic Incident Management Evaluation Methods - NCHRP Project 03-108, Task 2B," Interim Report (not published), June 2014.
- [9] N. D. Owens, A. H. Armstrong, C. Mitchell and R. Brewster, "FHWA Focus State Initiative: Traffic Incident Management Performance Measures Final Report. FHWA-HOP-10-010," Federal Highway Administration. U.S. Department of Transportation, Washington, DC, December 2009.
- [10] C. Conklin and et al., "Modified from the incident timeline presented in Transportation Management Center: Data Capture for Performance and Mobility Measures Guidebook," FHWA, USDOT, Washington, D.C., 2013.
- [11] FHWA, "Traffic Incident Management Self-Assessment.," [Online]. Available: [http://ops.fhwa.dot.gov/eto\\_tim\\_pse/preparedness/tim/self.htm](http://ops.fhwa.dot.gov/eto_tim_pse/preparedness/tim/self.htm). [Accessed 2014 28 April].
- [12] NDOT, "Statewide Integrated Transportation Reliability Program – Technical Memo No. 7 – Implementation Plan," <http://www.kimley->



---

horn.com/projects/NevadaITRP/images/pdfs/Technical%20Memo7\_Implementation%20Plan-04-10.pdf, April 2010.

[13] AZDPS, "“An Overview of Our Traffic Incident Management Initiative”," unpublished PowerPoint Presentation by Arizona, June 4, 2012.

[14] I. Juice, "A Guide to Creating Dashboards that People Will Love," 2009.

[15] "Pervasive Hurdles to Effective Dashboard Design," Visual Business Intelligence Newsletter, 2007.

[16] C. Lake, "24 Beautifully-Designed Web Dashboards That Data Geeks Will Love," Econsultancy, 3 June 2013. [Online]. Available: <https://econsultancy.com/blog/62844-24-beautifully-designed-web-dashboards-that-data-geeks-will-love/>. [Accessed 3 May 2016].

[17] L. Wang, "What are the best Dashboard designs, and why?," Quora, 5 February 2012. [Online]. Available: <https://www.quora.com/What-are-the-best-Dashboard-designs-and-why>. [Accessed 3 May 2016].

[18] Damir, "20 Free Bootstrap 3 Admin Dashboard Templates For Your Web App 2016," colorlib, 31 March 2016. [Online]. Available: <https://colorlib.com/wp/free-bootstrap-admin-dashboard-templates/>. [Accessed 3 May 2016].

[19] "Dashboards and Reporting," Sassafras Software, [Online]. Available: <http://www.sassafras.com/usage-optimization-reports/>. [Accessed 3 May 2016].

---

## APPENDIX A – INTERVIEW QUESTIONS

- Provide background/intro to projects.
- According to the 2014 TIM SA, [state] reported [X] national TIM PMs.
  - Can you explain where and how the data come from (for each location) to calculate the TIM PMs being reported in the TIM SA (e.g., TMC, FSP, LE)?
    - Any LE data (state or local) being used?
      - If so, are the data electronic?
      - Do local LE use this? All local jurisdictions, or just some?
    - How are TIM data shared/integrated, if at all?
  - For what roadways are TIM PMs being reported (e.g., all within TMC range, all within FSP coverage, all state highways/Interstates)?
  - For what types of incidents (e.g., crashes only, minor including non-crashes, all incidents on these roadways, major crashes only, etc)?
  - If there were or are gaps in data for reporting the TIM PMs, how have you or how do you plan to fill these gaps?
  - Not many agencies are reporting secondary incidents. What has been your processes for successfully doing so?
- How are the local areas and/or the state using these data/PMs (e.g., internally for performance monitoring and/or decision making, reporting to stakeholders/public)?
  - Can you share any sample performance reports/visualizations of TIM PMs?
- Can you share any examples of benefits you have experienced from the collection/reporting of the TIM PMs?
- What interagency coordination/formal or informal agreements are in place to support TIM PM data collection and reporting in [state]?
  - Who has the lead?
- Have steps/processes been used to formalize/implement TIM PM data collection and reporting? (e.g., agreements, governor's office, TRCC, SHSP, HSP, TIM Coalition).
- Most DOTs focus on TIM performance measurement within metropolitan areas because that's where they have the ITS/ATMS coverage. In states like Arizona and Florida, the state highway patrol has become involved and has even taken the lead in gathering the TIM data elements. This is because they are at more incidents (outside of DOT coverage areas), including urban arterials and rural areas. Has [state] given any thought to TIM performance (the importance of, how the data would be collected, etc.) outside of the urban areas?
- Would [state] be interested in participating in some sort of national TIM PM program (i.e., reporting/sharing data)?

## APPENDIX B – CASE STUDIES

### Oregon TIM Performance Measurement Case Study

#### Overview of TIM Program

Operations in the Oregon Department of Transportation (ODOT) are divided into five geographical regions: Portland Metro (Region 1), Willamette Valley (Region 2), Southern Oregon (Region 3), Central Oregon (Region 4), and Eastern Oregon (Region 5).<sup>3</sup> Each are individually responsible for construction and maintenance projects in that region. The state of Oregon is also divided into 14 maintenance districts that handle the day-to-day maintenance and operations of state highways.<sup>4</sup> Maps of the regions and districts can be seen in Figure 22.<sup>5</sup> There is a traffic operations center (TOC) in each of the regions, and incident reports for all incidents on state highways, of which ODOT is aware, are created and tracked in the TOC system.

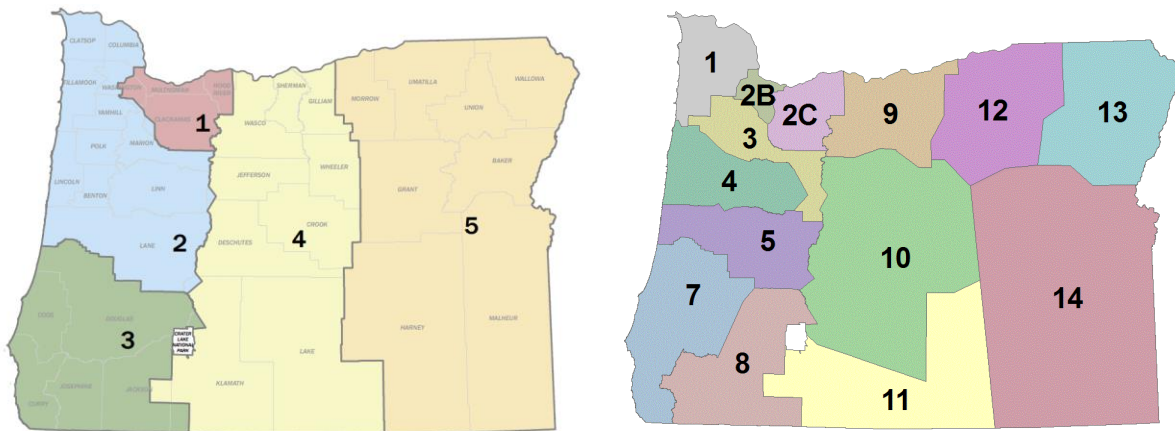

Figure 22. Map of Five Regions and 14 Districts, Respectively, in Oregon

There is a formal Declaration of Cooperation – signed in November 2013 – between ODOT and the Oregon State Police (OSP) to coordinate incident response at the statewide level, committing to the support of the TIM training and its principles.<sup>6</sup> There are also informal agreements at lower, regional or district levels, between ODOT, law enforcement, and other responders. There are regional TIM teams that are committed to meeting on a regular basis to review incident response in that region and to discuss potential improvements.

<sup>3</sup> Oregon DOT, ODOT Regions, <http://www.oregon.gov/odot/pages/highwayregions.aspx>, accessed March 8, 2016.

<sup>4</sup> Oregon DOT, Maintenance and Operations Branch, [http://www.oregon.gov/ODOT/HWY/OOM/pages/about\\_us.aspx](http://www.oregon.gov/ODOT/HWY/OOM/pages/about_us.aspx), accessed March 8, 2016.

<sup>5</sup> Oregon DOT, GID Unit Map Products, <http://www.oregon.gov/ODOT/TD/TDATA/pages/gis/odotmaps.aspx>, accessed March 8, 2016.

<sup>6</sup> Oregon Technology Transfer Center, Oregon Roads Newsletter: Spring 2015, [http://www.oregon.gov/ODOT/TD/TP\\_T2/news/OregonRoads107.pdf](http://www.oregon.gov/ODOT/TD/TP_T2/news/OregonRoads107.pdf).

---

## Data Collection and Management

In 2009, a new advanced traffic management system (ATMS) was implemented in Oregon to replace the individual regional systems. This statewide system provides ODOT with the ability to coordinate and track incident response across the state in a more efficient and organized manner.<sup>7</sup> While the incident-reporting process at the TOCs relies on the TOC operators communicating with 911 operators and manually inputting this information into the incident reports, ODOT is working on integrating the system with the 911 computer-aided dispatch (CAD) software. The integrations are already operational in a few counties.

ODOT has a limited number of incident response FSP staff that are dispatched to both major and minor incidents on state highways, as necessary. Responders from either ODOT's incident response teams or partner agencies call in incident information to the TOC, and the operators enter the information into the ATMS. The TOC operators also monitor closed-circuit television (CCTV) cameras for incidents. The data entered into the system is dependent on the TOC operators receiving information from responders that is valuable and useful and the TOC operators carefully monitoring the CCTVs. More outreach to partner agencies, specifically law enforcement, regarding the value of good data collection techniques would be helpful in improving the data that is collected statewide. ODOT is working on improving communication to show the partner agencies the full capabilities of the data systems and to agree on a consistent data format for responders to collect.

All districts in Oregon collect data on both roadway clearance time (RCT) and incident clearance time (ICT), and many individually report these measures to the Federal Highway Administration (FHWA) via the annual TIM Self-Assessment (TIM SA). While ODOT does not yet collect data on secondary crashes, it has a tool to calculate the risk of secondary crashes. The tool employs a model developed by Karlaftis et al. that predicts the likelihood of a secondary incident for every minute of an active incident.<sup>8</sup> As a part of an update to the TIM Strategic Plan, which will be completed in 2016, ODOT plans to examine the practices in other states with respect to the collection of secondary crash data and then to determine what approach is best for Oregon.

## Performance Analysis and Reporting

ODOT has worked together with OSP and other responder agencies to reach a shared understanding of TIM goals and objectives throughout the state. The key TIM performance target in Oregon is to clear the roadway for every incident in less than 90 minutes.<sup>9</sup> ODOT continues to work on the accuracy of incident start times. The ATMS, CAD system, and police reports generally all contain slightly different times depending on how the incident was identified and verified. This issue is also one of the drivers for the planned integration of the ATMS and the CAD system.

---

<sup>7</sup> Oregon State University, New Traffic Management System in Oregon Now Online, <http://oregonstate.edu/ua/ncs/archives/2009/jul/new-traffic-management-system-oregon-now-online>, accessed March 8, 2016.

<sup>8</sup> Karlaftis, M. G., S. Latoski, P. Richards, J. Nadine, and K. C. Sinha. ITS Impacts on Safety and Traffic Management: An Investigation of Secondary Crash Causes. *Journal of Intelligent Transportation Systems*, Vol. 5, No. 1, 1999, pp. 39–52.

<sup>9</sup> Oregon State Police, Traffic Incident Management, [http://www.oregon.gov/osp/PATROL/Pages/Traffic\\_Incident\\_Management.aspx](http://www.oregon.gov/osp/PATROL/Pages/Traffic_Incident_Management.aspx), accessed March 8, 2016.

---

Although there is now a statewide ATMS, TIM performance measurement, analysis, and reporting in Oregon is handled at a district level. While District 2 (Portland) is the only district required to complete an annual TIM SA, about half of the other districts do as well, and these are typically the districts that have dedicated incident response teams. ODOT is working on finding ways to distribute the performance measure data to mid- and upper-level management in partner response agencies, as well as to the TIM teams throughout the state with the goal of agreeing on a format that will support improved performance management.

In order to move closer to achieving the statewide goal of clearing 100% of incidents in under 90 minutes, ODOT has identifies and analyzes all incidents with an RCT over 90 minutes. ODOT focuses on determining the reasons the goal was not met and engages specific partners to identify areas where improvements could be made. After-action reviews are conducted for each incident, but ODOT has also looked for trends, both statewide and on a regional level. While this initial analysis was helpful, it was performed manually, and ODOT has tasked their regional TIM teams to find a more automated solution.

ODOT Region 1, Maintenance District 8 is actively engaged in a pilot project to analyze a Dedicated Incident Response program. The objective of this pilot project is to demonstrate the value for dedicated response teams in a district where all incident response was previously handled by maintenance staff, either in addition to their maintenance responsibilities during standard work hours or as on-call responders after hours. A detailed analysis was conducted at the two-year mark of the pilot project. Figure 23 and Figure 24 were excerpted from the Final Performance Evaluation and Findings Report.<sup>10</sup> Figure 23 shows the percentage of incidents that were cleared within 90 minutes by the incident responder (IR) and the maintenance crews (MC) before and during the pilot project. Figure 24 compares the overall percentage of incidents that met the clearance goal before and during the pilot project.<sup>11</sup> These results show that having a dedicated incident responder resulted in more incidents being cleared within the 90-minute goal.

---

<sup>10</sup> Oregon DOT, ODOT Region 3 District 8 Dedicated IR Program Evaluation: Final Performance Evaluation and Findings Report, December 2015.

<sup>11</sup> Griffin, J., Dedicated Incident Response Pilot Program Evaluation Findings, Presentation from Statewide TIM Meeting, September 22, 2015.

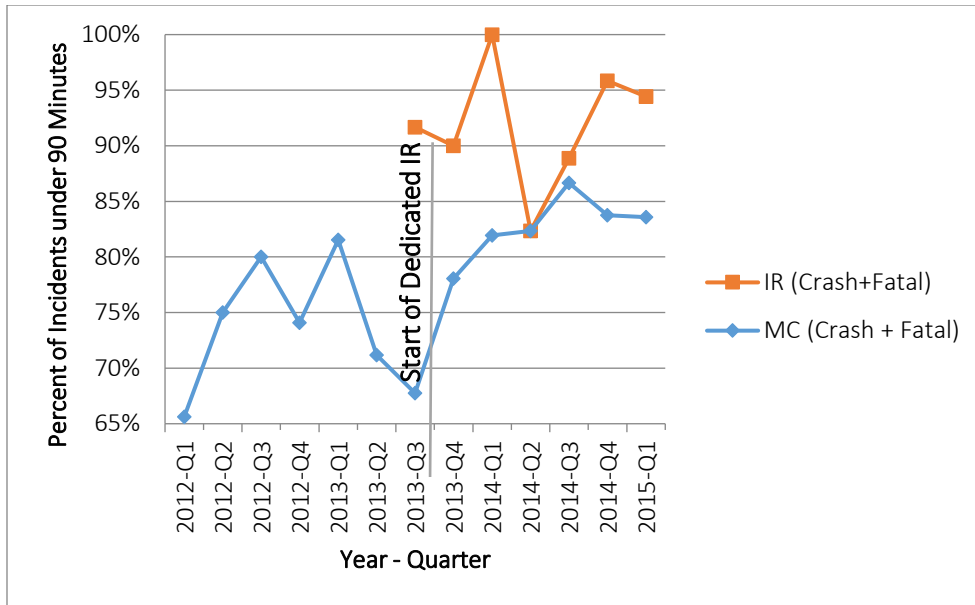

Figure 23. District 8 Pilot – Percent of Crashes Cleared within 90 Minutes by Responder Type

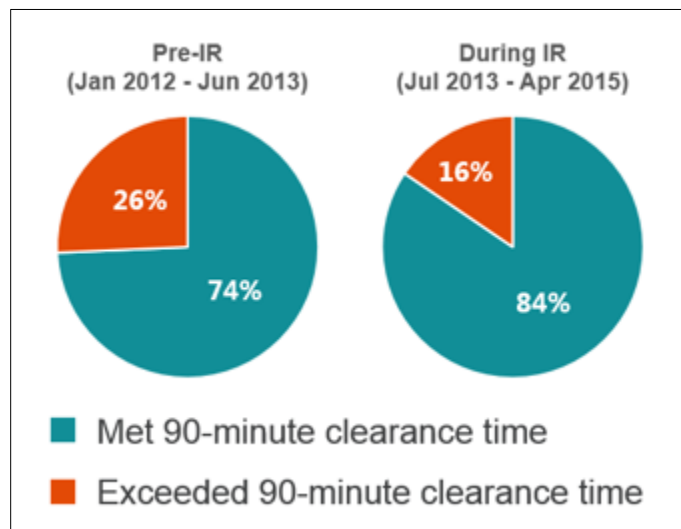

Figure 24. District 8 Pilot – 90-Minute Clearance Time Performance

### Benefits of TIM Performance Measurement

ODOT is working to update the Statewide TIM Strategic Plan and to create a Transportation Systems Management and Operations Performance Measurement Plan. The FHWA is funding the update to the Strategic Plan, and there are many stakeholders involved. ODOT believes that, through these efforts, the TIM program will take a giant step forward and performance measurement and management will be better organized and prioritized in the coming years.

In addition, ODOT District 8 has found significant positive impacts of the Dedicated Incident Response pilot project; as a result, the dedicated incident responder is now a permanent position in District 8.

---

ODOT district staff plan to demonstrate the value of these positions to other district-level managers, as well as to the state legislature, to justify more of these positions throughout the state.

---

## Kentucky TIM Performance Measurement Case Study

### Overview of TIM Program

The Kentucky Transportation Cabinet (KTC) operates three regional traffic management centers (TMCs) – ARTIMIS in Cincinnati/Northern Kentucky, TRIMARC in Louisville, and Crosstown Traffic in Lexington. Statewide traffic incident management (TIM) in Kentucky is coordinated by the Incident Management Task Force (IMTF), which was established by the Governor’s Executive Committee on Highway Safety. This task force consists of professionals from the KTC and various other agencies throughout Kentucky. There is a memorandum of agreement (MOA) among all of these agencies to share data related to incident management.

The KTC also operates the Safety Assistance for Freeway Emergencies (SAFE) Patrol on major interstate highways and parkways across the state. SAFE operates seven days a week from 6:00 a.m. to 10:00 p.m.<sup>12</sup> TRIMARC operates its own FSP during business hours, Monday through Friday, 6:30 a.m. to 6:30 p.m., which corresponds with TRIMARC’s hours of operation.<sup>13</sup> SAFE and FSP drivers are dispatched by the TMCs. The drivers collect and document incident-related data through a proprietary software system, but they can also report urgent updates directly to the TMC operators or through the 511 system.

The KTC also has a program known as “Notify Every Truck,” which is aimed at helping commercial vehicle operations avoid major incident queues. Drivers registered for the program receive email and text alerts for incidents anticipated to last more than two hours in an attempt to help them adjust their routes and stops as much as possible.

### Data Collection and Management

TMC operators monitor and track incidents as they are detected by TMC operators or called in by the FSP drivers or other sources. Although the database used by the FSP is not common statewide, the same proprietary software is used in both the Louisville and Frankfurt regions. The FSP and TMC operators also use separate data systems, which sometimes results in duplication of incident reports; however, the KTC plans to move to a single statewide database in 2016.

The KTC has multiple data-sharing agreements and provides the incident report data to 14 different organizations. The KTC has an agreement with INRIX and recently entered into an agreement with Waze, who is now mining the data.

Kentucky collects data on the three national TIM performance measures via the state crash report. Using the crash report, police officers can record the “time notified,” “time arrived,” and “roadway opened.”<sup>14</sup> When an officer leaves an incident scene, he/she clears the incident from the CAD system, and this is the time that is recorded in the system as the incident clearance time. However, because law

---

<sup>12</sup> Kentucky Transportation Cabinet, Safe Patrol, <http://transportation.ky.gov/Incident-Management/Pages/Safe-Patrol.aspx>, accessed March 4, 2016.

<sup>13</sup> TRIMARC, Freeway Service Patrol, [http://www.trimarc.org/site/pages/Freeway\\_Service\\_Patrol.php](http://www.trimarc.org/site/pages/Freeway_Service_Patrol.php), accessed March 4, 2016.

<sup>14</sup> Commonwealth of Kentucky, Kentucky Uniform Police Traffic Collision Report, [http://www.actar.org/pdf/ky\\_rep1.pdf](http://www.actar.org/pdf/ky_rep1.pdf), accessed March 22, 2016.



---

enforcement is not always the last to leave the scene of an incident, this can lead to inaccurate data on incident clearance times. In addition, the IMTF wanted to track secondary crashes more carefully. Through a police officer that was a member of both the IMTF and the state Traffic Records Coordinating Committee (TRCC), the two groups worked to add a supplemental code for “Secondary Collision” to the Kentucky Uniform Police Traffic Collision Report form in 2007.<sup>15</sup>

### Performance Analysis and Reporting

The KTC participates in the Federal Highway Administration’s annual TIM Self-Assessment, but does not produce any other official performance reports. The KTC does, however, hold quarterly incident management meetings with first responders in each district, and the incident performance data is used for discussion at these meetings.

The KTC has developed a process for calculating the cost of roadway closures caused by traffic incidents in Louisville. It is a local process, built in Excel, which takes in many different factors, including the average number of people per vehicle, total cost of commuters per hour, percent of trucks and cars on the roadway, average length of vehicles, spacing, and annual average daily traffic (AADT). The data comes from a variety of sources, including the national travel survey, local air pollution control, and Google. The process considers all the various ways there are to bypass an incident scene. The base savings is then determined using the length of the queue. The actual queue length is then compared to the calculated queue length. This information is shared with the KTC after the analysis is completed and is included in the monthly report to be discussed at the quarterly freeway incident management meetings.

---

<sup>15</sup> Pigman, J. G., E. R. Green, and J. R. Walton, Identification of Secondary Crashes and Recommended Countermeasures, Kentucky Transportation Cabinet, 2011, [http://www.ktc.uky.edu/files/2012/06/KTC\\_11\\_06\\_SPR\\_402\\_10\\_1F.pdf](http://www.ktc.uky.edu/files/2012/06/KTC_11_06_SPR_402_10_1F.pdf).

---

## Missouri TIM Performance Measurement Case Study

### Overview of TIM Program

The Missouri Department of Transportation (MoDOT) operates traffic management centers (TMCs) in St. Louis and Springfield. In addition, MoDOT jointly operates the Kansas City Scout (KC Scout) TMC in Kansas City with the Kansas Department of Transportation (KDOT).

The St. Louis TMC is home to the Gateway Guide Intelligent Transportation Systems (ITS) program. Gateway Guide uses real-time traffic information from ITS infrastructure throughout the region to improve safety and mobility in the St. Louis region.<sup>16</sup> The Gateway Guide program also includes a Motorist Assist and Emergency Response team that has been in operation since 1993 and covers over 160 center lane miles in the St. Louis region. The Motorist Assist operators, 12 per shift, patrol all major interstates and highways in the region Sunday to Sunday (excluding major holidays) from 5:00 am to 7:30 pm, searching for lane obstructions and drivers in need of help. There are signs posted along the roadways to inform drivers that they are on a route covered by this program. During the off hours, when there are no Motorist Assist operations, MoDOT operates an Emergency Response crew that helps with major obstructions.<sup>17</sup>

KC Scout manages more than 125 miles of roadways in the region. MoDOT and KDOT work together, coordinating among many responder agencies at both the state and local levels. The advanced traffic management system (ATMS) used in Kansas City was state-of-the-art when it was implemented in 2011, integrating weather information with all other information coming from the regional ITS infrastructure.<sup>18</sup> The Motorist Assist program in Kansas City operates Monday through Friday from 5:00 a.m. to 7:30 p.m. In both regions, MoDOT estimates a 20-minute wait time for a Motorist Assist operator to arrive, even without calling for help.<sup>19</sup>

There are also TIM working groups that allow MoDOT to work with law enforcement and other partners to share and discuss the incident management performance measures. The Kansas City TIM group meets on a quarterly basis; the St. Louis group meets less frequently but is gaining momentum. There is also a TIM Strategic Highway Safety Plan (SHSP) executive subcommittee that is working to elevate TIM statewide. The goals of this subcommittee are to provide better rural coverage by delivering the National TIM Responder Training to all responder agencies, including but not limited to public works, law enforcement, fire/rescue, emergency medical service, and towing and recovery.<sup>20</sup>

---

<sup>16</sup> Missouri DOT. About MoDOT's Gateway Guide website, <http://www.gatewayguide.com/about-gateway-guide.html>, accessed March 3, 2016.

<sup>17</sup> Missouri DOT, Gateway Guide's Motorist Assist and Emergency Response Program website, <http://www.modot.org/stlouis/links/motoristassist.htm>, accessed March 3, 2016.

<sup>18</sup> Kansas City Scout, Managing Freeway Incidents website, <http://www.kcscout.com/TIM.aspx>, accessed March 3, 2016.

<sup>19</sup> Missouri DOT, Kansas City Motorist Assist website, <http://www.modot.org/kansascity/programs/motoristassist.htm>, accessed March 3, 2016.

<sup>20</sup> Missouri DOT, National TIM Responder Training Program website, <http://www.modot.org/safety/TIMTraining.htm>, accessed March 3, 2016.

---

## Data Collection and Management

The TMC operators in Missouri use closed circuit television (CCTV) cameras as well as calls from Motorist Assist operators and other responder agencies to locate incidents on the highways. TMC operators track any incident identified, regardless of how minor the incident is. As part of the TIM working group agreements with law enforcement and other partners, MoDOT receives law enforcement crash report data and shares performance data and findings. In 2012, when the Missouri crash report was being updated, MoDOT had a series of conversations with the Missouri State Highway Patrol (MSHP) to communicate the importance of tracking and reporting performance measures more effectively statewide. The Missouri crash report form was updated to give law enforcement more options to provide details, including whether there is another incident or recurring congestion ahead of a crash.

There is also an internal text alert system set up for MoDOT staff and their partners to help increase awareness of incidents that occur where MoDOT does not have ITS devices. While the process of manually inputting information from the field into the ATMS software is labor intensive, it increases the number of incidents that MoDOT is able to track. MoDOT hopes to make strides towards automating this process in the future.

Both roadway clearance time (RCT) and incident clearance time (ICT) are collected and recorded at each TMC through the ATMS. The TMC incident reports are tagged with a location and are time stamped, both when the TMC operators receive notice of an incident and when they receive updates throughout the duration of an incident (including roadway and incident clearance times).

In general, MoDOT does not initiate data collection on secondary crashes; however, TMC operators will track and report secondary crashes if they are identified as such by law enforcement. In KC Scout's ATMS, TMC operators can note if a crash is identified as secondary in nature.

One of MoDOT's challenges with data collection is having to coordinate with so many different law enforcement agencies. While law enforcement is present at all major incidents, there are hundreds of different local/regional law enforcement agencies in the state. There are 134 municipalities in the St. Louis region alone, most of which are not patrolled by the MSHP, even on the interstate highways. Working with these agencies to explain the processes of what data needs to be collected and why it is important has been a big undertaking. Some progress was made when revising the crash report in 2012 to include secondary crashes, but there is still progress to be made towards getting everyone on the same page with recording roadway and incident clearance times.

## Performance Analysis and Reporting

MoDOT produces a "Tracker" report for measures of departmental performance throughout the state. The Tracker report is presented to and discussed with executive management on a quarterly basis. Among other performance measures, MoDOT reports the national TIM performance measures, RCT and ICT, for those incidents of which they are aware statewide. As was previously described, secondary crashes are also tracked and reported, but only when law enforcement either marks it on the crash report or notifies the TMC operators. Figure 25 and Figure 26 were extracted from the 3<sup>rd</sup> quarter 2015 Tracker report. These figures show the average ICT as compared to previous quarters/years in St. Louis and Kansas City, respectively.<sup>21</sup>

---

<sup>21</sup> Gough, P. (District Engineer), Tracker: Measures of Departmental Performance – Operate a Reliable and Convenient Transportation System, Missouri DOT, <http://www.modot.org/about/documents/Chapter5.pdf>.

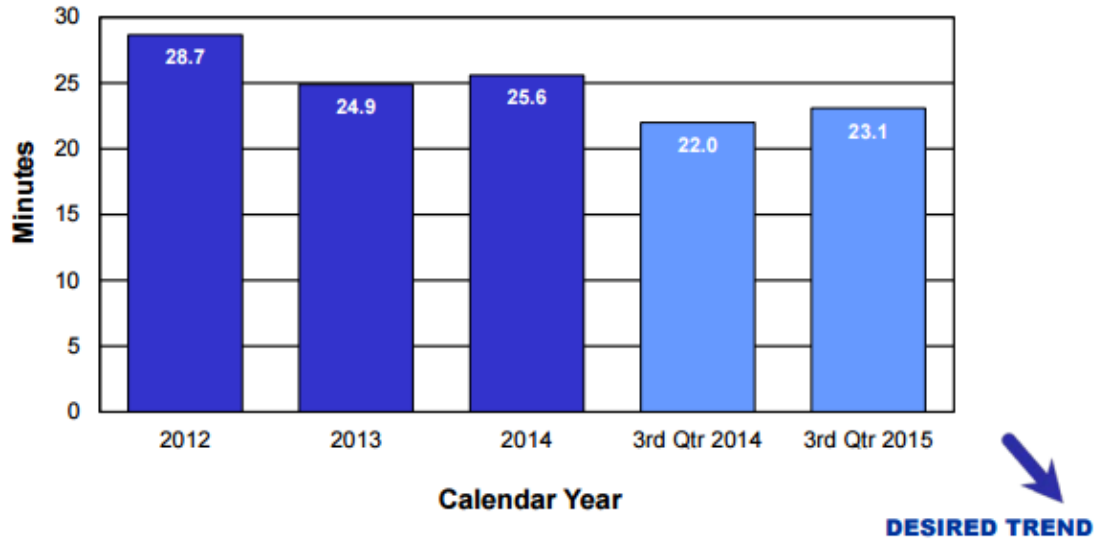

Figure 25. Average Time to Clear Traffic Incident – St. Louis

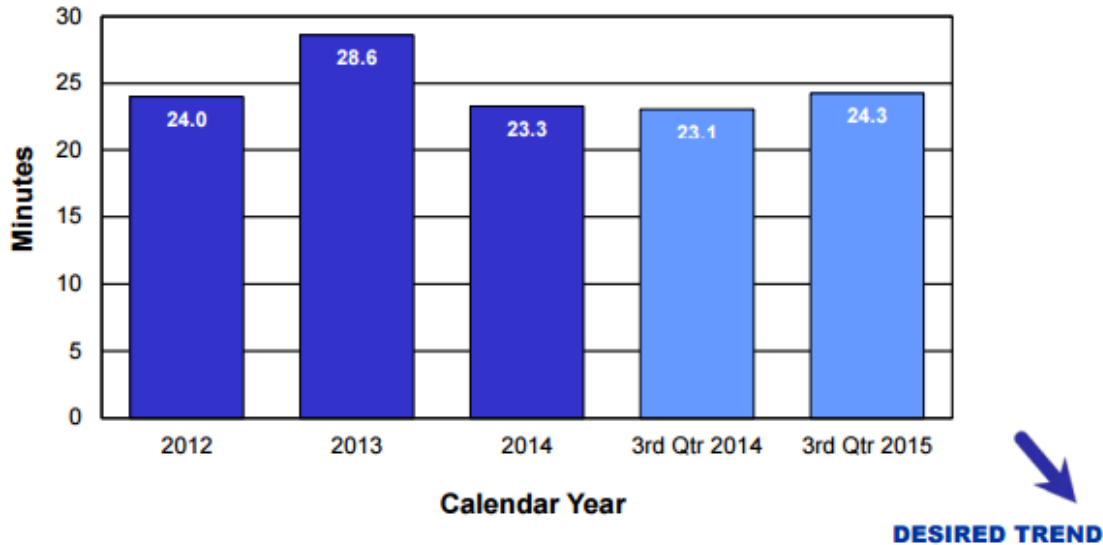

Figure 26. Average Time to Clear Traffic Incident – Kansas City

KC Scout also produces detailed monthly and annual reports. The primary source of data for these reports is the ATMS. On a monthly basis, KC Scout reports the numbers of total incidents, lane blocking incidents, and multi-vehicle incidents; the total minutes of blocked lanes; the average time to clear lanes; the total emergency response service rendered throughout the month; and overall mobility data for the region. The report presents the data compared to the previous months of the year and by day of week, time of day, incident type, severity level, and location. It also includes a summary of all notable roadwork projects that occurred throughout the region during that month.<sup>22</sup> The annual report shows similar data that is aggregated and analyzed over the course of the entire year. Figure 27 was extracted

<sup>22</sup> KC Scout, Monthly Reports website, <http://www.kcscout.com/ReportsMonthly.aspx>, accessed March 3, 2016.

from the 2014 annual report. This graph shows the number of incidents and average RCT by time of day.<sup>23</sup>

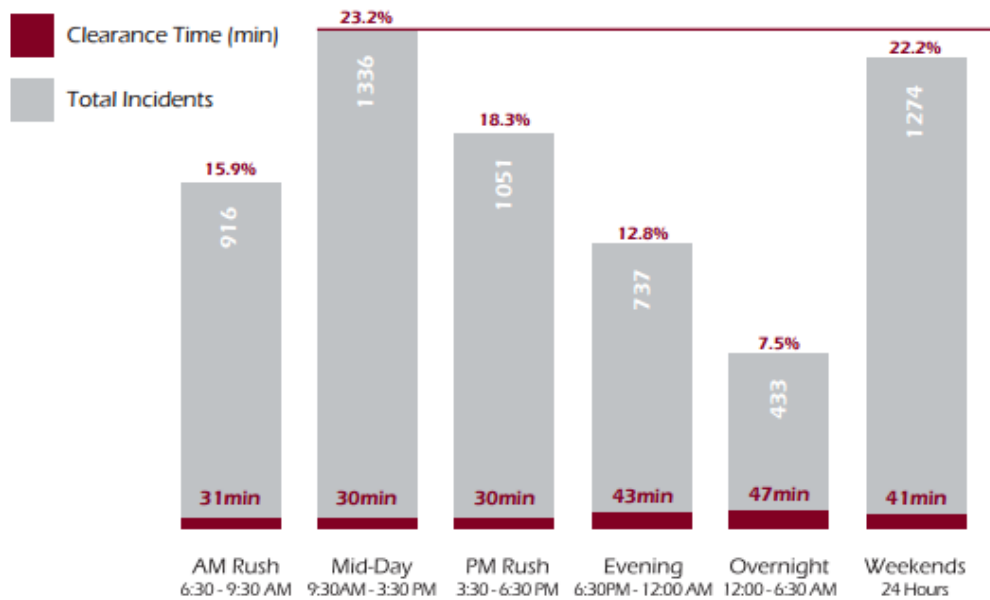

Figure 27. Number of Incidents and Average Time to Clear Lanes by Time of Day (2014)

### Benefits of TIM Performance Measurement

According to the KC Scout 2014 Annual Report, for every \$1 spent by the program, it provides approximately \$8 in benefits. Since the TIM program in Kansas City was developed into a robust program in 2007, there has been a 30% reduction in ICTs throughout the region. Quicker clearance times have resulted in reduced congestion and travel times, resulting in a financial benefit of fuel savings and an environmental benefit of cleaner air from reduced emissions. A reduction in secondary crashes since the program began has resulted in a savings in other operation costs.<sup>24,25</sup>

Having data to measure TIM performance has helped raise awareness of the importance of TIM in Missouri. The increased awareness has led to the development of a team to examine how TIM processes can be improved in both rural and urban areas throughout the state. In recent years, meeting with executive leadership on a quarterly basis to discuss TIM performance has helped to maintain momentum and to make improvements at the agency level. The heightened awareness of the importance of TIM has also led to many high-level meetings with law enforcement to set processes and procedures intended to help the TIM partners in Missouri operate as efficiently as possible.

<sup>23</sup> Kansas and Missouri DOTs, Kansas City Scout 2014 Annual Report, <http://www.kcscout.com/downloads/Reports/Annual/AnnualReport2014.pdf>.

<sup>24</sup> Kansas and Missouri DOTs, Kansas City Scout 2014 Annual Report, <http://www.kcscout.com/downloads/Reports/Annual/AnnualReport2014.pdf>.

<sup>25</sup> KC Scout, Emergency Response Operations website, <http://www.kcscout.com/MotoristAssist.aspx>, accessed March 4, 2016.

## APPENDIX C – CHECKLIST OF TIM DATA ELEMENTS BY SOURCE

Data Elements	Data Sources							
	Transportation				Public Safety			
	from TMC/TOC		from Field Personnel (FSP, IR team)		from Crash Report		from CAD/Other	
	Yes	No	Yes	No	Yes	No	Yes	No
<b>Required for 3 National TIM PMs</b>								
Time of first recordable awareness of an incident by a responsible agency	<input type="checkbox"/>	<input type="checkbox"/>	<input type="checkbox"/>	<input type="checkbox"/>	<input type="checkbox"/>	<input type="checkbox"/>	<input type="checkbox"/>	<input type="checkbox"/>
Time of first confirmation that all lanes are available for traffic flow	<input type="checkbox"/>	<input type="checkbox"/>	<input type="checkbox"/>	<input type="checkbox"/>	<input type="checkbox"/>	<input type="checkbox"/>	<input type="checkbox"/>	<input type="checkbox"/>
Time last responder has left scene	<input type="checkbox"/>	<input type="checkbox"/>	<input type="checkbox"/>	<input type="checkbox"/>	<input type="checkbox"/>	<input type="checkbox"/>	<input type="checkbox"/>	<input type="checkbox"/>
Whether a crash is secondary to a primary crash/incident	<input type="checkbox"/>	<input type="checkbox"/>	<input type="checkbox"/>	<input type="checkbox"/>	<input type="checkbox"/>	<input type="checkbox"/>	<input type="checkbox"/>	<input type="checkbox"/>
<b>Desirable for other TIM PMs</b>								
Time incident verified	<input type="checkbox"/>	<input type="checkbox"/>	<input type="checkbox"/>	<input type="checkbox"/>	<input type="checkbox"/>	<input type="checkbox"/>	<input type="checkbox"/>	<input type="checkbox"/>
Time response identified	<input type="checkbox"/>	<input type="checkbox"/>	<input type="checkbox"/>	<input type="checkbox"/>	<input type="checkbox"/>	<input type="checkbox"/>	<input type="checkbox"/>	<input type="checkbox"/>
Time response dispatched	<input type="checkbox"/>	<input type="checkbox"/>	<input type="checkbox"/>	<input type="checkbox"/>	<input type="checkbox"/>	<input type="checkbox"/>	<input type="checkbox"/>	<input type="checkbox"/>
Time first response arrives on scene	<input type="checkbox"/>	<input type="checkbox"/>	<input type="checkbox"/>	<input type="checkbox"/>	<input type="checkbox"/>	<input type="checkbox"/>	<input type="checkbox"/>	<input type="checkbox"/>
Time normal traffic flow returns	<input type="checkbox"/>	<input type="checkbox"/>	<input type="checkbox"/>	<input type="checkbox"/>	<input type="checkbox"/>	<input type="checkbox"/>	<input type="checkbox"/>	<input type="checkbox"/>
<b>Desirable for TIM Performance Analysis</b>								
<i>Details of Incident</i>								
Date of Incident	<input type="checkbox"/>	<input type="checkbox"/>	<input type="checkbox"/>	<input type="checkbox"/>	<input type="checkbox"/>	<input type="checkbox"/>	<input type="checkbox"/>	<input type="checkbox"/>
Time incident occurred	<input type="checkbox"/>	<input type="checkbox"/>	<input type="checkbox"/>	<input type="checkbox"/>	<input type="checkbox"/>	<input type="checkbox"/>	<input type="checkbox"/>	<input type="checkbox"/>
Description of Incident	<input type="checkbox"/>	<input type="checkbox"/>	<input type="checkbox"/>	<input type="checkbox"/>	<input type="checkbox"/>	<input type="checkbox"/>	<input type="checkbox"/>	<input type="checkbox"/>
Incident type	<input type="checkbox"/>	<input type="checkbox"/>	<input type="checkbox"/>	<input type="checkbox"/>	<input type="checkbox"/>	<input type="checkbox"/>	<input type="checkbox"/>	<input type="checkbox"/>
Severity of incident (e.g., minor, major)	<input type="checkbox"/>	<input type="checkbox"/>	<input type="checkbox"/>	<input type="checkbox"/>	<input type="checkbox"/>	<input type="checkbox"/>	<input type="checkbox"/>	<input type="checkbox"/>
Severity of injury (e.g., none, minor, fatality)	<input type="checkbox"/>	<input type="checkbox"/>	<input type="checkbox"/>	<input type="checkbox"/>	<input type="checkbox"/>	<input type="checkbox"/>	<input type="checkbox"/>	<input type="checkbox"/>
<i>Conditions at Time of Incident</i>								
Weather conditions	<input type="checkbox"/>	<input type="checkbox"/>	<input type="checkbox"/>	<input type="checkbox"/>	<input type="checkbox"/>	<input type="checkbox"/>	<input type="checkbox"/>	<input type="checkbox"/>
Lighting conditions	<input type="checkbox"/>	<input type="checkbox"/>	<input type="checkbox"/>	<input type="checkbox"/>	<input type="checkbox"/>	<input type="checkbox"/>	<input type="checkbox"/>	<input type="checkbox"/>
<i>Roadway</i>								
Roadway name	<input type="checkbox"/>	<input type="checkbox"/>	<input type="checkbox"/>	<input type="checkbox"/>	<input type="checkbox"/>	<input type="checkbox"/>	<input type="checkbox"/>	<input type="checkbox"/>
Roadway type (e.g., freeway, arterial)	<input type="checkbox"/>	<input type="checkbox"/>	<input type="checkbox"/>	<input type="checkbox"/>	<input type="checkbox"/>	<input type="checkbox"/>	<input type="checkbox"/>	<input type="checkbox"/>
Roadway direction	<input type="checkbox"/>	<input type="checkbox"/>	<input type="checkbox"/>	<input type="checkbox"/>	<input type="checkbox"/>	<input type="checkbox"/>	<input type="checkbox"/>	<input type="checkbox"/>
Roadway location (e.g., lat/long, milepost)	<input type="checkbox"/>	<input type="checkbox"/>	<input type="checkbox"/>	<input type="checkbox"/>	<input type="checkbox"/>	<input type="checkbox"/>	<input type="checkbox"/>	<input type="checkbox"/>
Surface condition	<input type="checkbox"/>	<input type="checkbox"/>	<input type="checkbox"/>	<input type="checkbox"/>	<input type="checkbox"/>	<input type="checkbox"/>	<input type="checkbox"/>	<input type="checkbox"/>
Work zone	<input type="checkbox"/>	<input type="checkbox"/>	<input type="checkbox"/>	<input type="checkbox"/>	<input type="checkbox"/>	<input type="checkbox"/>	<input type="checkbox"/>	<input type="checkbox"/>
<i>Lanes Involved in Incident</i>								
Number of lanes involved	<input type="checkbox"/>	<input type="checkbox"/>	<input type="checkbox"/>	<input type="checkbox"/>	<input type="checkbox"/>	<input type="checkbox"/>	<input type="checkbox"/>	<input type="checkbox"/>

Total roadway lanes at scene	<input type="checkbox"/>	<input type="checkbox"/>	<input type="checkbox"/>	<input type="checkbox"/>	<input type="checkbox"/>	<input type="checkbox"/>	<input type="checkbox"/>	<input type="checkbox"/>
Time of closing/opening of each lane involved	<input type="checkbox"/>	<input type="checkbox"/>	<input type="checkbox"/>	<input type="checkbox"/>	<input type="checkbox"/>	<input type="checkbox"/>	<input type="checkbox"/>	<input type="checkbox"/>
<i>Vehicles Involved in Incident</i>								
Number of vehicles involved	<input type="checkbox"/>	<input type="checkbox"/>	<input type="checkbox"/>	<input type="checkbox"/>	<input type="checkbox"/>	<input type="checkbox"/>	<input type="checkbox"/>	<input type="checkbox"/>
Hazmat vehicle	<input type="checkbox"/>	<input type="checkbox"/>	<input type="checkbox"/>	<input type="checkbox"/>	<input type="checkbox"/>	<input type="checkbox"/>	<input type="checkbox"/>	<input type="checkbox"/>
Heavy vehicle involved	<input type="checkbox"/>	<input type="checkbox"/>	<input type="checkbox"/>	<input type="checkbox"/>	<input type="checkbox"/>	<input type="checkbox"/>	<input type="checkbox"/>	<input type="checkbox"/>
<i>Participants Involved in Incident</i>								
Number of participants involved	<input type="checkbox"/>	<input type="checkbox"/>	<input type="checkbox"/>	<input type="checkbox"/>	<input type="checkbox"/>	<input type="checkbox"/>	<input type="checkbox"/>	<input type="checkbox"/>
Injury involved	<input type="checkbox"/>	<input type="checkbox"/>	<input type="checkbox"/>	<input type="checkbox"/>	<input type="checkbox"/>	<input type="checkbox"/>	<input type="checkbox"/>	<input type="checkbox"/>
Number of Injuries	<input type="checkbox"/>	<input type="checkbox"/>	<input type="checkbox"/>	<input type="checkbox"/>	<input type="checkbox"/>	<input type="checkbox"/>	<input type="checkbox"/>	<input type="checkbox"/>
Injury type	<input type="checkbox"/>	<input type="checkbox"/>	<input type="checkbox"/>	<input type="checkbox"/>	<input type="checkbox"/>	<input type="checkbox"/>	<input type="checkbox"/>	<input type="checkbox"/>
Participant types	<input type="checkbox"/>	<input type="checkbox"/>	<input type="checkbox"/>	<input type="checkbox"/>	<input type="checkbox"/>	<input type="checkbox"/>	<input type="checkbox"/>	<input type="checkbox"/>
<i>Emergency Responders and Vehicles</i>								
Number of responders involved	<input type="checkbox"/>	<input type="checkbox"/>	<input type="checkbox"/>	<input type="checkbox"/>	<input type="checkbox"/>	<input type="checkbox"/>	<input type="checkbox"/>	<input type="checkbox"/>
Response organization	<input type="checkbox"/>	<input type="checkbox"/>	<input type="checkbox"/>	<input type="checkbox"/>	<input type="checkbox"/>	<input type="checkbox"/>	<input type="checkbox"/>	<input type="checkbox"/>
Responder(s) ID	<input type="checkbox"/>	<input type="checkbox"/>	<input type="checkbox"/>	<input type="checkbox"/>	<input type="checkbox"/>	<input type="checkbox"/>	<input type="checkbox"/>	<input type="checkbox"/>
Response vehicle(s) type	<input type="checkbox"/>	<input type="checkbox"/>	<input type="checkbox"/>	<input type="checkbox"/>	<input type="checkbox"/>	<input type="checkbox"/>	<input type="checkbox"/>	<input type="checkbox"/>
Response vehicle(s) arrival on scene	<input type="checkbox"/>	<input type="checkbox"/>	<input type="checkbox"/>	<input type="checkbox"/>	<input type="checkbox"/>	<input type="checkbox"/>	<input type="checkbox"/>	<input type="checkbox"/>
Response vehicle(s) departure from scene	<input type="checkbox"/>	<input type="checkbox"/>	<input type="checkbox"/>	<input type="checkbox"/>	<input type="checkbox"/>	<input type="checkbox"/>	<input type="checkbox"/>	<input type="checkbox"/>



Nevada Department of Transportation  
Rudy Malfabon, P.E. Director  
Ken Chambers, Research Division Chief  
(775) 888-7220  
kchambers@dot.nv.gov  
1263 South Stewart Street  
Carson City, Nevada 89712